

# AIRTECH<sup>®</sup>

Molle ad aria

04/05

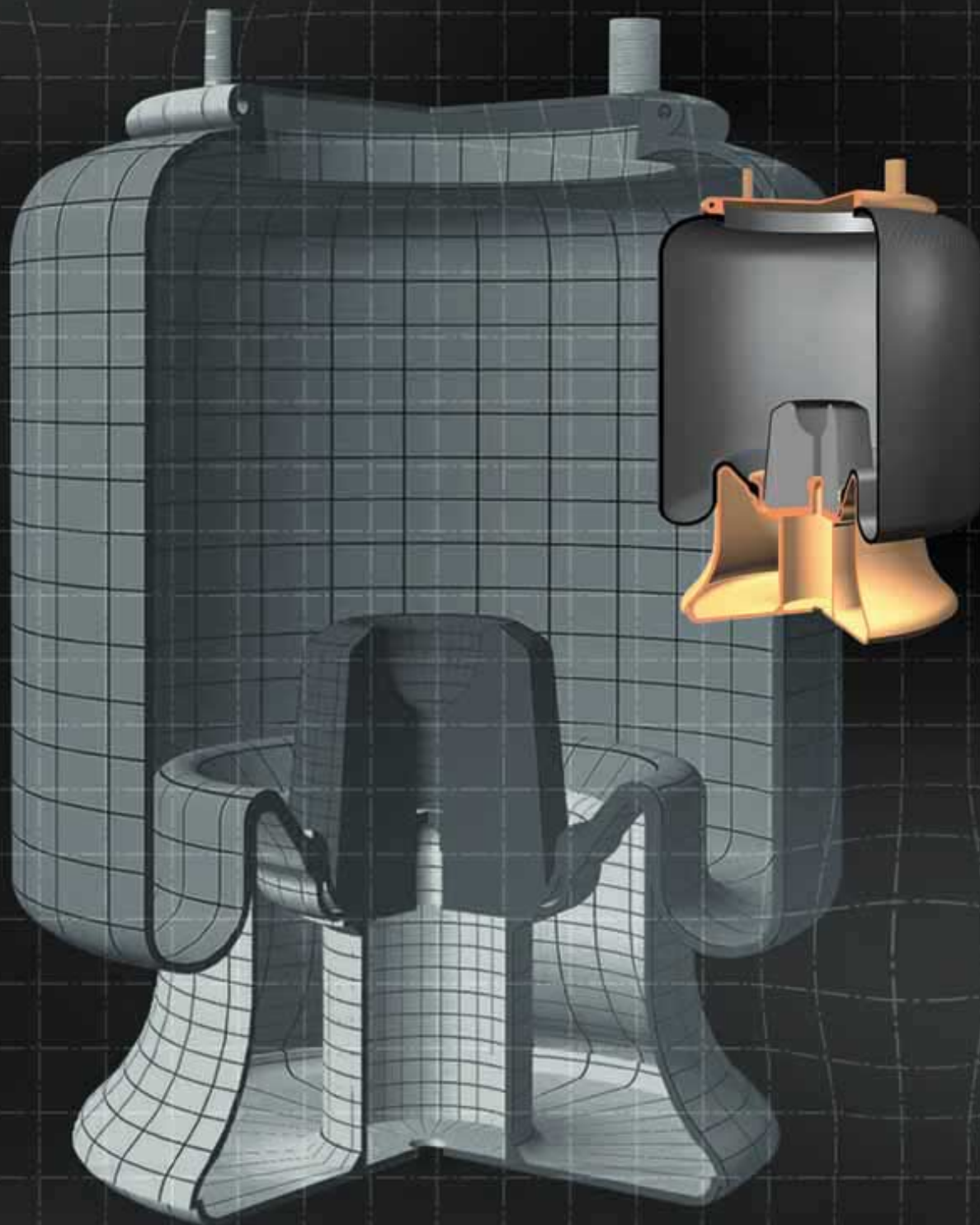





<b>INTRODUZIONE</b>	<b>1</b>
<b>LISTA APPLICAZIONI</b>	<b>7</b>
<b>MEMBRANE</b>	<b>29</b>
<b>MOLLE AD ARIA COMPLETE</b>	<b>85</b>
<b>MOLLE AD ARIA A LOBI</b>	<b>261</b>
<b>MOLLE AD ARIA PER SEDILI</b>	<b>279</b>
<b>LISTA CORRISPONDENZE</b>	<b>287</b>
da codice <b>PIRELLI</b>	<b>288</b>
da codice <b>RNB</b>	<b>296</b>
da codice <b>AIRTECH</b>	<b>304</b>
<b>MOLLE AD ARIA A LOBI</b>	<b>312</b>
<b>MOLLE AD ARIA PER SEDILI</b>	<b>314</b>
<b>CONDIZIONI GENERALE DI VENDITA</b>	<b>317</b>
<b>MODULO RICHIESTA SPECIALE</b>	<b>319</b>





Il gruppo Aktas, che comprende Aktas Air Suspension Systems, Akkaucuk Ltd. Co., SKS Wiper Tool, Aklar Automotive e LFT Luftfedertechnik Germany, è formato da una serie di aziende moderne ed efficienti che assicurano la produzione completa di tutti i componenti necessari per la produzione delle molle ad aria.

La Aktas ha raggiunto già nel primo anno 1999 un fatturato pari a 21 milioni DM, e punta al proprio rinnovamento con nuovi e costanti investimenti. Il gruppo, sulla scia degli standard mondiali, ha adottato "la qualità totale" quale principale filosofia di gestione.

La Aktas cerca continuamente di accrescere la propria quota di mercato costruendo nuovi prodotti di elevata qualità, per rispondere alle aspettative dei clienti. A questo proposito, vengono incessantemente sviluppati studi incentrati sulle necessità della clientela, come l'immagazzinamento dei dati e delle informazioni, la qualità basata sulla prevenzione, l'annullamento dei difetti e la costituzione e lo sviluppo di un sistema di certificazione qualità, responsabilizzando direttamente il management e le maestranze.

In Aktas sono largamente usate le analisi FMEA (Failure Mode Effect Analysis), le analisi di Pareto, il diagramma causa-effetti, il metodo 8D, e i procedimenti di controllo statistico sulla potenzialità dei macchinari e del processo.

La Aktas offre una garanzia completa sui propri prodotti e una assicurazione di responsabilità contro le terze parti.

La Aktas, anche se consapevole del livello qualitativo raggiunto, tenderà nella ricerca del continuo miglioramento dei propri prodotti.



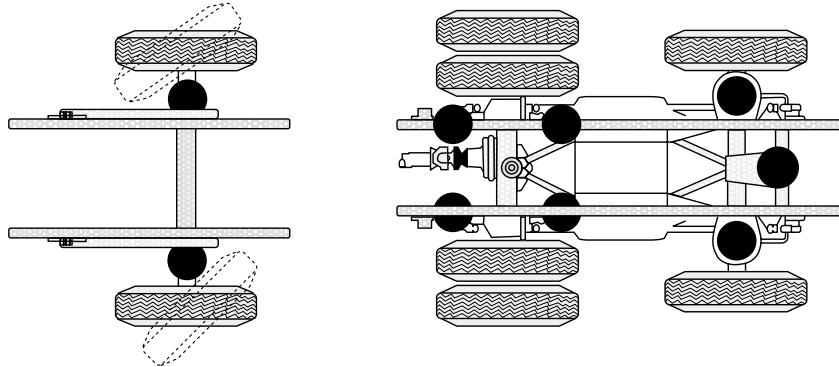

## 1. Autocarri

Gli autocarri dell'ultima generazione, in particolare veicoli porta container e veicoli intermodali, sono equipaggiati con successo con molle ad aria. E' possibile usare le sospensioni pneumatiche sull'assale anteriore, posteriore o sul terzo asse, così come sugli assali dei semirimorchi. A parte la naturale morbidezza del molleggio che protegge il veicolo, il carico e la strada, le molle ad aria offrono anche la possibilità di sollevare e abbassare il veicolo per agevolare le operazioni di carico e scarico delle merci.

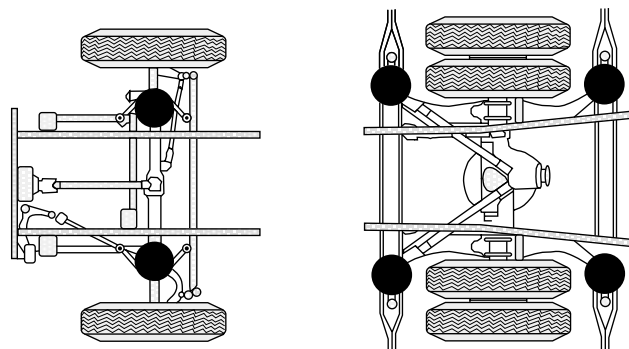

## 2. Autobus

Molti sono i vantaggi che offrono le molle ad aria sugli autobus, quali il raggiungimento di un notevole livello di comfort durante la marcia e la possibilità di mantenere altezze costanti a prescindere dal carico.

Ciò generalmente richiede due molle ad aria montate sull'asse anteriore e quattro su quello posteriore. In Europa occidentale e negli Stati Uniti tutti gli autobus sono equipaggiati con molle ad aria.

In tutti gli altri paesi l'utilizzo delle sospensioni pneumatiche sui veicoli si sta incrementando di anno in anno.



Le sospensioni pneumatiche sono studiate in base a specifiche condizioni, come le capacità di carico, le caratteristiche del braccio della sospensione e della sua flessione. Per i veicoli industriali viene fatta una distinzione tra due tipi base di sospensione pneumatica, vale a dire molle ad aria a membrana e molle ad aria a soffietto.

### **Molle ad aria a membrana con fissaggio conico tipo “tubeless”**

Le molle ad aria a membrana hanno una naturale morbidezza del molleggio e un elevato grado di flessibilità laterale. Inoltre, permettono un’ampia possibilità di abbassamento e innalzamento variando semplicemente l’altezza, senza dover cambiare il diametro. Questo permette al veicolo, soprattutto nel caso di autocarri e rimorchi, di alzarsi e abbassarsi con l’ausilio della molla ad aria usata come sospensione sull’asse, senza ulteriori equipaggiamenti. Le molle ad aria a membrana sono facili da montare e fissare. Il fissaggio conico va ad incastrarsi negli incavi della piastra superiore tramite pressione interna, in modo simile alle gomme “tubeless”. In questo tipo di fissaggio le piastre possono essere riutilizzate quando si sostituiscono le membrane.



### **Molle ad aria a membrana con fissaggio grimpato**

Le molle ad aria a membrana con fissaggio grimpato si differenziano da quelle tipo “tubeless” nel metodo di assemblaggio. La resistente grimpatura tra la membrana e le parti metalliche, evita che la molla si distacchi sotto sollecitazioni estreme. Le molle ad aria a membrana di questo tipo vengono fornite dalla Aktas anche complete; vale a dire che membrana, attacco superiore, paracolpo interno e pistone, dove necessario, sono assemblati in un unico pezzo.

### **Molle ad aria a soffietto**

La caratteristica principale delle molle ad aria a soffietto è che la loro particolare struttura e conformazione permette di ottenere un’elevata corsa con un’altezza ridotta della molla. Alle estremità vengono inserite, tramite vulcanizzazione, delle anime circolari che servono a fissare gli anelli metallici necessari per il montaggio sul veicolo.



# DISEGNO DEL PRODOTTO

## MEMBRANA

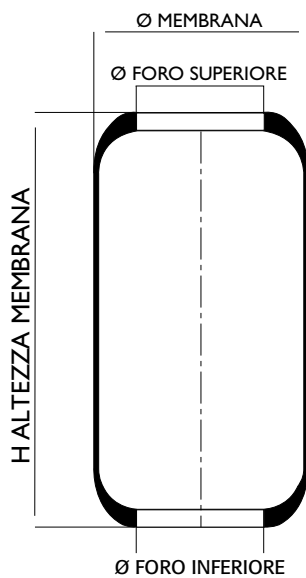

## MOLLA AD ARIA

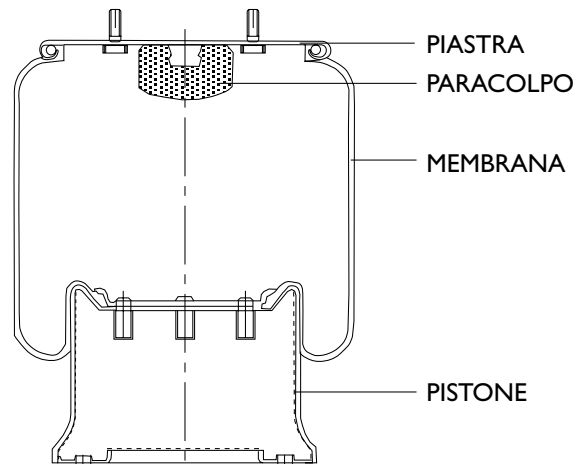

1. La piastra superiore può essere di tipo conico o grimpata. Questa fissa la membrana al telaio del veicolo.
2. Il paracolpo impedisce il tamponamento di fine corsa.
3. La membrana è costruita utilizzando materiali con particolari caratteristiche di elasticità. Generalmente costituiti da uno strato esterno, di almeno due tele rinforzate, e di uno strato interno.
4. Il pistone serve a mantenere la molla sull'asse. E' fatto preferibilmente d'acciaio, d'alluminio o materiali compositi. Quando la molla si flette, si schiaccia e fa scorrere la membrana sul pistone.

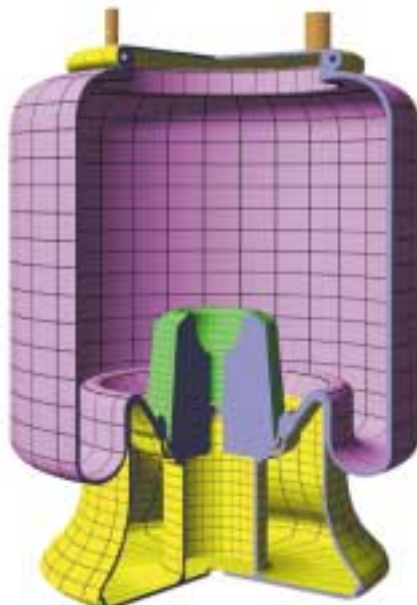



# LISTA APPLICAZIONI





# LISTA APPLICAZIONI



Costruttore	Rif. ORIGINALE	Rif. RNB	Rif. AIRTECH	Tipo	Pag.
<b>ACERBI</b>					
		A520019C	391304 K	molla completa di pistone	252
<b>AUSTERAS</b>					
	99381009	A520149C	361420 K	molla completa di pistone	238
	99381010	A520148C	361480 K	molla completa di pistone	240
<b>AUWARTER</b>					
	B 510040	A520122	3701	membrana	35
		A520002	3644	membrana	31
<b>BARTOLETTI</b>					
	91619005	A520070C	3813 K	molla completa di pistone	107
	91619011	A520021C	391318 K	molla completa di pistone	255
<b>BATTAGLINO</b>					
	0.41.03.003.0	A520169C	3813-03 K	molla completa di pistone	110
	0.41.03.007.0	A520168C	391210-01 K	molla completa di pistone	250
	2211400	A520070C	3813 K	molla completa di pistone	107
	2211401	A520021C	391318 K	molla completa di pistone	255
	2211900	A520167C	362421 K	molla completa di pistone	242
	2211907	A520144C	361421 K	molla completa di pistone	239
	41040010	A520142C	382430 K	molla completa di pistone	244
	99381031	A520143C	382520 K	molla completa di pistone	245
<b>BERTOJA</b>					
	4540200	A520042	3673	membrana	34
	45402002	A520010C	3810 K	molla completa di pistone	93
	46311001	A520162C	36884K	molla completa di pistone	225
<b>BPW</b>					
	0.41.03.003.0	A520169C	3813-03 K	molla completa di pistone	110
	0.41.03.007.0	A520168C	391210-01 K	molla completa di pistone	250
	0.41.03.016.0	A520170C		molla completa di pistone	260
	02.2002.40.00	A520083	3719	membrana	40
	02.2002.41.00	A520044	3720	membrana	41
	02.2002.42.00	A520048	3762	membrana	47
	02.2002.42.00	A520084	3727	membrana	42
	02.2002.43.00	A520083	31774	membrana	74
	02.2002.44.00	A520002	3644	membrana	31
	02.2002.46.00	A520046	3662	membrana	33
	41030090	A520166C	374521 K	molla completa di pistone	243
	05.429.40.020	A520029	3881 P	molla semi-completa	121
	05.429.40.030	A520028	3941 P	molla semi-completa	130
	05.429.40.050	A520068	3942 P	molla semi-completa	133
	05.429.40.091	A520028C	3941 K	molla completa di pistone	131
	05.429.40.141	A520029C	3881-01 K	molla completa di pistone	122
	05.429.40.150	A520068C	3942-01 K	molla completa di pistone	134
	05.429.40.250	A520054	34941 P	molla semi-completa	218
	05.429.40.250	A520054C	34941 K	molla completa di pistone	219
	05.429.40.281	A520028	3941 P	molla semi-completa	130
	05.429.40.391	A520029C	3881-01 K	molla completa di pistone	122
	05.429.40.440	A520068	3942 P	molla semi-completa	133
	05.429.40.471	A520029C	3881-01 K	molla completa di pistone	122
	05.429.40.510	A520068C	3942-01 K	molla completa di pistone	134
	05.429.40.580	A520068	3942 P	molla semi-completa	133
	05.429.40.591	A520028C	3941 K	molla completa di pistone	131
	05.429.40.591	A520088C	3941- KPP	molla completa di pistone	132
	05.429.40.611	A520029C	3881-01 K	molla completa di pistone	122
	05.429.40.72.0	A520063	3951 P	molla semi-completa	136
	05.429.40.75.0	A520063	3951 P	molla semi-completa	136
	05.429.40.76.0	A520063	3951 P	molla semi-completa	136



# LISTA APPLICAZIONI

Costruttore	Rif. ORIGINALE	Rif. RNB	Rif. AIRTECH	Tipo	Pag.
	05.429.40.910	A520034	3940 P	molla semi-completa	127
	05.429.40.931	A520034	3940 P	molla semi-completa	127
	05.429.40.931	A520034C	3940 K	molla completa di pistone	128
	05.429.40.941	A520034	3940 P	molla semi-completa	127
	05.429.41.010	A520030	34881 P	molla semi-completa	206
	05.429.41.010	A520030C	34881-01 K	molla completa di pistone	207
	05.429.41.090		34942 P	molla semi-completa	
	05.429.41.211	A520029C	3881-01 K	molla completa di pistone	122
	05.429.41.231	A520034C	3940 K	molla completa di pistone	128
	05.429.41.241	A520028	3941 P	molla semi-completa	130
	05.429.41.241	A520028C	3941 K	molla completa di pistone	131
	05.429.41.241	A520088C	3941- KPP	molla completa di pistone	132
	05.429.41.281	A520028C	3941 K	molla completa di pistone	131
	05.429.41.281	A520088C	3941- KPP	molla completa di pistone	132
	05.429.41.361	A520029C	3881-01 K	molla completa di pistone	122
	05.429.41.371	A520028C	3941 K	molla completa di pistone	131
	05.429.41.371	A520088C	3941- KPP	molla completa di pistone	132
	05.429.41.380	A520068	3942 P	molla semi-completa	133
	05.429.41.380	A520068C	3942-01 K	molla completa di pistone	134
	05.429.41.510	A520034	3940 P	molla semi-completa	127
	05.429.41.510	A520034C	3940 K	molla completa di pistone	128
	05.429.41.560	A520053	34940 P	molla semi-completa	217
	05.429.41.690	A520068	3942 P	molla semi-completa	133
	05.429.41.690	A520068C	3942-01 K	molla completa di pistone	134
	05.429.41.770	A520047	34960 P	molla semi-completa	220
	05.429.42.040	A520071	34961 P	molla semi-completa	221
	05.429.43.20.0	A520088C	3941- KPP	molla completa di pistone	132
	05.429.43.21.0	A520129C	3940 KPP	molla completa di pistone	129
	05.429.43.41.0	A520130C	34881-01 KPP	molla completa di pistone	208
	05.429.43.51.0	A520087C	3881-01 KPP	molla completa di pistone	123
	05.4293.97.30	A520083	3719	membrana	40
<b>BUSSING</b>					
	536905265	A520002	3644	membrana	31
	536905266	A520002	3644	membrana	31
	831120144	A520009	3661	membrana	32
		A520046	3662	membrana	33
<b>CAMPANA</b>					
	05.020.0100	A520169C	3813-03 K	molla completa di pistone	110
	05.020.0105	A520174C	3811-02 K	molla completa di pistone	99
	05.040.200	A520144C	361421 K	molla completa di pistone	239
	05.050.0100	A520168C	391210-01 K	molla completa di pistone	250
	50400100	A520144C	361421 K	molla completa di pistone	239
<b>CARDI</b>					
	58050700	A520021C	391318 K	molla completa di pistone	255
	58050900	A520023C	391209 K	molla completa di pistone	247
	58051000	A520070C	3813 K	molla completa di pistone	107
	58051210	A520094C	34159-02 KPP	molla completa di pistone	182
<b>CHEREAU</b>					
	VSR U5 00211F	A520027	3737	membrana	44
<b>DAF</b>					
	67306	A520021C	391318 K	molla completa di pistone	255
	67306		3811 P	molla semi-completa	94
	67452		3811 P	molla semi-completa	94
	67504	A520061	3836 P	molla semi-completa	113
	297721		3836-07 K	molla completa di pistone	120
	377498		3836-01 K	molla semi-completa	97
	377498		3836-04 K	molla completa di pistone	118

# LISTA APPLICAZIONI



Costruttore	Rif. ORIGINALE	Rif. RNB	Rif. AIRTECH	Tipo	Pag.
	388165	A520061C	3836 K	molla completa di pistone	114
	388166	A520061C	3836 K	molla completa di pistone	114
	388167	A520069C	3836-02 K	molla completa di pistone	117
	388168	A520069C	3836-02 K	molla completa di pistone	117
	388169	A520069C	3836-02 K	molla completa di pistone	117
	388491	A520070C	3813 K	molla completa di pistone	107
	513982	A520040	3836-02 P	molla semi-completa	116
	513985	A520041	3836-01 P	molla semi-completa	115
	513985	A520061	3836 P	molla semi-completa	113
	526651		3836-06 K	molla completa di pistone	119
	526823	A520081C	3811 K	molla completa di pistone	95
	578361	A520046	3662	membrana	33
	627584	A520042	3673	membrana	34
	638148	A520084	3727	membrana	42
	638148	A520085	3728	membrana	43
	644425	A520002	3644	membrana	31
	656991		34154-03 K	molla completa di pistone	160
	659561	A520082	3715	membrana	38
	664425	A520048	3762	membrana	47
	676122		3811 P	molla semi-completa	94
	683392	A520082	3715	membrana	38
	689677	A520002	3644	membrana	31
	696229	A520002	3644	membrana	31
	818225	A520083	3719	membrana	40
<b>DAIMLER CHRYSLER</b>					
	A 307 328 01 01	A520044	3720	membrana	41
	A 318 328 00 01		3746	membrana	45
	A 360 328 01 01	A520044	3720	membrana	41
	A 363 229 00 01	A520082	3715	membrana	38
	A 363 328 00 01	A520082	3715	membrana	38
	A 363 328 01 01	A520044	3720	membrana	41
	A 363 328 02 01	A520077	3757	membrana	46
	A 383 327 00 01	A520042	3673	membrana	34
	A 387 328 01 01	A520044	3720	membrana	41
	A 393 328 01 01	A520027	3737	membrana	44
	A 655 327 00 01		31720	membrana	73
	A 658 328 00 01	A520086	3884	membrana	59
	A 658 328 01 01	A520039	3882	membrana	57
	A 674 328 00 01	A520111	3838	membrana	54
	A 674 328 01 01		3873	membrana	55
	A 674 328 02 01		3873	membrana	55
	A 699 328 01 01	A520039	3882	membrana	57
	A 942 320 01 17		34757-01 K	molla completa di pistone	200
	A 942 320 01 21	A520093C	34390-01 K	molla completa di pistone	191
	A 942 320 02 17		34757-02 K	molla completa di pistone	201
	A 942 320 02 21	A520098C	34390-02 K	molla completa di pistone	193
	A 942 320 03 21		34390-04 K	molla completa di pistone	
	A 942 320 04 21		34390-03 K	molla completa di pistone	
	A 942 327 00 01	A520093	34390-01 P	molla semi-completa	190
	A 942 328 00 01	A520093	34390-01 P	molla semi-completa	190
	A 942 328 01 01		34390-02 P	molla semi-completa	192
	A 946 320 03 21		34737-01 K	molla completa di pistone	198
	A 946 320 04 21	A520126	34838 P	molla semi-completa	205
	A 946 320 05 21		34737-02 K	molla completa di pistone	199
<b>DE ANGELIS</b>					
		A520070C	3813 K	molla completa di pistone	107
<b>DENNIS</b>					
	611896/ 12	A520033	3927	membrana	64
	650292/ 8	A520044	3720	membrana	41



# LISTA APPLICAZIONI

Costruttore	Rif. ORIGINALE	Rif. RNB	Rif. AIRTECH	Tipo	Pag.
	650883/ 7/ 4	A520044	3720	membrana	41
<b>DISCOS / MERCEDES</b>					
	9463280401		30081 K	molla completa di pistone	138
<b>DROGMOELLER</b>					
	440320200002-00	A520009 A520002	3661 3644	membrana membrana	32 31
<b>DUPLE</b>					
		A520078	3928	membrana	65
<b>E.R.F.</b>					
	139275-4 139855-0 143908-3	A520070C	34159-07 K 30081-01 K 3813 K	molla completa di pistone molla completa di pistone molla completa di pistone	187 139 107
<b>EMILCAMION</b>					
		A520010C A520070C	3810 K 3813 K	molla completa di pistone molla completa di pistone	93 107
<b>EURORICAMBIBUS</b>					
		A520003	3945	membrana	69
<b>EVO-BUS(Daimler-Chrysler/Kassbohrer-Setra/MB Türk)</b>					
	4.731.012.000	A520009	3661	membrana	32
	4.731.013.000	A520048	3762	membrana	47
	4.731.029.000		3811 P	molla semi-completa	94
	4.731.030.000	A520070C	3813 K	molla completa di pistone	107
	4.731.031.000	A520009	3661	membrana	32
	4.731.032.000	A520083	3719	membrana	40
	4.731.033.000	A520070C	3813 K	molla completa di pistone	107
	4.771.110.000	A520002	3644	membrana	31
	4.771.143.000	A520003	3644	membrana	31
	4.771.170.000	A520004	3644	membrana	31
	4.771.359.000	A520005	3644	membrana	31
	4.771.427.000	A520009	3661	membrana	32
	4.771.440.000	A520009	3661	membrana	32
	4.771.441.000	A520002	3644	membrana	31
	A 000.327.0101	A520003	3644	membrana	31
	A 307.328.0001	A520004	3644	membrana	31
	A 327.328.0001	A520005	3644	membrana	31
	A 356.327.0001	A520052	3450-25	membrana	84
	A 383.327.0001	A520042	3673	membrana	34
	A 942.327.0001	A520093	34390 P	molla semi-completa	
<b>FODEN</b>					
	1300248000 1300522000		34154-05 K 34156-11 K	molla completa di pistone molla completa di pistone	162 175
<b>FRUEHAUF(S.M.B,Ackerman,Netam,Crane,Acerbi,Espana,Trailor,F.France,Benalu)</b>					
	431487	A520164C	34420 K	molla completa di pistone	194
	1525199	A520094C	34159-02 KPP	molla completa di pistone	182
	UJB0129-001	A520173C	34156-03 K	molla completa di pistone	169
	003615E	A520070C	3813 K	molla completa di pistone	107
	268 0662 000	A520046	3662	membrana	33
	M001464	A520019C	391304 K	molla completa di pistone	252
	M001472	A520173C	34156-03 K	molla completa di pistone	169
	M001782	A520024C	391208 K	molla completa di pistone	246
	M060770	A520020C	391314 K	molla completa di pistone	254
	M060924	A520127C	39002-A3-01 K	molla completa di pistone	233
	UCEI2304-001		34156-09 K	molla completa di pistone	173

# LISTA APPLICAZIONI



Costruttore	Rif. ORIGINALE	Rif. RNB	Rif. AIRTECH	Tipo	Pag.
	UJA0894	A520024C	391208 K	molla completa di pistone	246
	UJB0203	A520024C	391208 K	molla completa di pistone	246
	UJB0203-001	A520128C	34159-05 K	molla completa di pistone	186
	UJB0203001	A520066C	34159-02 K	molla completa di pistone	181
	UJB0305	A520012C	391303 K	molla completa di pistone	251
	UJB0975	A520127C	39002-A3-01 K	molla completa di pistone	233
	UJB1304		34156-10 K	molla completa di pistone	174
	XCM1331	A520020C	391314 K	molla completa di pistone	254
		A520002	3644	membrana	31
		A520046	3662	membrana	33
		A520083	3719	membrana	40
<b>GIGANT</b>					
	161209	A520048	3762	membrana	47
	161210	A520048	3762	membrana	47
	166226	A520084	3727	membrana	42
	166252	A520125C	3725-01 K	molla completa di pistone	89
	196035	A520048	3762	membrana	47
	196035	A520048	3762	membrana	47
	196036	A520083	3719	membrana	40
	196043	A520084	3727	membrana	42
	246149	A520067	3725 P	molla semi-completa	87
	246149		3725 K	molla completa di pistone	88
<b>GRANNING</b>					
	15634	A520070C	3813 K	molla completa di pistone	107
	15635	A520010C	3810 K	molla completa di pistone	93
<b>HANOMAG-HENSCHEL</b>					
	536.905.265	A520009	3661	membrana	32
	536.905.266	A520009	3661	membrana	32
	546.905.134	A520002	3644	membrana	31
		A520046	3662	membrana	33
<b>HENDRICKSON</b>					
	B 2063	A520070C	3813 K	molla completa di pistone	107
	B 2065	A520010C	3810 K	molla completa di pistone	93
	B 2066		34156-05 K	molla completa di pistone	170
	B 2827		34154-02 K	molla completa di pistone	159
	B 3830		3813-05 K	molla completa di pistone	111
	B 3842		34159-07 K	molla completa di pistone	187
	B 6195		34159-08 K	molla completa di pistone	188
	C 20127		30081-01 K	molla completa di pistone	139
	HA 100001		34156-08 K	molla completa di pistone	172
	HA 100016		34156-07 K	molla completa di pistone	171
	HS 251087		30081 K	molla completa di pistone	138
	Y505801	A520070C	3813 K	molla completa di pistone	107
	Y505859	A520070C	3813 K	molla completa di pistone	107
	Y506201	A520010C	3810 K	molla completa di pistone	93
	Y506243	A520010C	3810 K	molla completa di pistone	93
	Y507782	A520020C	391314 K	molla completa di pistone	254
<b>IKARUS</b>					
	I9002		3873	membrana	55
	B 510040	A520122	3701	membrana	35
		A520002	3644	membrana	31
		A520009	3661	membrana	32
		A520046	3662	membrana	33
		A520048	3762	membrana	47
<b>INBUS</b>					
	4840001	A520035	3944	membrana	68



# LISTA APPLICAZIONI

Costruttore	Rif. ORIGINALE	Rif. RNB	Rif. AIRTECH	Tipo	Pag.
	4840005	A520035	3944	membrana	68
	4890001	A520035	3944	membrana	68
	5001051	A520026	3943	membrana	67
<b>IVECO</b>					
	174932		3809 T	molla semi-completa	91
	795097	A520032	3897	membrana	61
	2491566	A520042	3673	membrana	34
	4182227	A520009	3661	membrana	32
	4456111	A520082	3715	membrana	38
	4661868		3879 T	molla completa di pistone	
	4680913		3822 T	molla completa di pistone	
	4703904	A520065	3782	membrana	50
	4703972	A520065	3782	membrana	50
	4714019	A520035	3944	membrana	68
	4714025	A520035	3944	membrana	68
	4716989	A520003	3945	membrana	69
	4722525	A520035	3944	membrana	68
	4735768	A520035	3944	membrana	68
	4736728	A520035	3944	membrana	68
	4738008	A520035	3944	membrana	68
	4746733	A520009	3661	membrana	32
	4746740	A520027	3737	membrana	44
	4763473	A520082	3715	membrana	38
	4843220	A520153	320285	membrana	78
	5001098	A520035	3944	membrana	68
	6144040	A520026	3943	membrana	67
	6453741	A520078	3928	membrana	65
	6657150	A520035	3944	membrana	68
	8139068	A520101	3876	membrana	56
	8160165	A520026	3943	membrana	67
	42531994	A520151	320270	membrana	77
	93195986	A520065	3782	membrana	50
	93197594	A520009	3661	membrana	32
	97108021	A520035	3944	membrana	68
	97108363			membrana	
	98445471	A520154	3819	membrana	53
	98450130	A520154	3819	membrana	53
	98478799	A520031	31885	membrana	75
	99459166	A520035	3944	membrana	68
	500301452	A520086	3884	membrana	59
	500301776	A520154	3819	membrana	53
	500324098	A520152	323290	membrana	79
	536905265	A520002	3644	membrana	31
	8188526 Eurotech	A520035	3944	membrana	68
	8188539 Eurotech	A520086	3884	membrana	59
<b>KAISER</b>					
	F01001307		391305 K	molla completa di pistone	253
<b>KASSBOHRER</b>					
	4.731.012.000	A520009	3661	membrana	32
	4.731.013.000	A520048	3762	membrana	47
	4.731.030.000	A520009	3661	membrana	32
	4.731.032.000	A520083	3719	membrana	40
	4.731.033.000	A520070C	3813 K	molla completa di pistone	107
	4.771.110.000	A520002	3644	membrana	31
	4.771.117.000	A520002	3644	membrana	31
	4.771.143.000	A520002	3644	membrana	31
	4.771.359.000	A520002	3644	membrana	31
	4.771.440.000	A520009	3661	membrana	32
	4.771.441.000	A520002	3644	membrana	31



# LISTA APPLICAZIONI



Costruttore	Rif. ORIGINALE	Rif. RNB	Rif. AIRTECH	Tipo	Pag.
<b>KOGEL</b>					
	4.731.032.000	A520083	3719	membrana	40
	4.731.038.000		31774	membrana	74
		A520002	3644	membrana	31
		A520002	3644	membrana	31
		A520046	3662	membrana	33
		A520046	3662	membrana	33
		A520084	3727	membrana	42
		A520084	3727	membrana	42
<b>L.A.G</b>					
		A520032	3897	membrana	61
		A520118	3896	membrana	60
<b>LAVARAZIONI</b>					
		A520010C	3810 K	molla completa di pistone	93
		A520049C	391320 K	molla completa di pistone	257
<b>LECINENA</b>					
			3725 K	molla completa di pistone	88
<b>LECITRAILER</b>					
		A520010C	3810 K	molla completa di pistone	93
		A520012C	391303 K	molla completa di pistone	251
		A520020C	391314 K	molla completa di pistone	254
<b>LEYLAND</b>					
	10904403	A520078	3928	membrana	65
	AAU2542	A520033	3927	membrana	64
	AAU2544	A520078	3928	membrana	65
<b>LUDEWIG</b>					
		A520002	3644	membrana	31
<b>MAN</b>					
	81.436.010.017	A520002	3644	membrana	31
	81.436.010.018	A520046	3662	membrana	33
	81.436.010.025		3809 T	molla semi-completa	91
	81.436.010.032	A520039	3882	membrana	57
	81.436.010.033	A520044	3720	membrana	41
	81.436.010.036	A520044	3720	membrana	41
	81.436.010.037	A520044	3720	membrana	41
	81.436.010.039	A520076	3716	membrana	39
	81.436.010.040	A520076	3716	membrana	39
	81.436.010.042		34810 T	molla semi-completa	202
	81.436.010.044		3808 T	molla semi-completa	90
	81.436.010.047		34810 T	molla semi-completa	202
	81.436.010.049	A520048	3762	membrana	47
	81.436.010.050		3909 T	molla semi-completa	125
	81.436.010.051	A520046	3662	membrana	33
	81.436.010.052	A520048	3762	membrana	47
	81.436.010.053	A520038	3786	membrana	51
	81.436.010.054		3909 T	molla semi-completa	125
	81.436.010.056	A520084	3727	membrana	42
	81.436.010.057	A520084	3727	membrana	42
	81.436.010.058	A520084	3727	membrana	42
	81.436.010.059	A520082	3715	membrana	38
	81.436.010.060	A520082	3715	membrana	38
	81.436.010.061	A520082	3715	membrana	38
	81.436.010.065	A520039	3882	membrana	57
	81.436.010.066	A520086	3884	membrana	59
	81.436.010.067	A520039	3882	membrana	57



# LISTA APPLICAZIONI

Costruttore	Rif. ORIGINALE	Rif. RNB	Rif. AIRTECH	Tipo	Pag.
	81.436.010.067	A520044	3720	membrana	41
	81.436.010.068	A520086	3884	membrana	59
	81.436.010.069	A520086	3884	membrana	59
	81.436.010.070	A520039	3882	membrana	57
	81.436.010.071	A520096	3883	membrana	58
	81.436.010.072	A520096	3883	membrana	58
	81.436.010.073		3909 T	molla semi-completa	125
	81.436.010.075	A520082	3715	membrana	38
	81.436.010.076	A520084	3727	membrana	42
	81.436.010.078	A520082	3715	membrana	38
	81.436.010.079	A520084	3727	membrana	42
	81.436.010.081	A520082	3715	membrana	38
	81.436.010.082	A520084	3727	membrana	42
	81.436.010.083	A520082	3715	membrana	38
	81.436.010.084	A520084	3727	membrana	42
	81.436.010.090	A520082	3715	membrana	38
	81.436.010.091	A520084	3727	membrana	42
	81.436.010.092	A520039	3882	membrana	57
	81.436.010.093	A520039	3882	membrana	57
	81.436.010.094	A520039	3882	membrana	57
	81.436.010.095	A520097	3916	membrana	62
	81.436.010.096		3706	membrana	36
	81.436.010.097	A520097	3916	membrana	62
	81.436.010.098		3706	membrana	36
	81.436.010.099	A520039	3882	membrana	57
	81.436.010.100	A520039	3882	membrana	57
	81.436.010.101		3706	membrana	36
	81.436.010.102	A520097	3916	membrana	62
	81.436.010.103	A520039	3882	membrana	57
	81.436.010.104	A520031	31885	membrana	75
	81.436.010.105	A520097	3916	membrana	62
	81.436.010.106	A520086	3884	membrana	59
	81.436.010.108	A520086	3884	membrana	59
	81.436.010.109	A520031	31885	membrana	75
	81.436.010.110	A520096	3883	membrana	58
	81.436.010.111	A520031	31885	membrana	75
	81.436.010.113	A520082	3715	membrana	38
	81.436.010.114	A520084	3727	membrana	42
	81.436.010.115	A520082	3715	membrana	38
	81.436.010.116	A520084	3727	membrana	42
	81.436.010.117	A520082	3715	membrana	38
	81.436.010.118	A520084	3727	membrana	42
	81.436.010.120	A520031	31885	membrana	75
	81.436.010.121	A520039	3882	membrana	57
	81.436.010.123	A520031	31885	membrana	75
	81.436.010.125	A520031	31885	membrana	75
	81.436.010.126	A520097	3916	membrana	62
	81.436.010.127		3706	membrana	36
	81.436.010.128	A520096	3883	membrana	58
	81.436.010.138	A520097	3916	membrana	62
	81.436.010.139		3706	membrana	36
	81.436.010.140	A520031	31885	membrana	75
	81.436.010.144	A520044	3720	membrana	41
	81.436.010.150	A520031	31885	membrana	75
	81.436.016.002		3809 T	molla semi-completa	91
	81.436.016.019		34810 T	molla semi-completa	202
	81.436.016.050		3809 T	molla semi-completa	91
	81.436.016.060	A520076	3716	membrana	39
	81.436.016.069	A520076	3716	membrana	39
	81.436.016.075	A520076	3716	membrana	39
	90.831.120.018	A520046	3662	membrana	33
	90.831.120.144	A520009	3661	membrana	32

# LISTA APPLICAZIONI



Costruttore	Rif. ORIGINALE	Rif. RNB	Rif. AIRTECH	Tipo	Pag.
<b>MAGIRUS-DEUTZ</b>					
	2491566	A520042	3673	membrana	34
	2498667	A520009	3661	membrana	32
	4456111	A520082	3715	membrana	38
	41822247	A520009	3661	membrana	32
	536905265	A520002	3644	membrana	31
<b>MENARINI</b>					
	173201		3879T	molla semi-completa	
	178471	A520065	3782	membrana	50
	178623	A520035	3944	membrana	68
	178739	A520027	3737	membrana	44
	178741	A520003	3945	membrana	69
	192709	A520154	3819	membrana	53
	199196	A520002	3644	membrana	31
	252933	A520099	3769	membrana	49
	325993	A520035	3944	membrana	68
	D020990	A520151	320270	membrana	77
	D031105	A520039	3882	membrana	57
<b>MENCI</b>					
		A520021C	391318 K	molla completa di pistone	255
		A520036C	39002-A3 K	molla completa di pistone	232
<b>MERCEDES</b>					
	307.327.010	A520002	3644	membrana	31
	3.073.270.101	A520003	3644	membrana	31
	3.073.280.101	A520084	3727	membrana	42
	364.327.70.01	A520002	3644	membrana	31
	382.327.71.01	A520048	3762	membrana	47
	382.327.72.01	A520065	3782	membrana	50
		A520046	3662	membrana	33
<b>METRO-CAMMELL</b>					
	X 664 1056	A520044	3720	membrana	41
		A520033	3927	membrana	64
<b>MICHIELETTO</b>					
	1004	A520074C	391323 K	molla completa di pistone	258
<b>MIELE</b>					
		A520010C	3810 K	molla completa di pistone	93
		A520012C	391303 K	molla completa di pistone	251
		A520049C	391320 K	molla completa di pistone	257
<b>MONTENEGRO</b>					
		A520020C	391314 K	molla completa di pistone	254
		A520024C	391208 K	molla completa di pistone	246
		A520066C	34159-02 K	molla completa di pistone	181
<b>NEOPLAN</b>					
	1001 10 300	A520002	3644	membrana	31
	1001 101 00	A520083	3719	membrana	40
	1001 102 00	A520046	3662	membrana	33
	1001 12 250	A520009	3661	membrana	32
	1001 12 254	A520002	3644	membrana	31
	1001 121 00		3788	membrana	52
	1001 122 51	A520046	3662	membrana	33
	1001 123 00	A520044	3720	membrana	41
	1021 002 00	A520083	3719	membrana	40
	1021 003 00	A520048	3762	membrana	47



# LISTA APPLICAZIONI



Costruttore	Rif. ORIGINALE	Rif. RNB	Rif. AIRTECH	Tipo	Pag.
<b>PRIMBALL</b>					
		A520029C	3881-01 K	molla completa di pistone	122
		A520030C	34881-01 K	molla completa di pistone	207
<b>R.O.R / MERITOR</b>					
	21208082	A520010C	3810 K	molla completa di pistone	93
	21215632	A520010C	3810 K	molla completa di pistone	93
	21215633	A520010C	3810 K	molla completa di pistone	93
	21215761	A520070C	3813 K	molla completa di pistone	107
	21215762		34156-08 K	molla completa di pistone	172
	21215762	A520089C	34156 KPP	molla completa di pistone	165
	21215801		34156-08 K	molla completa di pistone	172
	21216135	A520066C	34159-02 K	molla completa di pistone	181
	21221307	A520066C	34159-02 K	molla completa di pistone	181
	21221349	A520133C	34157 KP	molla completa di pistone	176
	21222239	A520012C	391303 K	molla completa di pistone	251
	21222442		3811-02 K	molla completa di pistone	99
	21222673	A520036C	39002-A3 K	molla completa di pistone	232
	21226046		3912 K	molla completa di pistone	126
			34156-08 K	molla completa di pistone	172
<b>RENAULT V.I</b>					
	5.000.183.640		31924	membrana	76
	5.000.288.982		3921	membrana	63
	5.000.296.816	A520101	3876	membrana	56
	5.000.452.939	A520010C	3810 K	molla completa di pistone	93
	5.000.745.918	A520081C	3811 K	molla completa di pistone	95
	5.000.785.792	A520099	3769	membrana	49
	5.000.785.798	A520099	3769	membrana	49
	5.000.786.516	A520043	3768	membrana	48
	5.000.786.640	A520099	3769	membrana	49
	5.000.786.641	A520099	3769	membrana	49
	5.000.786.901	A520082	3715	membrana	38
	5.000.786.901	A520099	3769	membrana	49
	5.000.787.632	A520065	3782	membrana	50
	5.000.790.692	A520070C	3813 K	molla completa di pistone	107
	5.000.805.284	A520099	3769	membrana	49
	5.000.819.370	A520150	3936	membrana	66
	5.000.819.517	A520082	3715	membrana	38
	5.000.869.135	A520043	3768	membrana	48
	5.000.869.179	A520065	3782	membrana	50
	5.000.954.175	A520043	3768	membrana	48
	5.000.954.176	A520065	3782	membrana	50
	5.001.829.866	A520009	3661	membrana	32
	5.001.831.423	A520116	31234	membrana	70
	5.001.832.067	A520060	34912 P	molla semi-completa	211
	5.001.832.067	A520060C	34912 K	molla completa di pistone	212
	5.001.855.856	A520112	34915 P	molla semi-completa	215
	5.010.130.925	A520070C	3813 K	molla completa di pistone	107
	5.010.151.378		3921	membrana	63
	5.010.151.379		3921	membrana	63
	5.010.206.716		31924	membrana	76
	5.010.211.722		3901 K	molla completa di pistone	
	5.010.211.724		3902 K	molla completa di pistone	
	5.010.239.252	A520057C	34154 KPP	molla completa di pistone	158
	5.010.239.971	A520075C	34911 K	molla completa di pistone	210
	5.010.294.307	A520060	34912 P	molla semi-completa	211
	5.010.294.385	A520086	3884	membrana	59
	5.010.347.385		31924	membrana	76
	5.010.347.890		31924	membrana	76
	5.010.347.891		31924	membrana	76
	5.010.393.062	A520116	31234	membrana	70



# LISTA APPLICAZIONI

Costruttore	Rif. ORIGINALE	Rif. RNB	Rif. AIRTECH	Tipo	Pag.
	5.011.239.971	A520075	34911 P	molla semi-completa	209
	5.011.294.308	A520075	34911 P	molla semi-completa	209
	5.010.294.252 B		34154-06 K	molla completa di pistone	
	5.010.294.307 B	A520060 C	34912 K	molla completa di pistone	212
	5.010.294.307A	A520060C	34912 K	molla completa di pistone	212
	5.010.294.546 B	A520112	34915 P	molla semi-completa	215
		A520002	3644	membrana	31
		A520009	3661	membrana	32
<b>ROLFO</b>					
	112010	A520147C	30076 K	molla completa di pistone	137
	112060	A520021C	391318 K	molla completa di pistone	255
	112322	A520023C	391209 K	molla completa di pistone	247
<b>S.A.E</b>					
	8403 / 102	A520070C	3813 K	molla completa di pistone	107
	9212050	A520049C	391320 K	molla completa di pistone	257
<b>S.A.F</b>					
	2.228.0002.00	A520010C	3810 K	molla completa di pistone	93
	2.229.0002.00	A520010C	3810 K	molla completa di pistone	93
	2.229.0003.00	A520070C	3813 K	molla completa di pistone	107
	2.229.0007.02	A520090C	34004 KPP	molla completa di pistone	148
	2.229.2107.00	A520062	34004 P	molla semi-completa	146
	2618V		32618 K	molla completa di pistone	144
	2619V	A520131C	32619 KPP	molla completa di pistone	143
	2918V	A520146C	32918 K	molla completa di pistone	144
	2923V	A520059C	34023 K	molla completa di pistone	155
	2926V	A520132C	32926 K	molla completa di pistone	145
	3.228.0002.00	A520010C	3810 K	molla completa di pistone	93
	3.229.0003.00	A520070C	3813 K	molla completa di pistone	107
	3.229.0005.00	A520056C	34813 K	molla completa di pistone	204
	3.229.0005.01		3912 K	molla completa di pistone	126
	3.229.0006.01	A520056C	34813 K	molla completa di pistone	204
	3.229.0006.01		3912 K	molla completa di pistone	126
	3.229.0007.00	A520062	34004 P	molla semi-completa	146
	3.229.0007.00	A520090C	34004 KPP	molla completa di pistone	148
	3.229.0007.01	A520090C	34004 KPP	molla completa di pistone	148
	3.229.0007.02	A520090C	34004 KPP	molla completa di pistone	148
	3.229.0013.00	A520056C	34813 K	molla completa di pistone	204
	3.229.0013.00		3912 K	molla completa di pistone	126
	3.229.0013.01	A520056C	34813 K	molla completa di pistone	204
	3.229.0024.00	A520012C	391303 K	molla completa di pistone	251
	3.229.0027.00	A520146C	32918 K	molla completa di pistone	144
	3.229.0029.00	A520055C	34022 K	molla completa di pistone	150
	3.229.0029.00	A520095C	34022 KPP	molla completa di pistone	151
	3.229.0030.00	A520132C	32926 K	molla completa di pistone	145
	3.229.0031.00	A520059C	34023 K	molla completa di pistone	155
	3.229.0031.00		3811-01 K	molla completa di pistone	97
	3.229.0033.00	A520131C	32619 KPP	molla completa di pistone	143
	3.229.2630.00	A520132C	32926 K	molla completa di pistone	145
	4.2843003.01	A520090C	34004 KPP	molla completa di pistone	148
<b>SAMRO</b>					
	2500008	A520010C	3810 K	molla completa di pistone	93
	2500009	A520070C	3813 K	molla completa di pistone	107
	2500425	A520024C	391208 K	molla completa di pistone	246
	2500915		30081 K	molla completa di pistone	138
	H25000324	A520094C	34159-02 KPP	molla completa di pistone	182
	H25000361	A520012C	391303 K	molla completa di pistone	251

# LISTA APPLICAZIONI



Costruttore	Rif. ORIGINALE	Rif. RNB	Rif. AIRTECH	Tipo	Pag.
<b>SCANIA + SCANIA BUSSAR</b>					
	255293	A520056C	34813 K	molla completa di pistone	204
	255294		34159-09 K	molla completa di pistone	189
	255295	A520056C	34813 K	molla completa di pistone	204
	298568	A520056C	34813 K	molla completa di pistone	204
	325748	A520056C	34813 K	molla completa di pistone	204
	402315	A520032	3897	membrana	61
	411622	A520032	3897	membrana	61
	411623	A520032	3897	membrana	61
	411627	A520118	3896	membrana	60
	424626	A520033	3927	membrana	64
	434932	A520078	3928	membrana	65
	523229	A520035	3944	membrana	68
	934094	A520033	3927	membrana	64
	1107674	A520056C	34813 K	molla completa di pistone	204
	1314906	A520056C	34813 K	molla completa di pistone	204
	1362145	A520140C	36199 K	molla completa di pistone	222
	1362147	A520139C	36200 K	molla completa di pistone	223
	1370743	A520140C	36199 K	molla completa di pistone	222
	1370744	A520139C	36200 K	molla completa di pistone	223
	1379392	A520045C	34913 K	molla completa di pistone	214
	1379393	A520045C	34913 P	molla semi-completa	213
	1386199	A520140C	36199 K	molla completa di pistone	222
	1386200	A520139C	36200 K	molla completa di pistone	223
	1440294	A520045C	34913 K	molla completa di pistone	214
	10904403	A520033	3927	membrana	64
		A520002	3644	membrana	31
		A520042	3673	membrana	34
		A520076	3716	membrana	39
		A520082	3715	membrana	38
		A520099	3769	membrana	49
<b>SCHMITZ</b>					
	750208	A520009	3661	membrana	32
	750209	A520046	3662	membrana	33
	750212	A520084	3727	membrana	42
	750212	A520085	3728	membrana	43
	750215	A520083	3719	membrana	40
	750225		31774	membrana	74
	750999	A520091C	34158-KPP	molla completa di pistone	178
	751065		34158 P	molla semi-completa	177
	751065	A520165C	38186 KPP	molla completa di pistone	228
<b>SEDDON ATKINSON</b>					
		A520002	3644	membrana	31
		A520009	3661	membrana	32
		A520010C	3810 K	molla completa di pistone	93
		A520070C	3813 K	molla completa di pistone	107
<b>STEYR</b>					
		A520010C	3810 K	molla completa di pistone	93
		A520070C	3813 K	molla completa di pistone	107
<b>T.E.C</b>					
	505801	A520070C	3813 K	molla completa di pistone	107
	505859	A520070C	3813 K	molla completa di pistone	107
	506003		3813-05 K	molla completa di pistone	111
	506201	A520010C	3810 K	molla completa di pistone	93
	506243	A520010C	3810 K	molla completa di pistone	93
	507505		34156-09 K	molla completa di pistone	173



# LISTA APPLICAZIONI

Costruttore	Rif. ORIGINALE	Rif. RNB	Rif. AIRTECH	Tipo	Pag.
<b>TERBERG</b>					
	21071483	A520070C	3813 K	molla completa di pistone	107
<b>TITAN</b>					
	91687700000	A520070C	3813 K	molla completa di pistone	107
<b>TOUGHLINE</b>					
		A520010C	3810 K	molla completa di pistone	93
		A520036C	39002-A3 K	molla completa di pistone	232
			3811-06 P	molla semi-completa	100
<b>TRAILOR</b>					
	0036158E	A520070C	3813 K	molla completa di pistone	107
	650234Y	A520070C	3813 K	molla completa di pistone	107
	6504646G	A520010C	3810 K	molla completa di pistone	93
<b>TRAS CAR</b>					
	3003000060	A520145C	361481 K	molla completa di pistone	241
	3003000070	A520144C	361421 K	molla completa di pistone	239
<b>TROUILLET</b>					
	F01008696		391309 K	molla completa di pistone	
	HB10315	A520010C	3810 K	molla completa di pistone	93
	HB10315	A520049C	391320 K	molla completa di pistone	257
	HT1802	A520094C	34159-02 KPP	molla completa di pistone	182
	HT1803		391309 K	molla completa di pistone	
<b>VAN HOOL</b>					
	3422596	A520046	3662	membrana	33
	624319-420	A520003	3644	membrana	31
	624319-460	A520048	3762	membrana	47
	624319-600	A520002	3644	membrana	31
	624319-610	A520003	3644	membrana	31
	624319-614	A520084	3727	membrana	42
	624319-630	A520002	3644	membrana	31
	624319-640	A520084	3727	membrana	42
	624319-670	A520009	3661	membrana	32
	624319-680	A520048	3762	membrana	47
	624319-690	A520009	3661	membrana	32
	624319-700	A520009	3661	membrana	32
	624319-710	A520099	3769	membrana	49
	624319-860	A520042	3673	membrana	34
		A520046	3662	membrana	33
<b>VIBERTI</b>					
	644225	A520070C	3813 K	molla completa di pistone	107
	128147102	A520021C	391318 K	molla completa di pistone	255
	128147109	A520006C	391210 K	molla completa di pistone	248
	128147111	A520006C/I	391210 K/I	molla completa di pistone	249
	128147112	A520021C/I	391318 K/I	molla completa di pistone	256
	128147122	A520070C	3813 K	molla completa di pistone	107
	128147123	A520094C	34159-02 KPP	molla completa di pistone	182
<b>VOLVO</b>					
	1075290	A520092	31421	membrana	72
	1075363	A520121C	34718 K	molla completa di pistone	197
	1075364	A520172C	39780 K	molla completa di pistone	237
	1075365	A520120C	34925 K	molla completa di pistone	216
	1075366		31924	membrana	76
	1076416	A520175C	36416 K	molla completa di pistone	224
	1076594	A520072C	34713 K	molla completa di pistone	196
	1076595	A520072C	34713 K	molla completa di pistone	196



# LISTA APPLICAZIONI



Costruttore	Rif. ORIGINALE	Rif. RNB	Rif. AIRTECH	Tipo	Pag.
	1080707	A520010C	3810 K	molla completa di pistone	93
	1082085	A520096	3883	membrana	58
	1134445	A520002	3644	membrana	31
	1134446	A520084	3727	membrana	42
	1137882	A520009	3661	membrana	32
	1137888	A520009	3661	membrana	32
	1159842	A520097	3916	membrana	62
	1199873	A520002	3644	membrana	31
	1199893	A520002	3644	membrana	31
	1590136	A520044	3720	membrana	41
	1593842	A520076	3716	membrana	39
	1593843	A520076	3716	membrana	39
	1611776	A520042	3673	membrana	34
	1612455	A520043	3768	membrana	48
	1622111	A520002	3644	membrana	31
	1622115	A520092	31421	membrana	72
	1622116	A520064	3713	membrana	37
	1629193	A520044	3720	membrana	41
	1629718	A520121C	34718 K	molla completa di pistone	197
	1629780	20172C	39780 K	molla completa di pistone	237
	1629782	A520120C	34925 K	molla completa di pistone	216
	3027271	A520050	3415-25	membrana	80
	3027272	A520051	3415-28	membrana	81
	3111277	A520124	31277	membrana	71
	3116354	A520033	3927	membrana	64
	3116983	A520078	3928	membrana	65
	3159252	A520002	3644	membrana	31
	3159253	A520009	3661	membrana	32
	6135049	A520042	3673	membrana	34
	6782726		3788	membrana	52
	6797169	A520064	3713	membrana	37
	6885533	A520082	3715	membrana	38
	8147475	A520116	31234	membrana	70
	8158106	A520072	34713 P	molla semi-completa	195
	8158106	A520072C	34713 K	molla completa di pistone	196
	20456152	A520175C	36416 K	molla completa di pistone	224
	20427803		37803 P	molla semi-completa	227
	3.112.775.291	A520124	31277	membrana	71
	AAU 2542	A520033	3927	membrana	64
		A520010C	3810 K	molla completa di pistone	93
<b>WACKENHUT</b>					
		A520046	3662	membrana	33
		A520077	3757	membrana	46
		A520083	3719	membrana	40
		A520084	3727	membrana	42
<b>WARSTEINER</b>					
		A520002	3644	membrana	31
		A520044	3720	membrana	41
		A520046	3662	membrana	33
		A520048	3762	membrana	47
		A520083	3719	membrana	40
		A520084	3727	membrana	42
<b>WEWELER</b>					
	21208082	A520010C	3810 K	molla completa di pistone	93
	1535864F	A520066C	34159-02 K	molla completa di pistone	181
	US00622	A520010C	3810 K	molla completa di pistone	93
	US06285F	A520091C	34158-KPP	molla completa di pistone	178
	US06316		34158	membrana	177
	US06316F	A520165C	38186 KPP	molla completa di pistone	228



## LISTA APPLICAZIONI

Costruttore	Rif. ORIGINALE	Rif. RNB	Rif. AIRTECH	Tipo	Pag.
	US06345	A520010C	3810 K	molla completa di pistone	93
	US06364	A520070C	3813 K	molla completa di pistone	107
	US07074	A520036C	39002-A3 K	molla completa di pistone	232
	US07337	A520010C	3810 K	molla completa di pistone	93
	US07337F	A520049C	391320 K	molla completa di pistone	107
	US07345	A520070C	3813 K	molla completa di pistone	257
	US07380	A520012C	391303 K	molla completa di pistone	251
	US07385F	A520020C	391314 K	molla completa di pistone	254
	US09361F		34156-08 K	molla completa di pistone	172
	US35864		34156-08 K	molla completa di pistone	172
	US87408	A520070C	3813 K	molla completa di pistone	107
	US874131F	A520010C	3810 K	molla completa di pistone	93
	US874313	A520010C	3810 K	molla completa di pistone	93
	US87EURO	A520037C	39002-08 K	molla completa di pistone	
	US96681		3912 K	molla completa di pistone	126
<b>YORK</b>					
	506243/01	A520049C	391320 K	molla completa di pistone	257
	785168	A520010C	3810 K	molla completa di pistone	93
	785170	A520070C	3813 K	molla completa di pistone	107
<b>ZORZI</b>					
	1006545	A520163C	36885K	molla completa di pistone	226
	1006546	A520162C	36884K	molla completa di pistone	225
	1006551	A520023C	391209 K	molla completa di pistone	247
	1006552	A520019C	391304 K	molla completa di pistone	252
	1006553	A520021C	391318 K	molla completa di pistone	255
	1006557	A520147C	30076 K	molla completa di pistone	137

## MOLLE AD ARIA A LOBI

Costruttore	Rif. ORIGINALE	Rif. RNB	Rif. AIRTECH	Tipo	Pag.
<b>AUSTERAS</b>					
	99381001	A520171C		molle ad aria a lobi	278
	99381024	A520137	2B-370-Hyd / 113361	molle ad aria a lobi	272
<b>BARTOLETTI</b>					
	91621110	A520171C		molle ad aria a lobi	278
	91621322	A520136	3B-300-Hyd / 115005	molle ad aria a lobi	276
<b>BATTAGLINO</b>					
	041040040	A520137	2B-370-Hyd / 113361	molle ad aria a lobi	272
	22.070.00	A520171C		molle ad aria a lobi	278
<b>BENALU</b>					
	M00 2297	A520107	3B-300 / 1150042	molle ad aria a lobi	275
	M 063 796	A520110	2B-300 / 113301	molle ad aria a lobi	270
<b>B.P.W.</b>					
	02 2002 05 00	A520123	2B-285 / 114250	molle ad aria a lobi	268
	22.070.00	A520171C		molle ad aria a lobi	278
<b>CAMPANA</b>					
	050500400	A520137	2B-370-Hyd / 113361	molle ad aria a lobi	272
<b>CARDI</b>					
	58053300	A520137	2B-370-Hyd / 113361	molle ad aria a lobi	272
<b>DAF</b>					
	0654464	A520079	2B-220 / 113001	molle ad aria a lobi	265

# LISTA APPLICAZIONI



Costruttore	Rif. ORIGINALE	Rif. RNB	Rif. AIRTECH	Tipo	Pag.
<b>FRUEHAUF</b>					
	F48054M80A04	A520141	2B-200 / 113060	molle ad aria a lobi	264
	M 002 297	A520107	3B-300 / 115004	molle ad aria a lobi	275
	UJB 09 85/A	A520110	2B-300 / 113301	molle ad aria a lobi	270
<b>GIGANT</b>					
	881202	A520109	2B-300 / 113300	molle ad aria a lobi	269
	881204	A520113	3B-300 / 115003	molle ad aria a lobi	274
<b>GRANNING</b>					
	15599	A520106	2B-220-3 / 113002	molle ad aria a lobi	266
	15603	A520079	2B-220 / 113001	molle ad aria a lobi	265
	15803	A520141	2B-200 / 113060	molle ad aria a lobi	264
	15807	A520119	2B-255 / 113100	molle ad aria a lobi	267
	15813	A520109	2B-300 / 113300	molle ad aria a lobi	269
	15814	A520110	2B-300 / 113301	molle ad aria a lobi	270
	15815	A520135	2B-300 / 114300	molle ad aria a lobi	271
	15816	A520113	3B-300 / 115003	molle ad aria a lobi	274
	15832	A520114	3B-400-Hyd / 115155	molle ad aria a lobi	277
	15897	A520107	3B-300 / 115004	molle ad aria a lobi	275
	15923	A520123	2B-285 / 114250	molle ad aria a lobi	268
<b>HENDRICKSON-DISCOS</b>					
	NA 1827	A520079	2B-220 / 113001	molle ad aria a lobi	265
<b>IVECO</b>					
	42107595	A520136	3B-300-Hyd / 115005	molle ad aria a lobi	276
	8194818	A520137	2B-370-Hyd / 113361	molle ad aria a lobi	272
<b>KAISER</b>					
	A 060 30 615	A520110	2B-300 / 113301	molle ad aria a lobi	270
	A 060 30 616	A520135	2B-300 / 114300	molle ad aria a lobi	271
	WC 074 0236	A520114	3B-400-Hyd / 115155	molle ad aria a lobi	277
<b>KASSBOHRER</b>					
	4731003000	A520123	2B-285 / 114250	molle ad aria a lobi	268
<b>LOHR</b>					
	A 060 30 604	A520141	2B-200 / 113060	molle ad aria a lobi	264
	A 060 30 606	A520107	3B-300 / 115004	molle ad aria a lobi	275
	A 063 06 01	A520110	2B-300 / 113301	molle ad aria a lobi	270
	Y 000 01 737	A520135	2B-300 / 114300	molle ad aria a lobi	271
<b>MAGIRUS</b>					
	0342 2571	A520123	2B-285 / 114250	molle ad aria a lobi	268
<b>MAN</b>					
	81 43601 0022	A520123	2B-285 / 114250	molle ad aria a lobi	268
	88 96420 0217	A520123	2B-285 / 114250	molle ad aria a lobi	268
<b>MERITOR</b>					
	21221395	A520079	2B-220 / 113001	molle ad aria a lobi	265
	21222663	A520079	2B-220 / 113001	molle ad aria a lobi	265
<b>METRO BUS</b>					
	X 664 1055	A520135	2B-300 / 114300	molle ad aria a lobi	271
<b>PEGASO</b>					
	528919 / 5266 / 5231 / 5236	A520079	2B-220 / 113001	molle ad aria a lobi	265
<b>R.O.R. / MERITOR</b>					
	21212549	A520171C		molle ad aria a lobi	278



# LISTA APPLICAZIONI

Costruttore	Rif. ORIGINALE	Rif. RNB	Rif. AIRTECH	Tipo	Pag.
	21221395 21222663	A520079 A520079	2B-220 / 113001 2B-220 / 113001	molle ad aria a lobi molle ad aria a lobi	265 265
<b>SAF</b>					
	1600 4.229.1004.00	A520106	2B-220-3 / 113002	molle ad aria a lobi	266
<b>SAMRO</b>					
	H 250-0011 H 250-0021 H 250-0188	A520107 A520119 A520141	3B-300 / 115004 2B-255 / 113100 2B-200 / 113060	molle ad aria a lobi molle ad aria a lobi molle ad aria a lobi	275 267 264
<b>SCANIA</b>					
	131 9761 138 7289	A520106 A520106	2B-220-3 / 113002 2B-220-3 / 113002	molle ad aria a lobi molle ad aria a lobi	266 266
<b>SMB</b>					
	M 002 297 M 063 796	A520107 A520110	3B-300 / 115004 2B-300 / 113301	molle ad aria a lobi molle ad aria a lobi	275 270
<b>STEFEN</b>					
	19141000	A520171C	3B-300 Hyd / 115005	molle ad aria a lobi	278
<b>TRAILOR</b>					
	UJB 09 85/A	A520110	2B-300 / 113301	molle ad aria a lobi	270
<b>TRAS CAR</b>					
	03003000020 03003000040	A520137 A520171C	2B-370-Hyd / 113361	molle ad aria a lobi molle ad aria a lobi	272 278
<b>TROUILLET</b>					
	HB 10350	A520110	2B-300 / 113301	molle ad aria a lobi	270
<b>VIBERTI</b>					
	128 118 102 128 118 103	A520137 A520136	2B-370-Hyd / 113361 3B-300-Hyd / 115005	molle ad aria a lobi molle ad aria a lobi	272 276
<b>VOLVO</b>					
	365461 365431 6882797	A520079 A520079 A520079	2B-220 / 113001 2B-220 / 113001 2B-220 / 113001	molle ad aria a lobi molle ad aria a lobi molle ad aria a lobi	265 265 265
<b>WEWELER</b>					
	US 06910 F USN 5100 I I KD	A520079 A520109	2B-220 / 113001 2B-300 / 113300	molle ad aria a lobi molle ad aria a lobi	265 269
<b>ZORZI</b>					
	100 6505 100 6508	A520136 A520171C		molle ad aria a lobi	276 278

# LISTA APPLICAZIONI



## MOLLE AD ARIA PER SEDILI

Costruttore	Rif. ORIGINALE	Rif. RNB	Rif. AIRTECH	Tipo	Pag.
<b>ISRINGHAUSEN</b>					
	3,1390	A520105	I25104	Molle aria per sedili	284
	3,1396	A520103	I25102	Molle aria per sedili	282
	3,3207	A520104	I25103	Molle aria per sedili	283
<b>VOLVO</b>					
	1081785	A520138	I26001	Molle aria per sedili	285



MEMBRANE









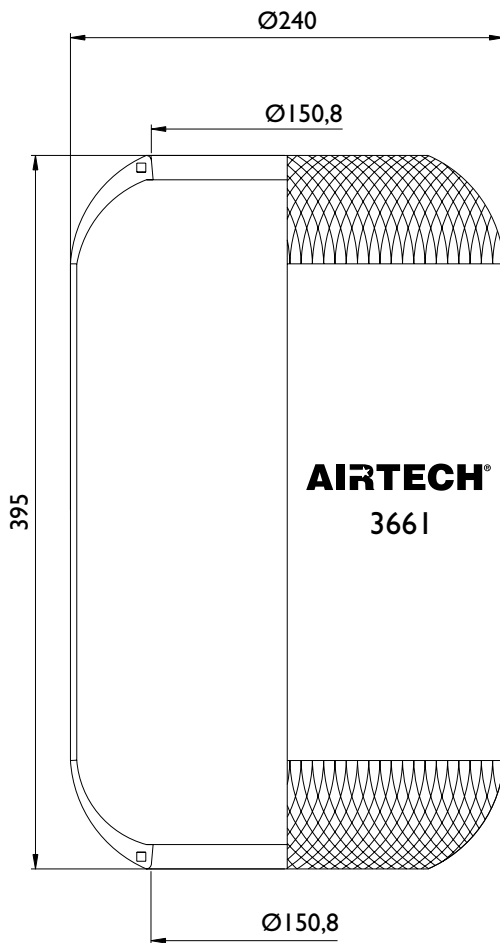

### Applicazioni principali

BUSSING	831120144
EVO -BUS	4.731.012.000
EVO -BUS	4.731.031.000
EVO -BUS	4.771.427.000
HANOMAG-HENSCHEL	536.905.265
HANOMAG-HENSCHEL	536.905.266
IVECO - FIAT	4182227
IVECO - FIAT	4746733
IVECO BUS 470	93197594
KASSBOHRER - SETRA	4.731.012.000
KASSBOHRER - SETRA	4.771.440.000
MAGIRUS - DEUTZ	02498667
MAGIRUS - DEUTZ	041822247
MAN	90.831.120.144
NEOPLAN	1001.101.00
NEOPLAN	1001.122.50
NEOPLAN	1021.002.00
NEOPLAN	AA 10 - 01 - 001
RVI	5001829866
SCHMITZ	750208
VAN HOOL	624319-690
VOLVO	1137882 /88

### Lista corrispondenze

CONTITECH	661 N
FIRESTONE	1R1C 390-310 / W01 095 0021
PHOENIX	1E 25
TAURUS	BL 114
DUNLOP UK	PNP 304980101
DUNLOP F	D12 S02
GOODYEAR	8018
PIRELLI	1 S 310-28 / 91016
GART	D297 297.0.390

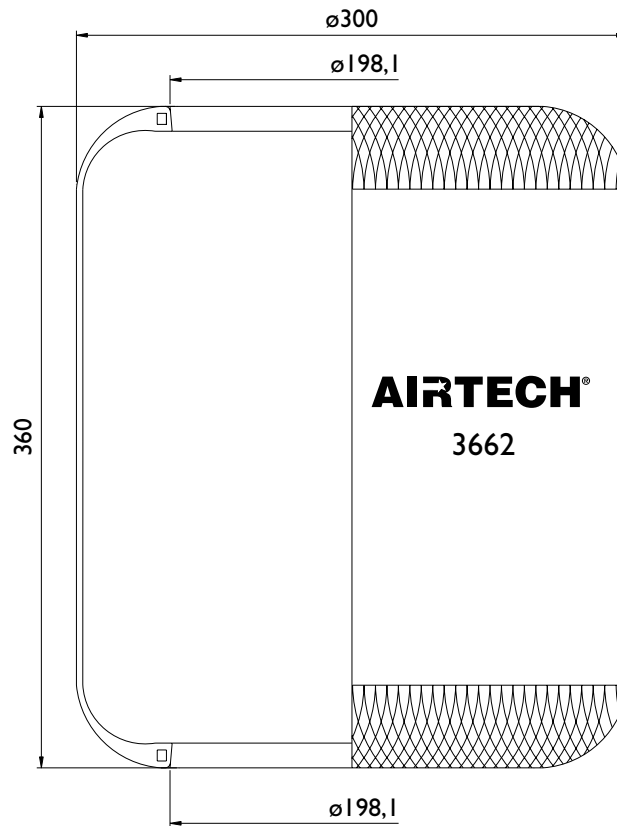

**Applicazioni principali**

BPW	02.2002.4600
DAF	578361
FRÜEHAUF	268.0662.000
MAN	81.43601.0018 / 51
MAN	90.83112.0018
NEOPLAN	1001.102.00
NEOPLAN	1001.12.251
NEOPLAN	AA10 - 01 - 002
SCHMITZ	750209
VAN HOOL	3422596

**Lista corrispondenze**

CONTITECH	662 N
FIRESTONE	IRID 355-355 / W01 095 0207
PHOENIX	IE 32
TAURUS	BL 143
DUNLOP UK	PNP 302730101
DUNLOP F	
GOODYEAR	9007
PIRELLI	I SC 360-30 - 92594
GART	

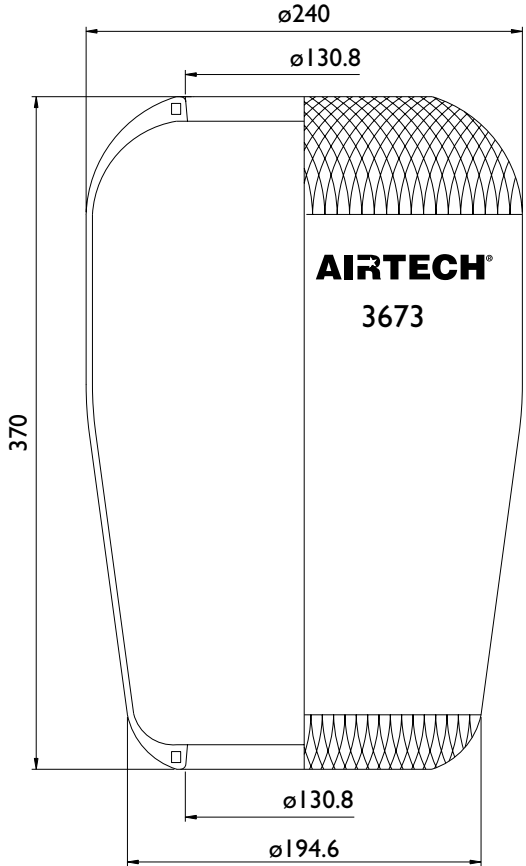

**Applicazioni principali**

DAF	627584
MAGIRUS	249 1566
MERCEDES	3833270001
VOLVO	1611776
VOLVO	6135049

**Lista corrispondenze**

CONTITECH	673 N
FIRESTONE	
PHOENIX	1F 21A
TAURUS	B 141
DUNLOP UK	
DUNLOP F	
GOODYEAR	
PIRELLI	
GART	

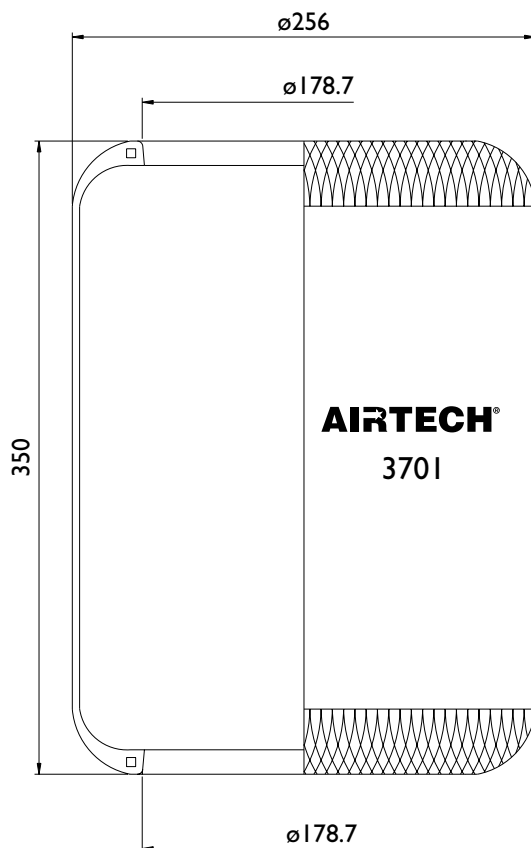

**Applicazioni principali**

AUWARTER	B510040

**Lista corrispondenze**

CONTITECH	701 N
FIRESTONE	IR3M 340-340 / W01 095 0205
PHOENIX	IE 26-1
TAURUS	B 116-1
DUNLOP UK	
DUNLOP F	
GOODYEAR	9006
PIRELLI	
GART	

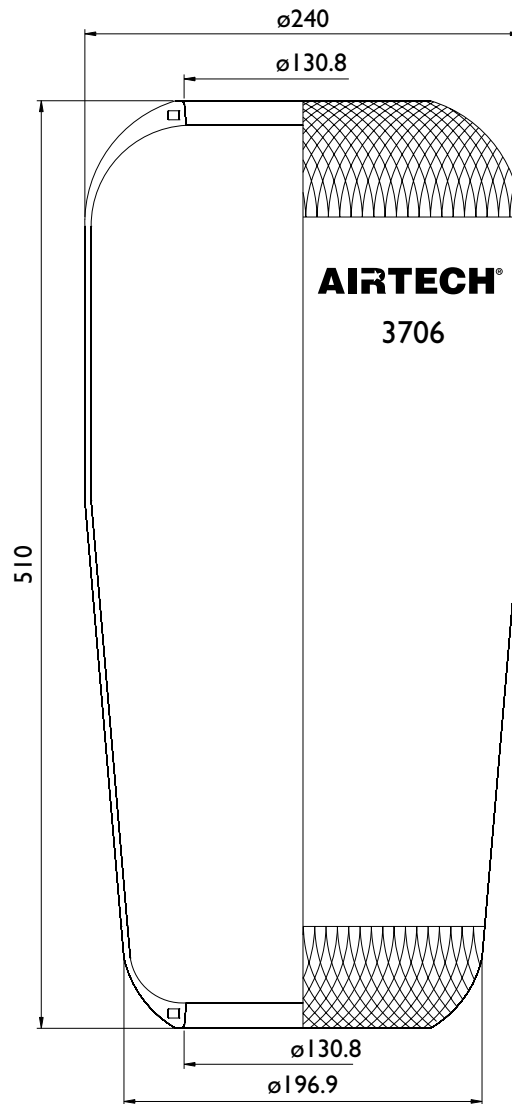
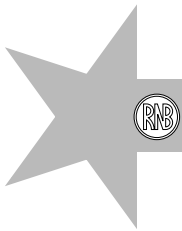

**Applicazioni principali**

MAN	81.43601.0096
MAN	81.43601.0098
MAN	81.43601.0101
MAN	81.43601.0139
MAN (3° ASSE)	81.43601.0127

**Lista corrispondenze**

CONTITECH	706 N
FIRESTONE	
PHOENIX	
TAURUS	
DUNLOP UK	
DUNLOP F	
GOODYEAR	
PIRELLI	
GART	

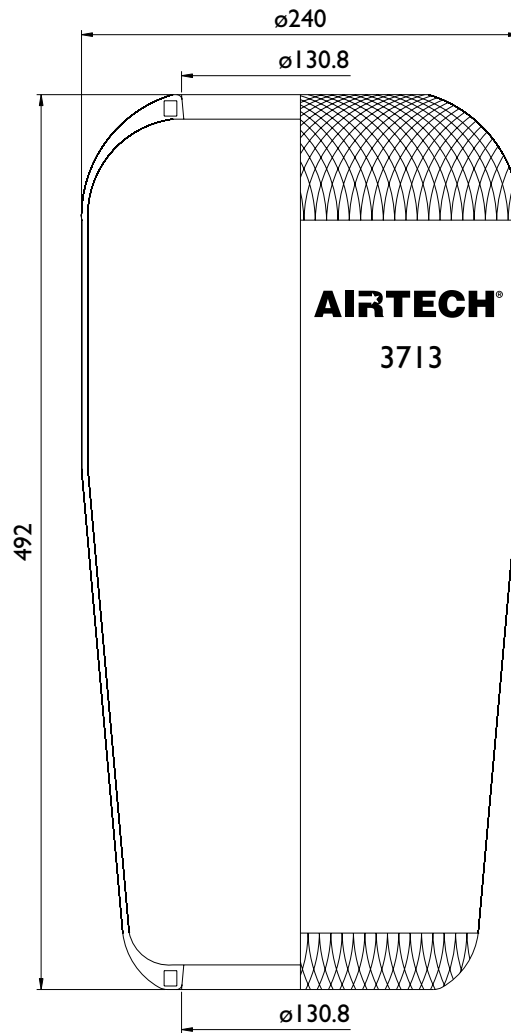

**Applicazioni principali**

VOLVO	1622116
VOLVO	6797169

**Lista corrispondenze**

CONTITECH	713 N
FIRESTONE	
PHOENIX	
TAURUS	
DUNLOP UK	
DUNLOP F	
GOODYEAR	
PIRELLI	
GART	

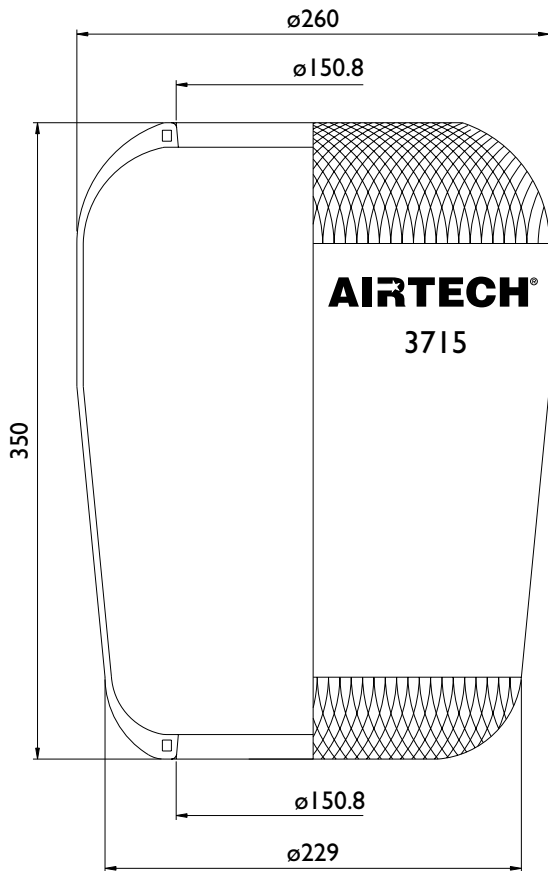

### Applicazioni principali

DAF	659561
DAF	683392
DAIMLER - CHRYSLER	A 363.229.00.01
DAIMLER - CHRYSLER	A 363.328.00.01
IVECO	4456111
MAGIRUS-DEUTZ	44561111
MAN	81.436.010.059
MAN	81.436.010.060
MAN	81.436.010.061
MAN	81.436.010.078
MAN	81.436.010.081
MAN	81.436.010.083
MAN	81.436.010.090
MAN	81.436.010.113
MAN	81.436.010.115
MAN	81.436.010.117
MAN BUS - serie 200	81.436.010.075
RVI	5.000.786.901
RVI	5.000.819.517

### Lista corrispondenze

CONTITECH	715 N
FIRESTONE	IRIC 335-310 / W01 095 0087
PHOENIX	IF 25
TAURUS	B 144
DUNLOP UK	PNP 304890101
DUNLOP F	
GOODYEAR	8015
PIRELLI	I SC 310-16 / 93518
GART	



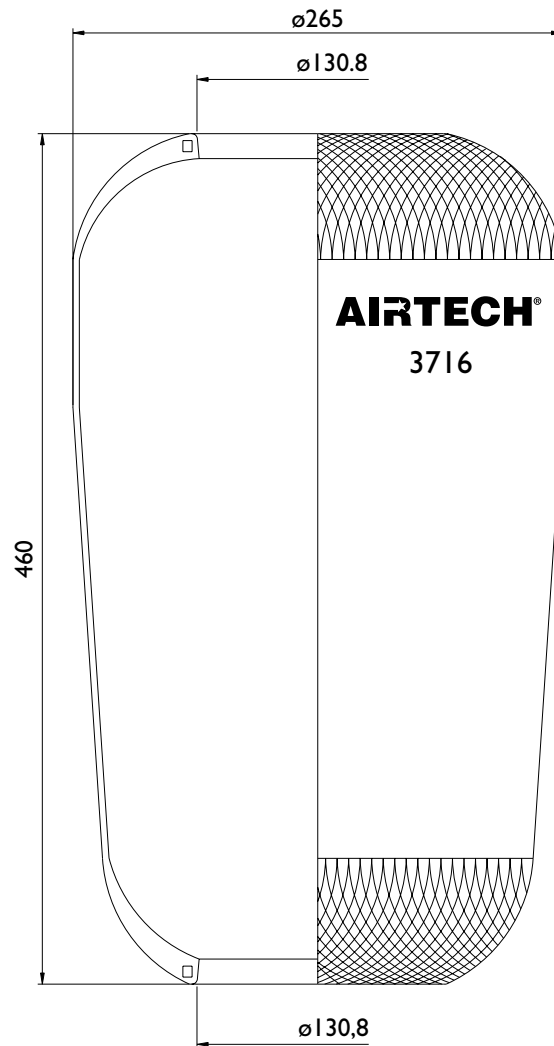

### Applicazioni principali

MAN	81.43601.0039
MAN	81.43601.0040
MAN	81.43601.6060
MAN	81.43601.6069
MAN	81.43601.6075
VOLVO	1593843

### Lista corrispondenze

CONTITECH	716 N
FIRESTONE	IR2A 450-305 / W01 095 0145
PHOENIX	IF 26B-1
TAURUS	B 197
DUNLOP UK	
DUNLOP F	
GOODYEAR	
PIRELLI	I SC 300-34 / 92548
GART	

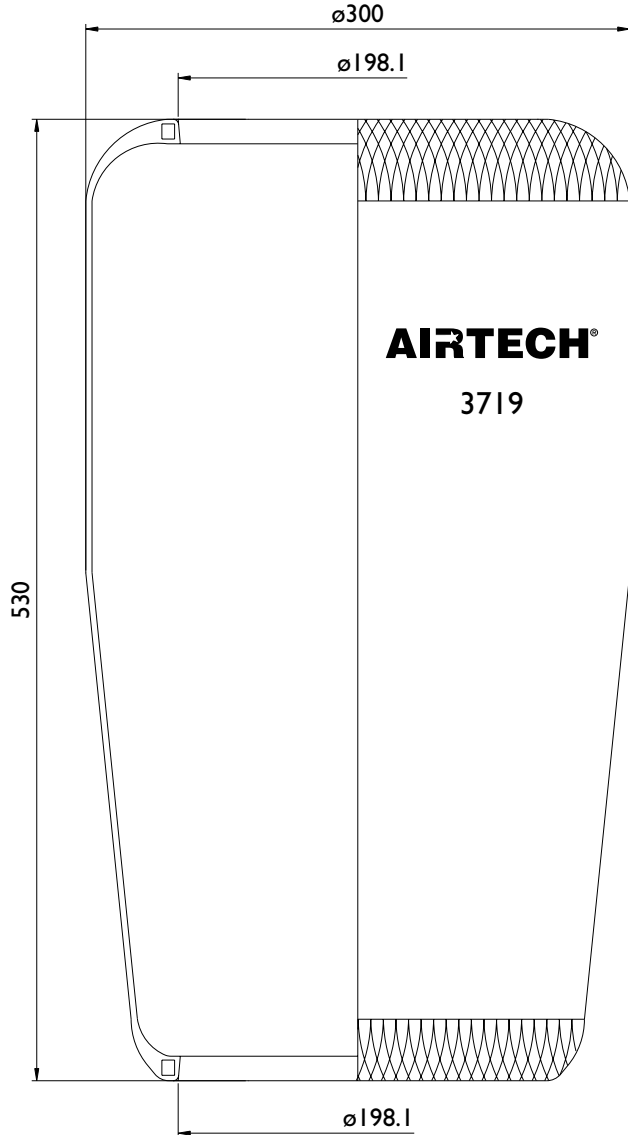

**Applicazioni principali**

BPW	02.2002.4000
BPW	05.42939.730
DAF	818225
EVO - BUS	4.731.032.000
GIGANT	196036
KOGEL	4.731.032.000
SCHMITZ	750215
NEOPLAN	1001.101.00
NEOPLAN	1021.002.00
KASSBOHRER	4.731.032.000

**Lista corrispondenze**

CONTITECH	719 N
FIRESTONE	1R2D 530-360 / W01 095 0192
PHOENIX	1F 32B
TAURUS	B 153
DUNLOP UK	PNP 304620101
DUNLOP F	
GOODYEAR	8118
PIRELLI	1 SC 360-43 / 92593
GART	

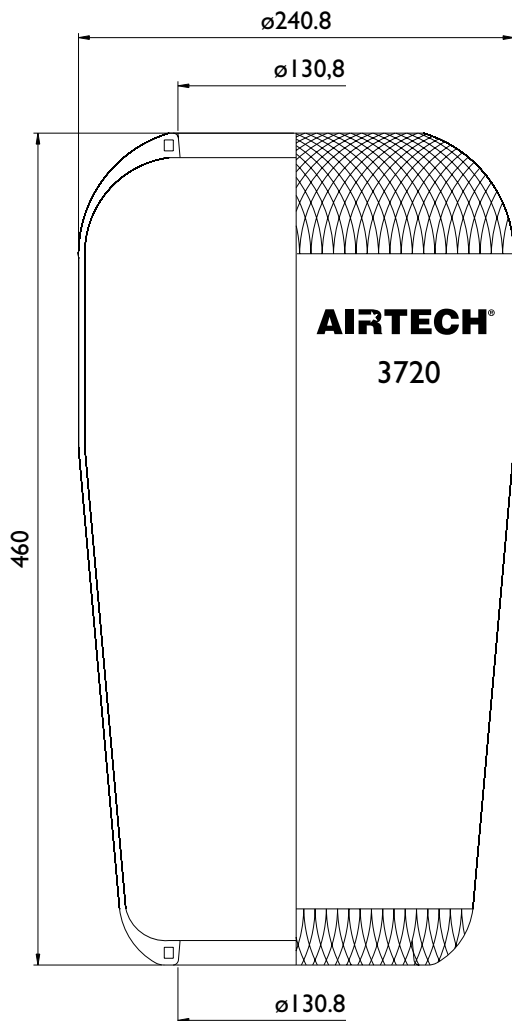

### Applicazioni principali

BPW	02.2002.41.00
DENNIS	650292
DENNIS	650298
DENNIS	650883
DENNIS	650884
DENNIS	650887
MAN	81.43601.0033
MAN	81.43601.0036
MAN	81.43601.0037
MAN	81.43601.0067
MAN	81.43601.0144
MERCEDES	307.328.0101
MERCEDES	360.328.0101
MERCEDES	363.328.0101
MERCEDES	387.328.0001
MERCEDES	387.328.0101
METRO-CAMMELL	X664 1056
NEOPLAN	1001.123.00
VOLVO	1622116
VOLVO	1629193

### Lista corrispondenze

CONTITECH	720 N
FIRESTONE	IR2A 460-295 / W01 095 0195
PHOENIX	IF 21
TAURUS	B 152
DUNLOP UK	PNP 301000100
DUNLOP F	D12 S04
GOODYEAR	9008
PIRELLI	I SC 290-30 / 88802
GART	

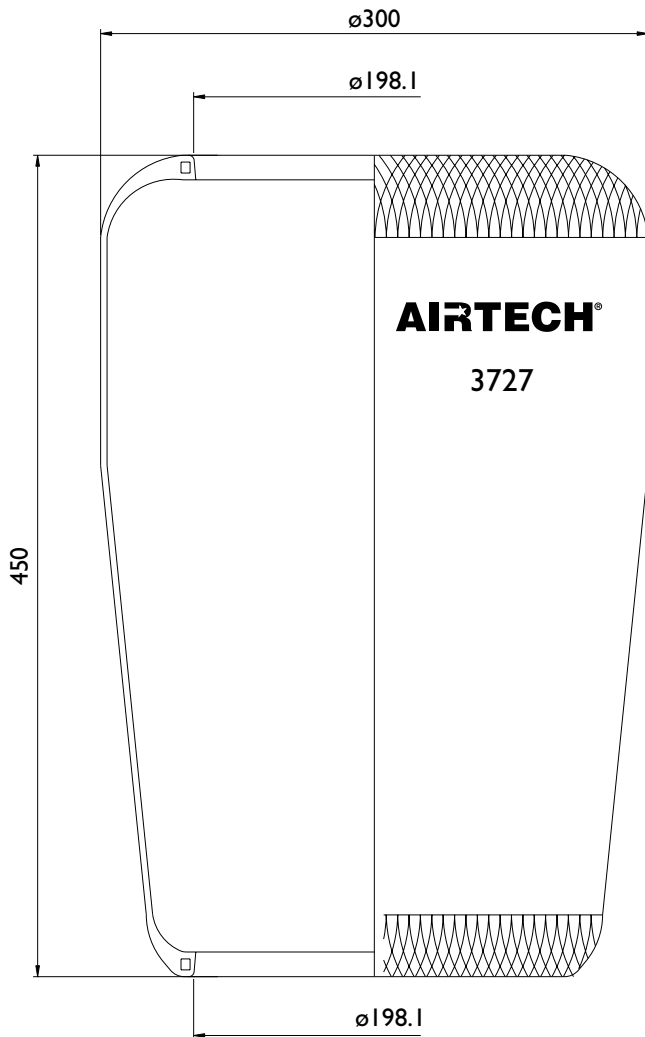

### Applicazioni principali

BPW	02.2002.4200
DAF BUS	638148
GIGANT	166226
MAN	81.43601.0056
MAN	81.43601.0057
MAN	81.43601.0058
MAN	81.43601.0079
MAN	81.43601.0082
MAN	81.43601.0084
MAN	81.43601.0091
MAN	81.43601.0114
MAN	81.43601.0116
MAN	81.43601.0118
MAN BUS	81.43601.0076
MERCEDES	307.328.0101
NEWAY	90557023
SCHMITZ	750212
VAN HOOL	624.319.640
VOLVO BUS	1134446

### Lista corrispondenze

CONTITECH	727 N
FIRESTONE	1R2D 460-360 / W01 095 0191
PHOENIX	1F 32A
TAURUS	B 149
DUNLOP UK	PNP 306420100
DUNLOP F	
GOODYEAR	8117
PIRELLI	1 SC 360-34 / 92575
GART	

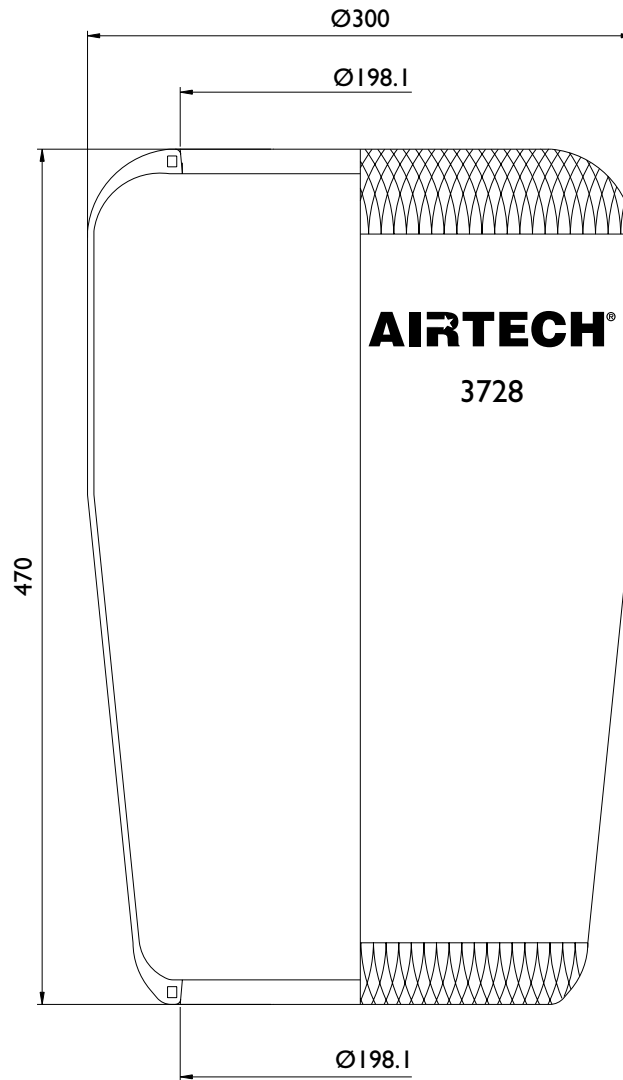

### Applicazioni principali

DAF BUS	638148
MAN BUS	81.43601.0076
SCHMITZ	750212
VOLVO BUS	1134446

### Lista corrispondenze

CONTITECH	728 N
FIRESTONE	IR2D 470-360 / W01 095 0419
PHOENIX	IF 32A-2
TAURUS	B 149
DUNLOP UK	PNP 306420100
DUNLOP F	
GOODYEAR	8717
PIRELLI	ISC 360-34 / 92575
GART	

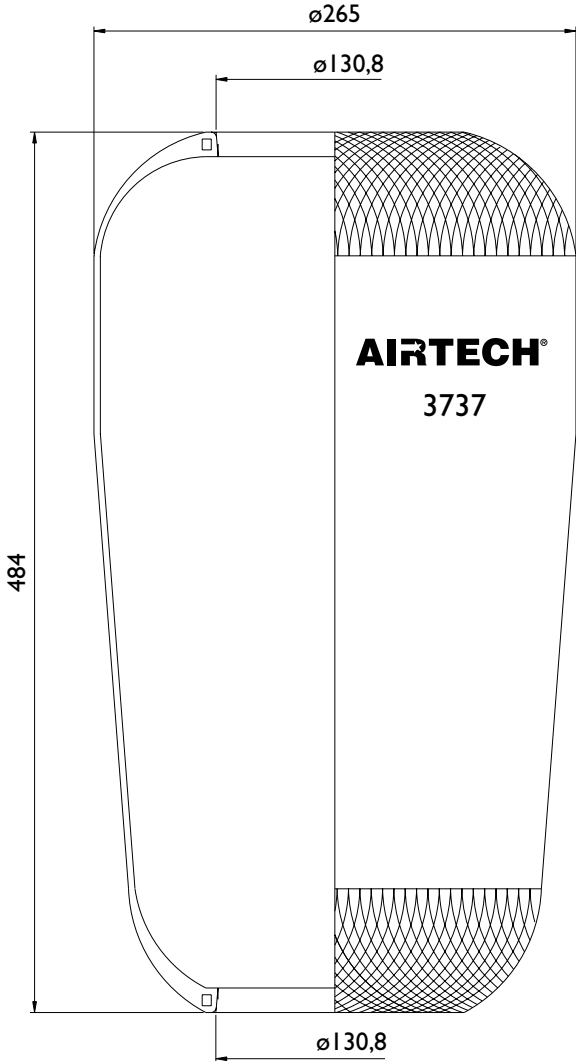

**Applicazioni principali**

DAIMLER CHRYSLER	393.328.0101
IVECO	474 67 40
MENARINI	178739

**Lista corrispondenze**

CONTITECH	737 N
FIRESTONE	1R2A 480-330 / W01 095 021 I
PHOENIX	1F 26
TAURUS	B 127
DUNLOP UK	
DUNLOP F	
GOODYEAR	
PIRELLI	I S 323-23 / 89756
GART	

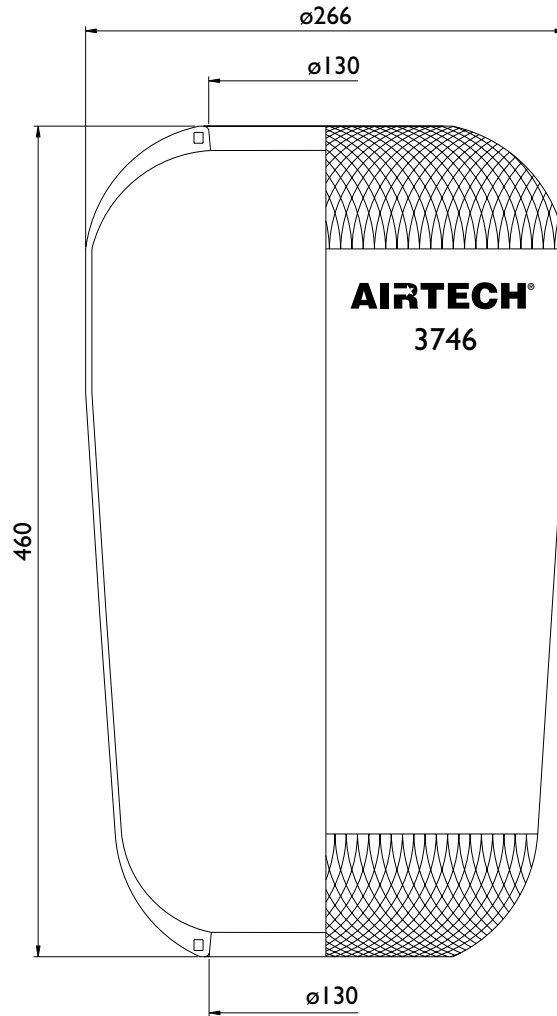

**Applicazioni principali**

DAIMLER CHRYSLER	318.328.0001

**Lista corrispondenze**

CONTITECH	746 N
FIRESTONE	
PHOENIX	
TAURUS	
DUNLOP UK	
DUNLOP F	
GOODYEAR	
PIRELLI	
GART	

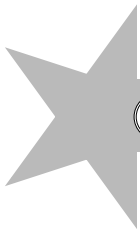

**A520077**

**MEMBRANE**

**AIRTECH® 3757**

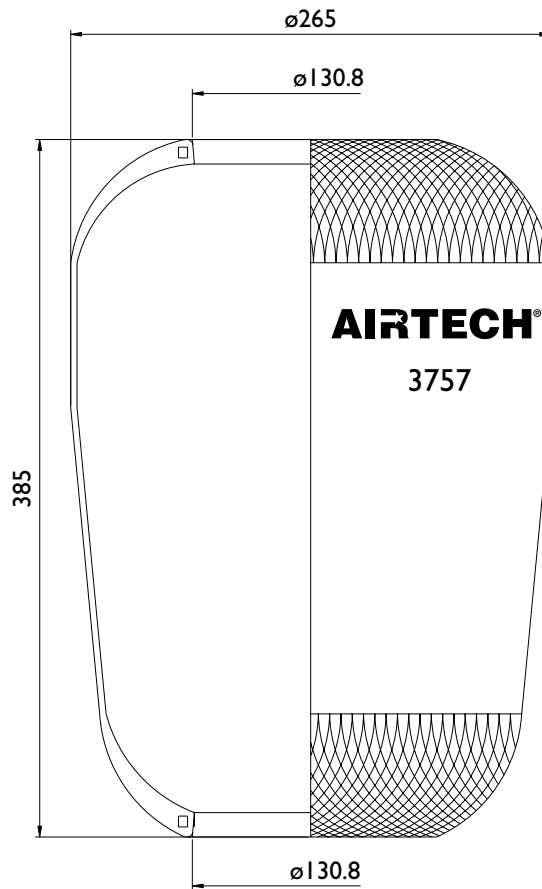

**Applicazioni principali**

DAIMLER CHRYSLER	363.328.0201

**Lista corrispondenze**

CONTITECH	757 N
FIRESTONE	1R2A 380-305 / W01 095 0212
PHOENIX	1F 26C
TAURUS	B 126
DUNLOP UK	
DUNLOP F	
GOODYEAR	
PIRELLI	
GART	



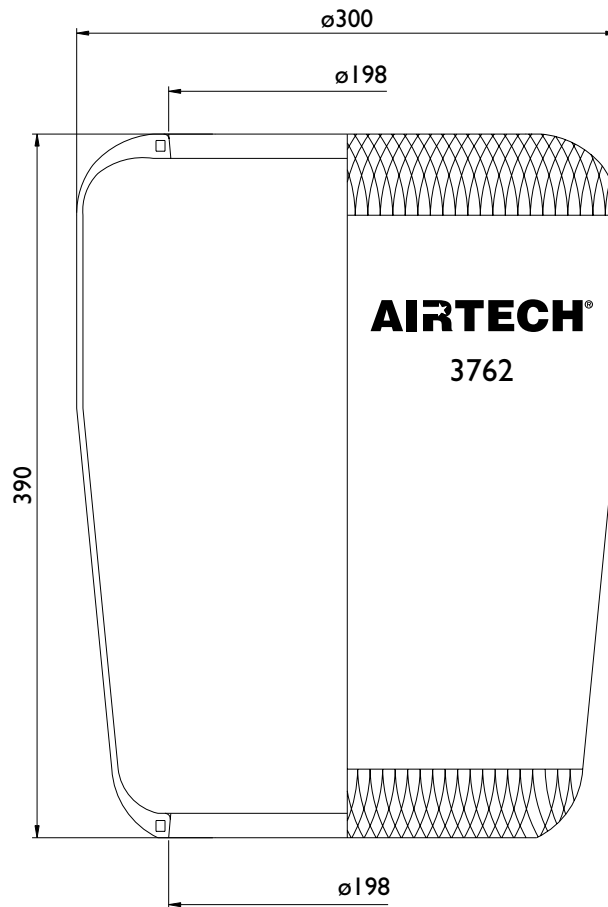

### Applicazioni principali

BPW	02.2002.4200
DAF	0578361
DAF	664425
EVO-BUS	4.731.013.000
GIGANT	196035
KASSBOHRER	4.731.013.000
MAN	81.43601.0049
MAN	81.43601.0052
MERCEDES	382.327.7101
NEOPLAN - Auwärter	1021.003.00
VAN HOOL BUS A120	624319640

### Lista corrispondenze

CONTITECH	762 N
FIRESTONE	IR2D 390-360 / W01 095 0190
PHOENIX	IF 32
TAURUS	BL 143
DUNLOP UK	PNP 307800100
DUNLOP F	
GOODYEAR	9010
PIRELLI	I SC 360-30 / 92594
GART	

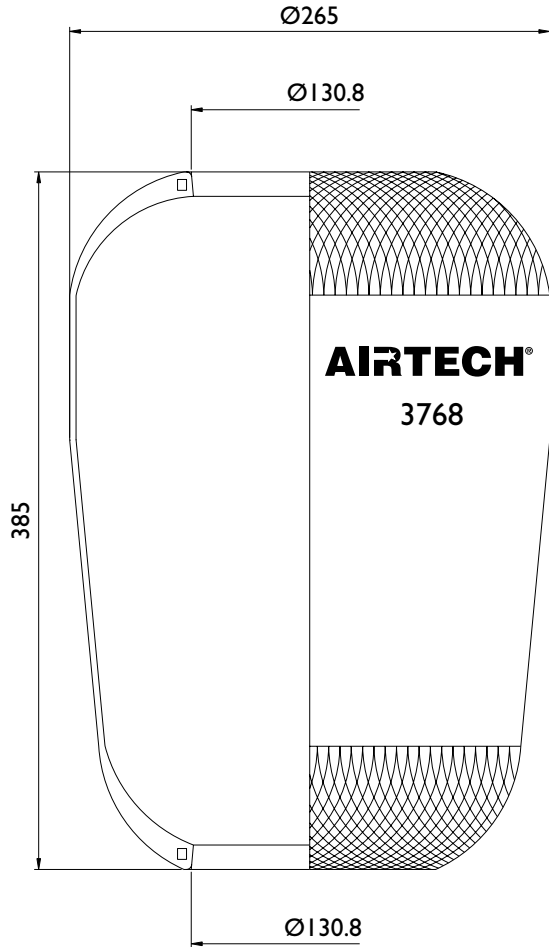

**Applicazioni principali**

RVI	5.000.9455.176
SCANIA	1612465
VOLVO	1612455
VOLVO	660252

**Lista corrispondenze**

CONTITECH	768 N
FIRESTONE	1R2A 380-330 / W01 095 0213
PHOENIX	I E27
TAURUS	B 125
DUNLOP UK	
DUNLOP F	
GOODYEAR	
PIRELLI	
GART	

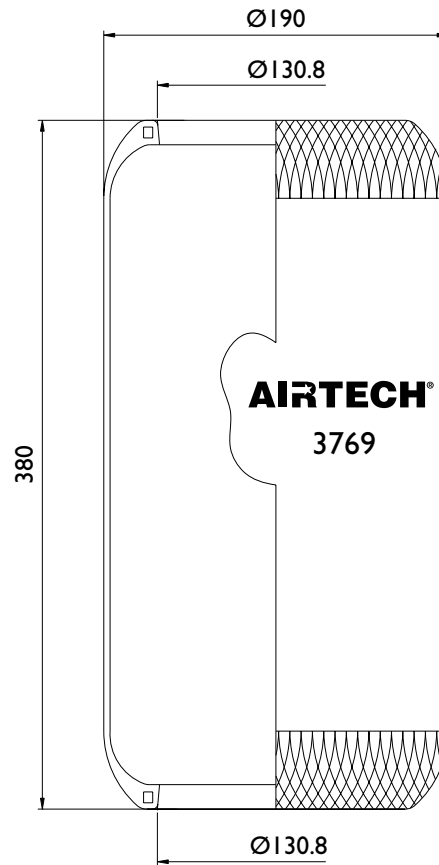

### Applicazioni principali

MAN	81.43601.0017
MENARINI	252933
RVI	5.000.786.641
RVI	5.000.805.284
VAN HOOL	624319-710

### Lista corrispondenze

CONTITECH	769 N
FIRESTONE	IRIA 380-260 / W01 095 0204
PHOENIX	IE 18
TAURUS	B 156
DUNLOP UK	PNP 301470101
DUNLOP F	D10 S02
GOODYEAR	8053
PIRELLI	
GART	

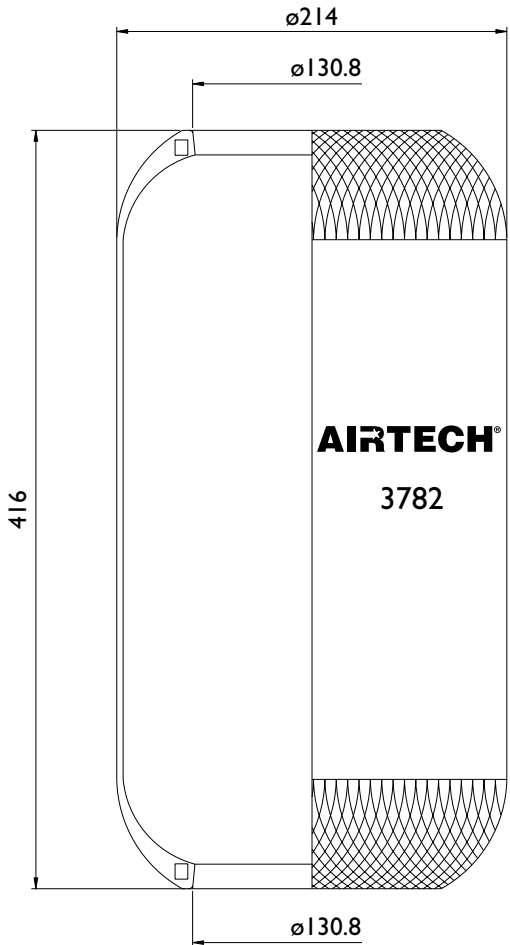

**Applicazioni principali**

IVECO - FIAT	8188539
MENARINI	178741
MERCEDES	382.327.7201
RVI	5.000.787.632
RVI	5.000.954.176

**Lista corrispondenze**

CONTITECH	782 N
FIRESTONE	IRIA 415-285 / W01 095 0197
PHOENIX	I E21D
TAURUS	B 124
DUNLOP UK	
DUNLOP F	
GOODYEAR	9013
PIRELLI	I S 270-25C / 97608
GART	D290 290.0.420

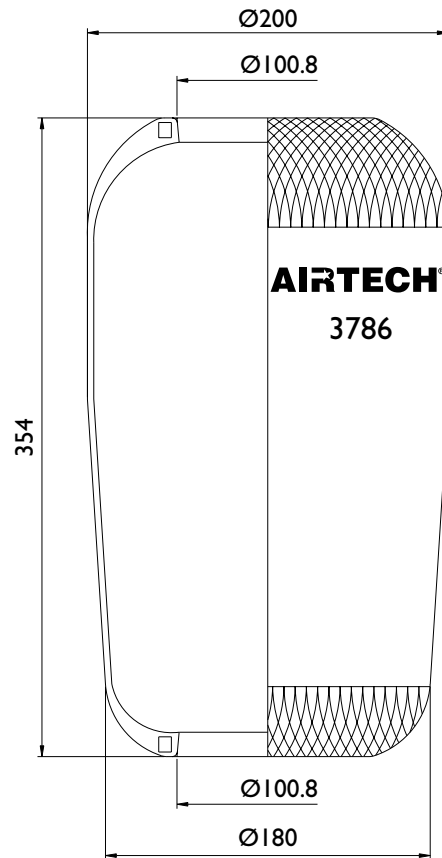

**Applicazioni principali**

MAN	81.43601.0053

**Lista corrispondenze**

CONTITECH	786 N
FIRESTONE	
PHOENIX	I F14
TAURUS	B 102
DUNLOP UK	
DUNLOP F	
GOODYEAR	
PIRELLI	
GART	

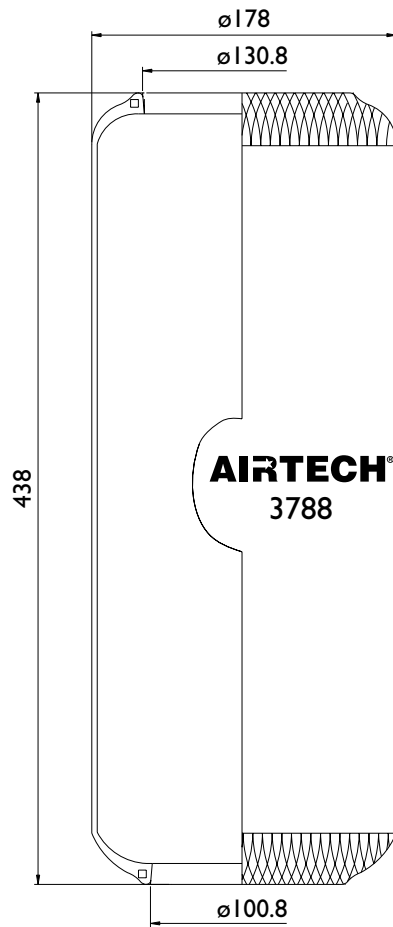
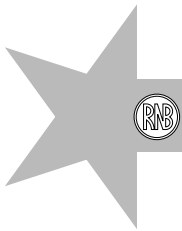

**Applicazioni principali**

NEOPLAN	1001.121.00
VOLVO	6782726

**Lista corrispondenze**

CONTITECH	788 N
FIRESTONE	
PHOENIX	
TAURUS	B 155
DUNLOP UK	
DUNLOP F	
GOODYEAR	
PIRELLI	
GART	

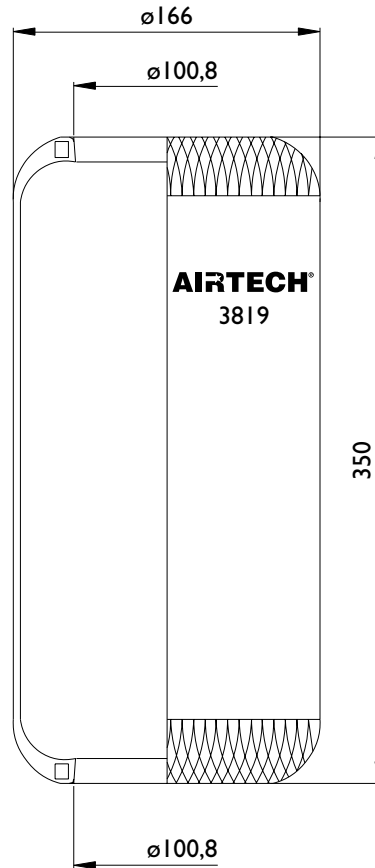

**Applicazioni principali**

BREDA MENARINI BUS	192709
DAIMLER-CHRYSLER	
IVECO BUS	98445471
IVECO EUROCARGO	500301776

**Lista corrispondenze**

CONTITECH	
FIRESTONE	
PHOENIX	
TAURUS	
DUNLOP UK	
DUNLOP F	
GOODYEAR	
PIRELLI	I S 215-22-90609 (H340) IS 215-23-202189 (H360)
GART	296/C 296.0.360



Entrata aria



Perno combinato



**A520111**

**MEMBRANE**

**AIRTECH® 3838**



**Applicazioni principali**

DAIMLER CHRYSLER	674.328.0001

**Lista corrispondenze**

CONTITECH	838 N
FIRESTONE	
PHOENIX	IF 26D
TAURUS	
DUNLOP UK	
DUNLOP F	
GOODYEAR	
PIRELLI	
GART	



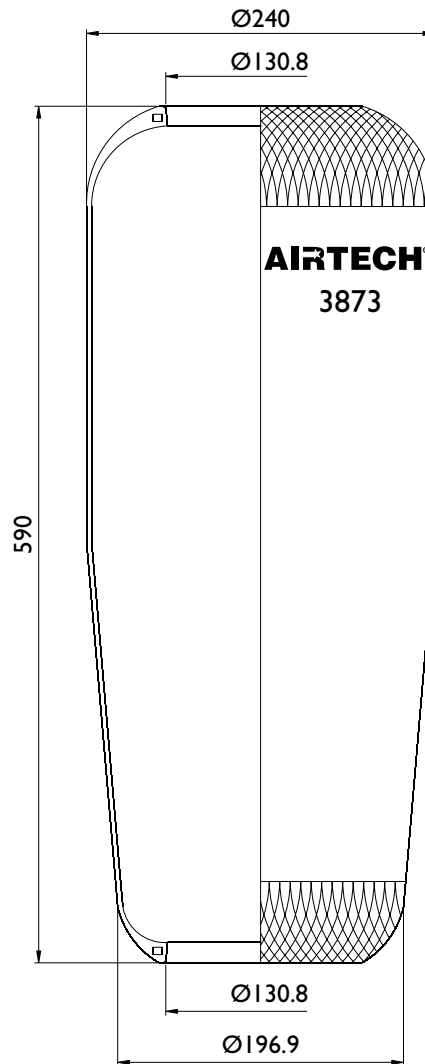

**Applicazioni principali**

IKARUS	190.02
MERCEDES	674.328.0201

**Lista corrispondenze**

CONTITECH	873 N
FIRESTONE	
PHOENIX	
TAURUS	
DUNLOP UK	
DUNLOP F	
GOODYEAR	
PIRELLI	
GART	

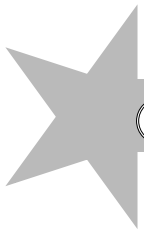

**A520101**

**MEMBRANE**

**AIRTECH® 3876**

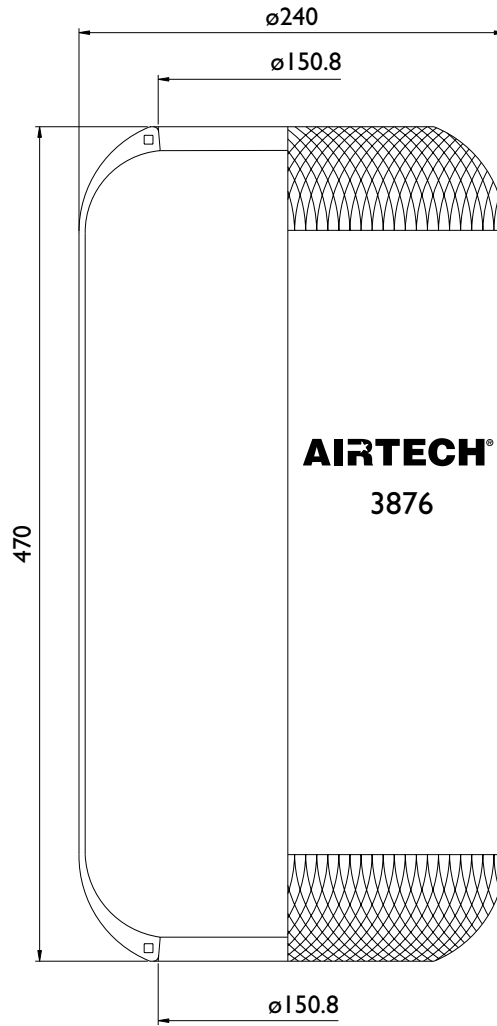

**Applicazioni principali**

IVECO	8139068
RVI	5.000.296.816

**Lista corrispondenze**

CONTITECH	876 N
FIRESTONE	
PHOENIX	
TAURUS	
DUNLOP UK	
DUNLOP F	
GOODYEAR	8314
PIRELLI	I S 323-34 / 92477
GART	D298C 298.0.460

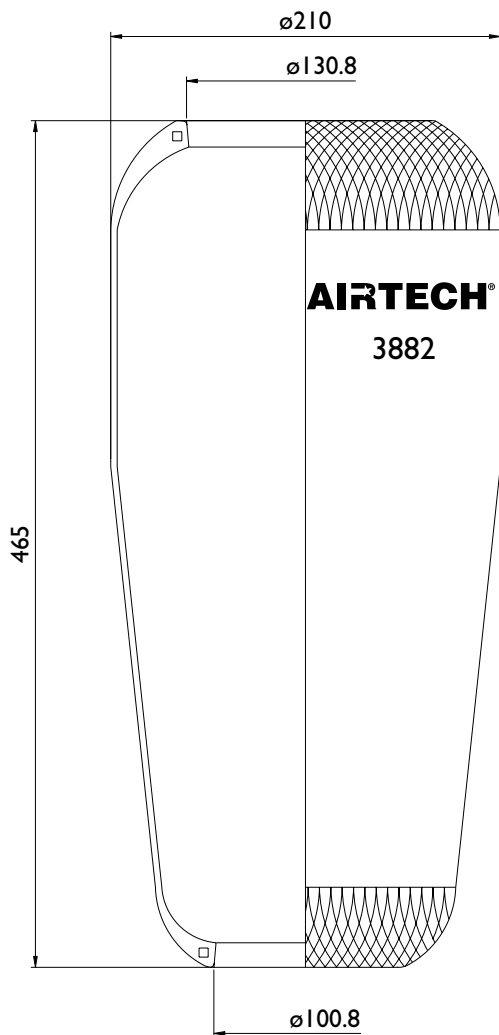

### Applicazioni principali

DAIMLER CHRYSLER	A 699.328.0101
MAN	81.43601.0032
MAN	81.43601.0065
MAN	81.43601.0067
MAN	81.43601.0070
MAN	81.43601.0092
MAN	81.43601.0093
MAN	81.43601.0094
MAN	81.43601.0100
MAN	81.43601.0103
MAN	81.43601.0121
MAN F90 - M90	81.43601.0099
MENARINI BUS 240	D031105

### Lista corrispondenze

CONTITECH	882 NI
FIRESTONE	
PHOENIX	IF 16
TAURUS	B 155
DUNLOP UK	
DUNLOP F	
GOODYEAR	
PIRELLI	ISC250 - 28 / 97042
GART	

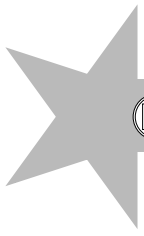

**A520096**

**MEMBRANE**

**AIRTECH® 3883**

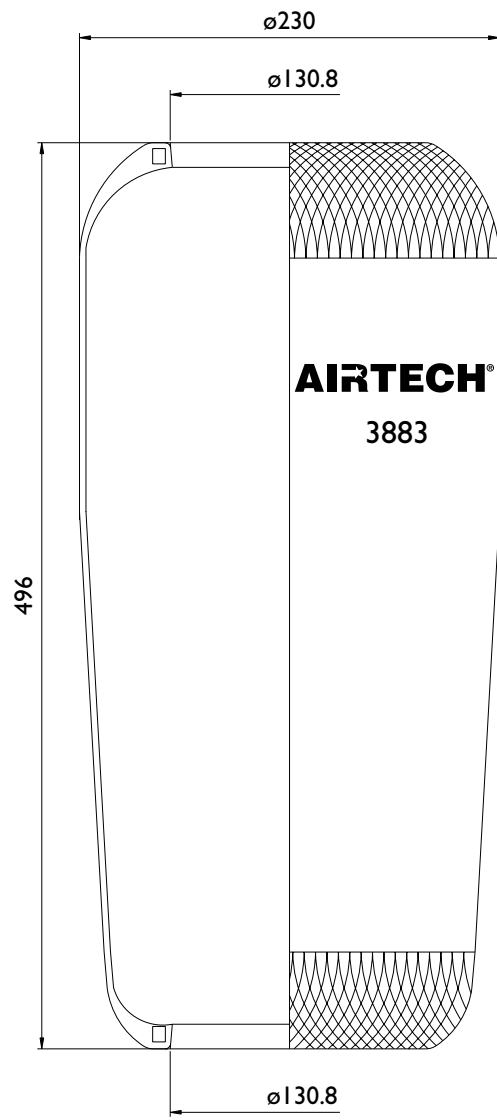

**Applicazioni principali**

MAN	81.43601.0071
MAN	81.43601.0072
MAN	81.43601.0110
MAN	81.43601.0128
VOLVO	1082085

**Lista corrispondenze**

CONTITECH	883 N1
FIRESTONE	
PHOENIX	1F 21C2
TAURUS	
DUNLOP UK	
DUNLOP F	
GOODYEAR	9012
PIRELLI	
GART	

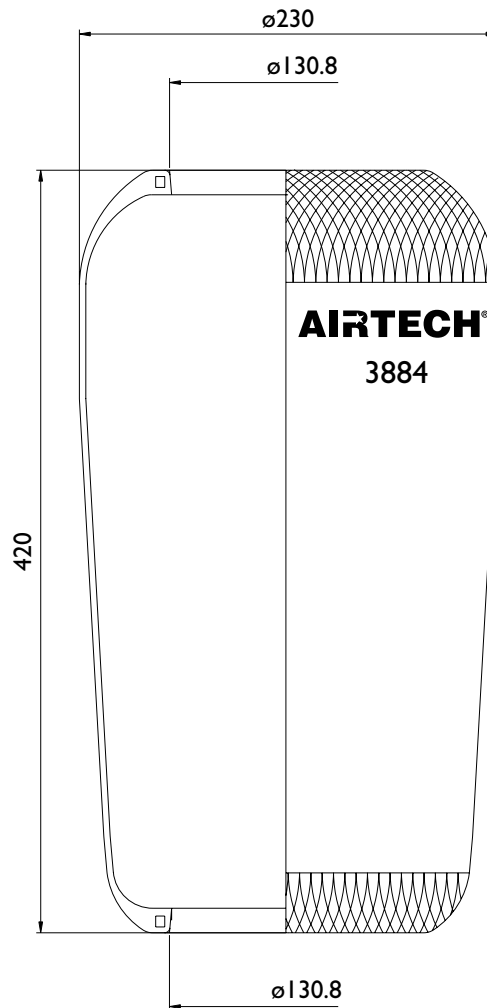

### Applicazioni principali

DAIMLER CHRYSLER	658.328.0001
IVECO	5.003.014.52
IVECO	8188539
MAN	81.43601.0066
MAN	81.43601.0068
MAN	81.43601.0069
MAN	81.43601.0106
MAN	81.43601.0108
RVI	5.010.294.385

### Lista corrispondenze

CONTITECH	884 N
FIRESTONE	
PHOENIX	IF 20A
TAURUS	BL 249
DUNLOP UK	
DUNLOP F	
GOODYEAR	9002
PIRELLI	I SC 270-28 / 97043
GART	

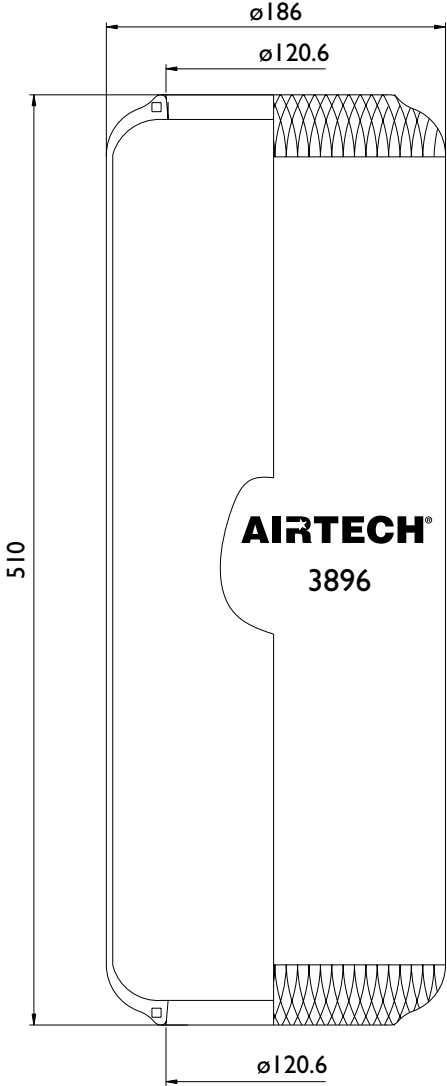

**Applicazioni principali**

SCANIA	411627

**Lista corrispondenze**

CONTITECH	896 N
FIRESTONE	1R1J 520-285FF/W01 095 0245
PHOENIX	2E 18A
TAURUS	B 166
DUNLOP UK	PNP 305140100
DUNLOP F	
GOODYEAR	8040
PIRELLI	
GART	

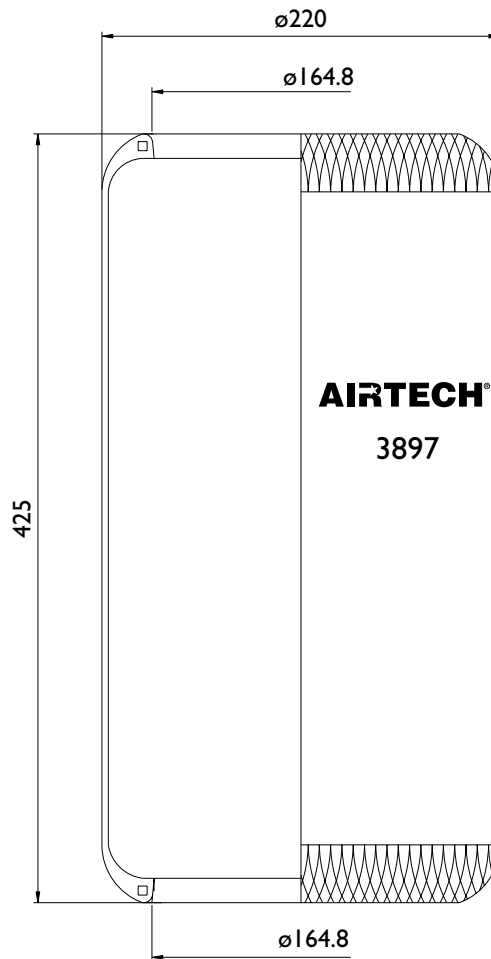

### Applicazioni principali

IVECO	795097
PEGASO	794686
PEGASO	795097
SCANIA	0411622
SCANIA	0411623
SCANIA+SCANIA BUSSAR	402315

### Lista corrispondenze

CONTITECH	897 N
FIRESTONE	IRIK 440-320FF/W01 095 0229
PHOENIX	2E 23
TAURUS	B 165
DUNLOP UK	PNP 305210101
DUNLOP F	
GOODYEAR	8028
PIRELLI	I S 320-30 / 88788
GART	D278 278.0.430

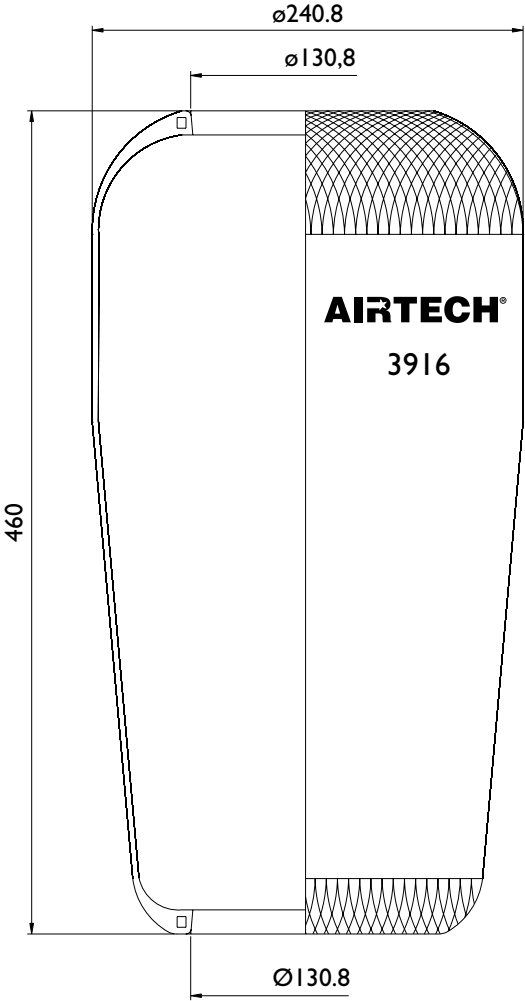

**Applicazioni principali**

MAN	81.43601.0095
MAN	81.43601.0097
MAN	81.43601.0102
MAN	81.43601.0105
MAN	81.43601.0126
MAN	81.43601.0138
VOLVO	1159842

**Lista corrispondenze**

CONTITECH	916 N1
FIRESTONE	
PHOENIX	IF 21C-5
TAURUS	B 154
DUNLOP UK	
DUNLOP F	D12 S05
GOODYEAR	9015
PIRELLI	
GART	



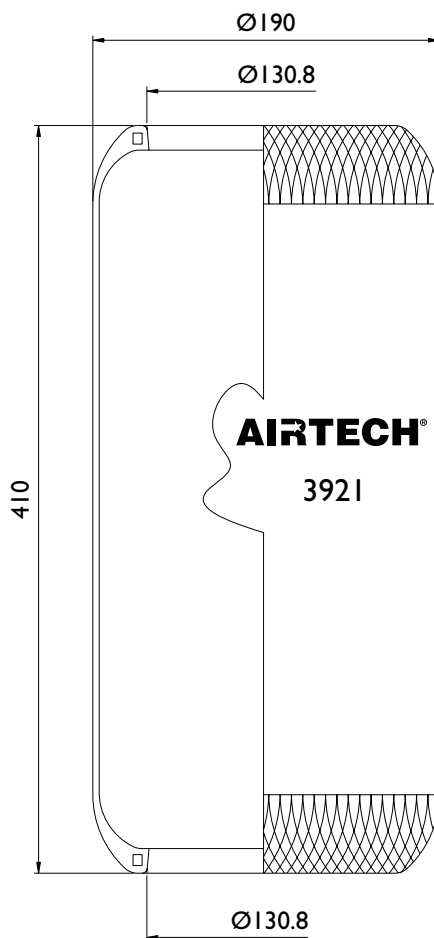

## Applicazioni principali

RVI	5.000.288.982

## Lista corrispondenze

CONTITECH	921 N
FIRESTONE	IRIA 415-260 / W01 095 0226
PHOENIX	IE 17
TAURUS	B160
DUNLOP UK	
DUNLOP F	D10 S04
GOODYEAR	8043
PIRELLI	I S 285-23
GART	



**A520033**

**MEMBRANE**

**AIRTECH® 3927**

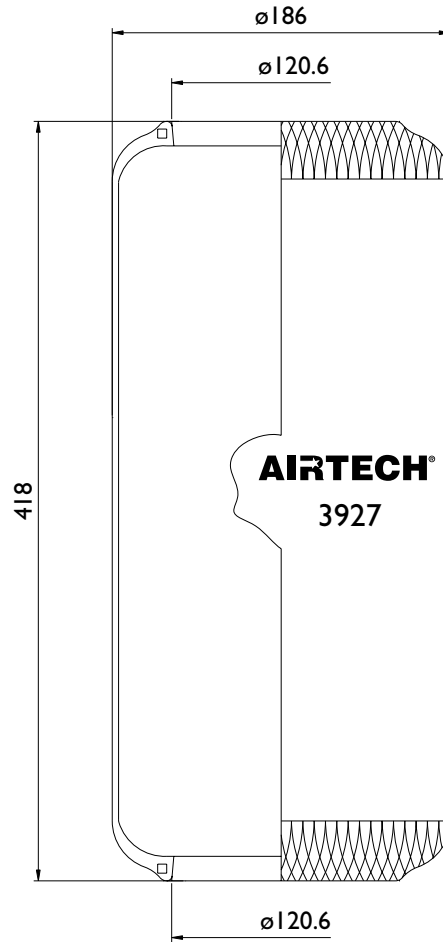

### Applicazioni principali

DENNIS	611812
DENNIS	611896
SCANIA	10.904.403
SCANIA	934094
SCANIA BUS	434932
SCANIA-K113-K82-112-L113	10904403
VOLVO	3116354
VOLVO	AAU2542

### Lista corrispondenze

CONTITECH	927 N
FIRESTONE	1R1K380-280/W01 095 0244
PHOENIX	2E 18B
TAURUS	B 179
DUNLOP UK	PNP 300080100
DUNLOP F	
GOODYEAR	8037
PIRELLI	
GART	

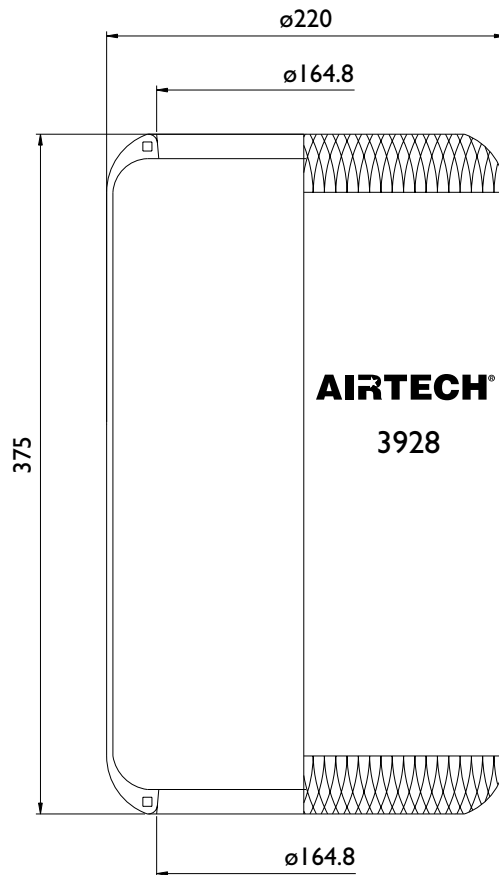

**Applicazioni principali**

IVECO	645 3741
LEYLAND	10.904.403
SCANIA	434 932
VOLVO	3116983

**Lista corrispondenze**

CONTITECH	928 N
FIRESTONE	IRIK 380-320FF/W01 095 0228
PHOENIX	2E 23A
TAURUS	B 178
DUNLOP UK	IC 3308
DUNLOP F	D12 S03
GOODYEAR	8042
PIRELLI	
GART	

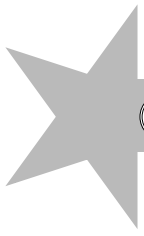

**A520150**

**MEMBRANE**

**AIRTECH® 3936**

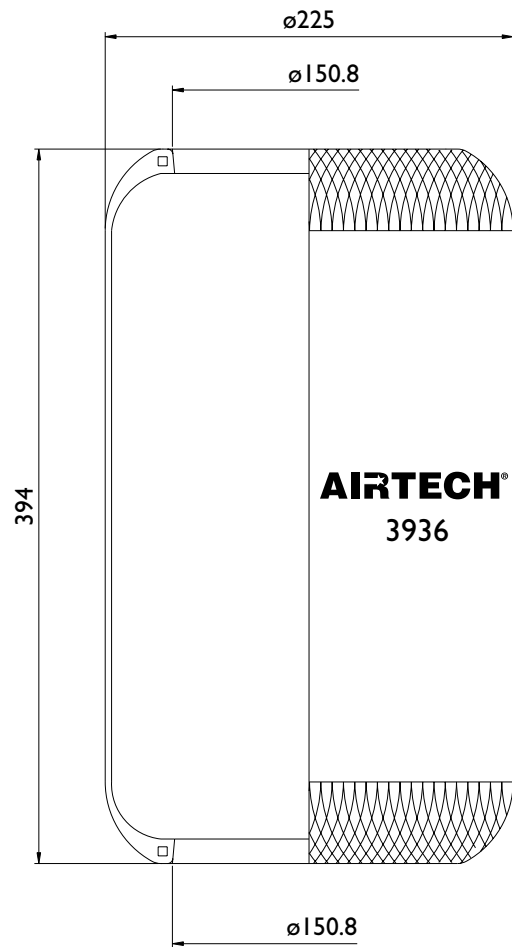

**Applicazioni principali**

RVI	5.000.819.370

**Lista corrispondenze**

CONTITECH	936 N
FIRESTONE	
PHOENIX	
TAURUS	
DUNLOP UK	PNP 309070100
DUNLOP F	D12 S01
GOODYEAR	
PIRELLI	
GART	

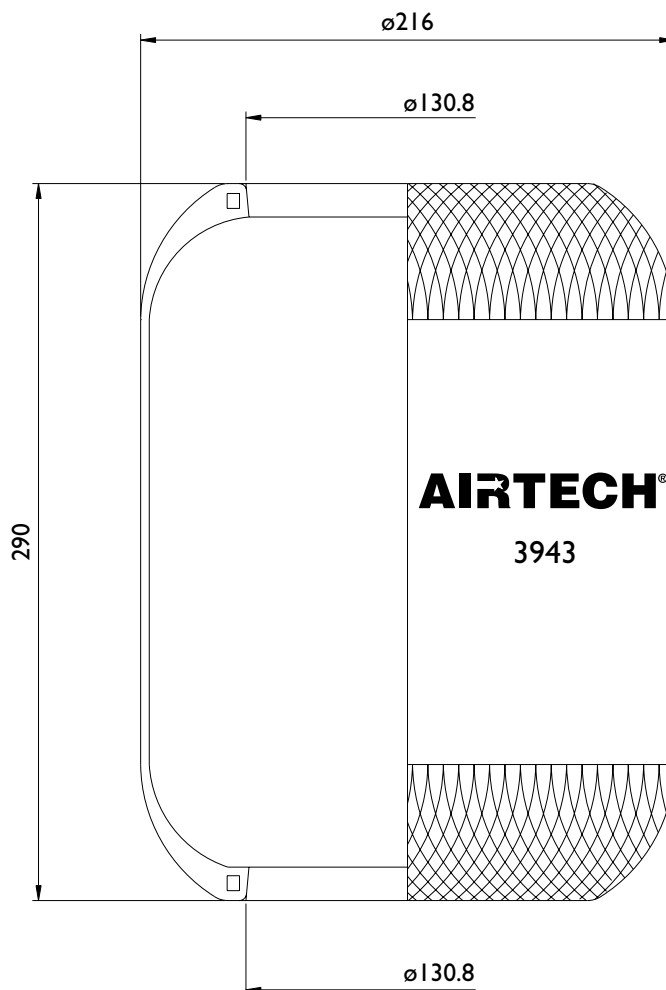

### Applicazioni principali

INBUS	5001051
IVECO	6144040
IVECO	8160165

### Lista corrispondenze

CONTITECH	943 N
FIRESTONE	IRIA 260-285 / W01 095 0189
PHOENIX	
TAURUS	B 194
DUNLOP UK	PNP 316720100
DUNLOP F	
GOODYEAR	9001
PIRELLI	I S 285-18 / 88809
GART	D276/D 276.0.260

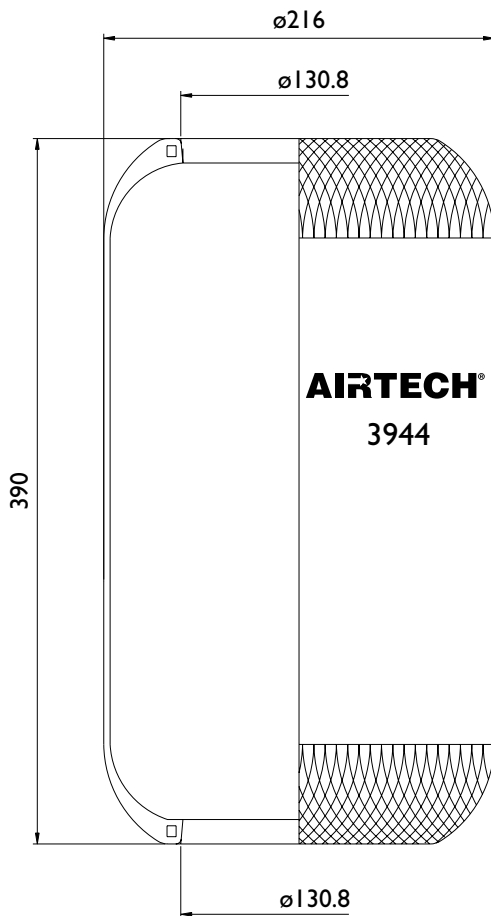

### Applicazioni principali

DAF	8627584
INBUS	4.840.001
INBUS	4.840.005
INBUS	4.890.001
INBUS 330	5001098
IVECO	4714019
IVECO	4714025
IVECO	4722525
IVECO	4735768
IVECO	4736728
IVECO	4738008
IVECO	6657150
IVECO	8188526
IVECO	97108021
IVECO	99459166
MENARINI	325993
MENARINI 201	178623
PORTESI	700176
SCANIA BUS	523229

### Lista corrispondenze

CONTITECH	944 N
FIRESTONE	IRIB 390-270 / W01 095 0121
PHOENIX	
TAURUS	
DUNLOP UK	
DUNLOP F	
GOODYEAR	8012
PIRELLI	I S 270-23 / 97619
GART	D290B 290.0.390

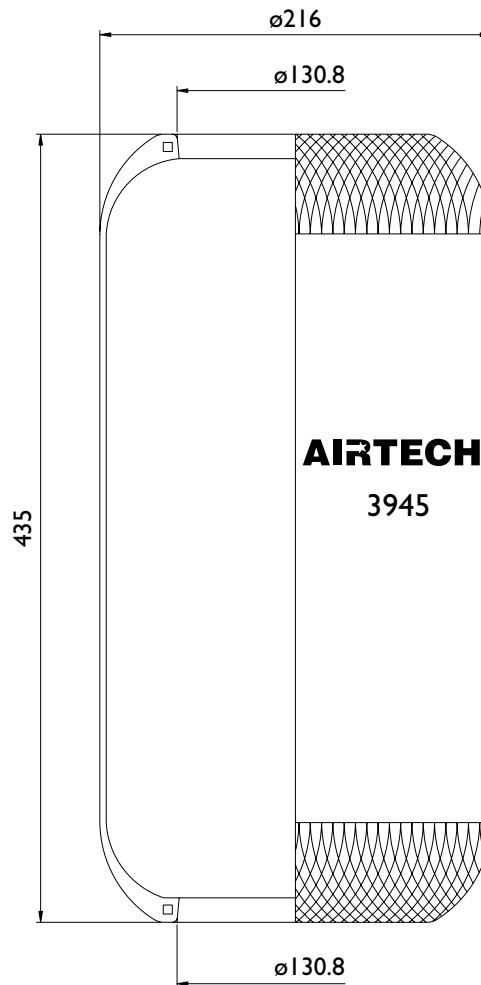

**Applicazioni principali**

IVECO BUS 370 / 380	4716989
MENARINI BUS	178741

**Lista corrispondenze**

CONTITECH	945 N
FIRESTONE	IRIA 460-290 / W01 095 0063
PHOENIX	IE 21C
TAURUS	B124
DUNLOP UK	PNP 301000101
DUNLOP F	D11 S02
GOODYEAR	9014
PIRELLI	I S 285-25 / 97555
GART	D276 276.0.420

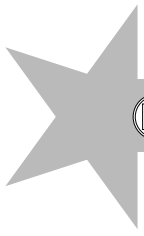

**A520116**

**MEMBRANE**

**AIRTECH® 31234**

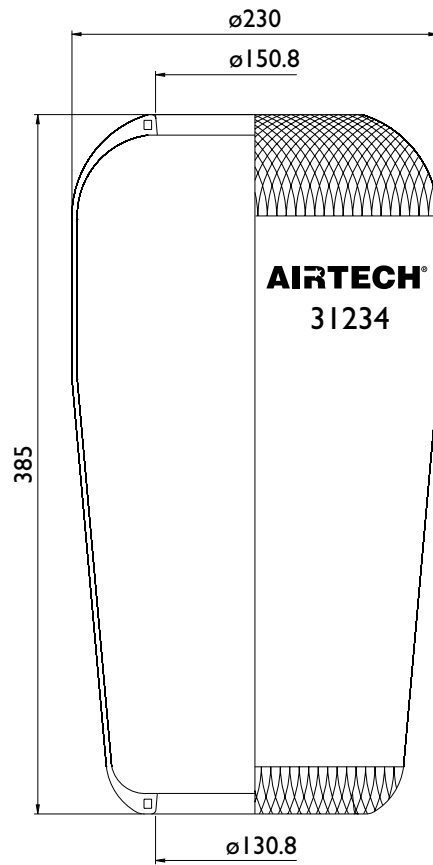

**Applicazioni principali**

RVI	5.000.831.423
VOLVO	8147475

**Lista corrispondenze**

CONTITECH	1234 N
FIRESTONE	
PHOENIX	
TAURUS	
DUNLOP UK	
DUNLOP F	
GOODYEAR	
PIRELLI	
GART	



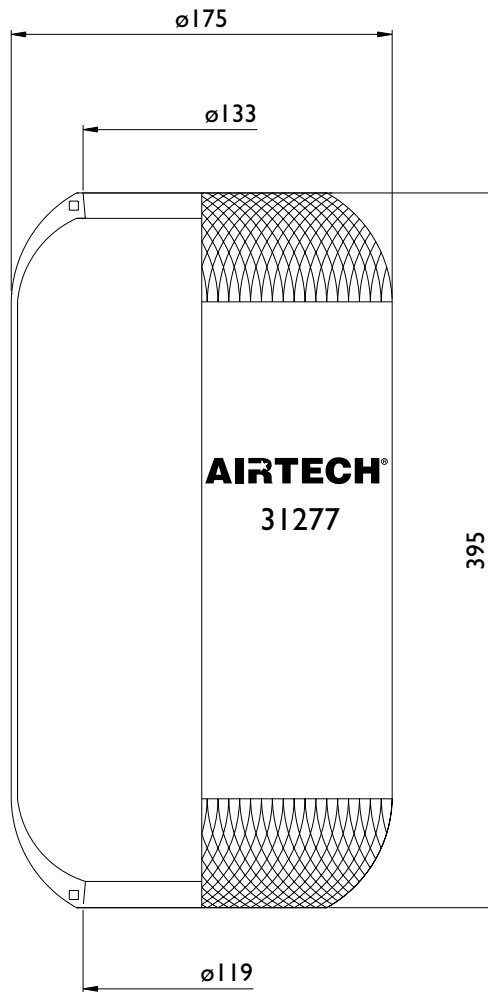

**Applicazioni principali**

VOLVO B10L	3.111.277
VOLVO	3.112.775.291

**Lista corrispondenze**

CONTITECH	
FIRESTONE	IR4U 395260 / W01 095 0453
PHOENIX	
TAURUS	
DUNLOP UK	PNP31095
DUNLOP F	
GOODYEAR	
PIRELLI	
GART	

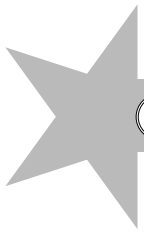

**A520092**

**MEMBRANE**

**AIRTECH® 31421**

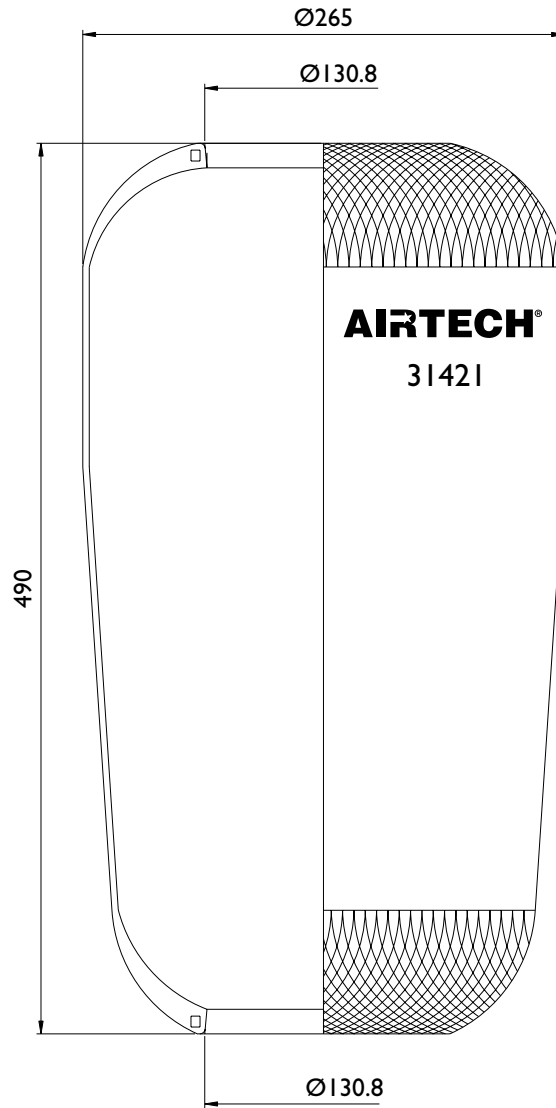

**Applicazioni principali**

VOLVO	1075290
VOLVO	1622115

**Lista corrispondenze**

CONTITECH	1421 N
FIRESTONE	
PHOENIX	
TAURUS	
DUNLOP UK	
DUNLOP F	
GOODYEAR	
PIRELLI	
GART	

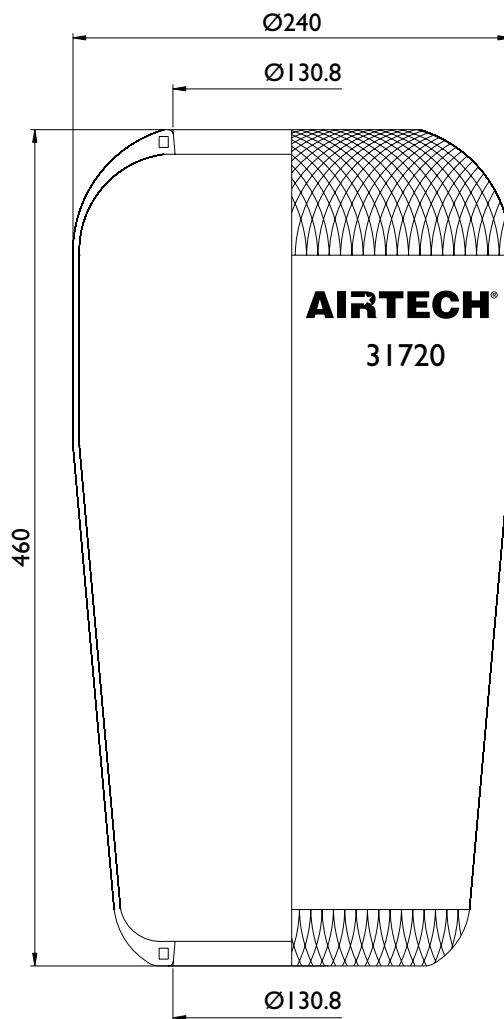

### Applicazioni principali

DAIMLER CHRYSLER	655.327.0001

### Lista corrispondenze

CONTITECH	1720 N
FIRESTONE	
PHOENIX	
TAURUS	
DUNLOP UK	
DUNLOP F	
GOODYEAR	
PIRELLI	
GART	

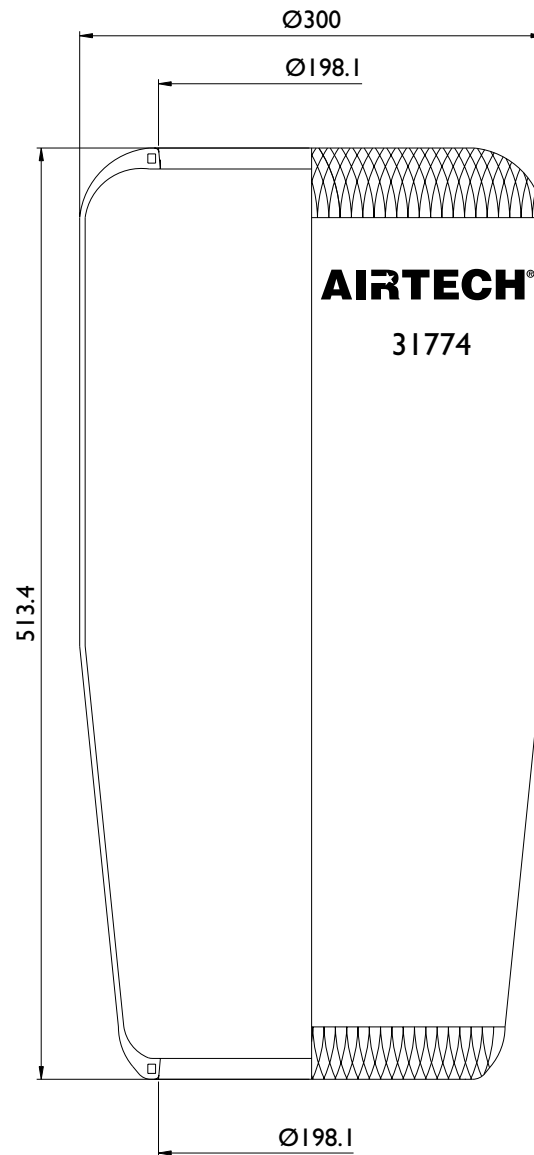
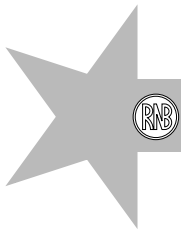

**Applicazioni principali**

BPW	02.2002.4300
GIGANT	196039
KÖGEL	4.731.038.000
SCHMITZ	750225

**Lista corrispondenze**

CONTITECH	1774 N
FIRESTONE	
PHOENIX	
TAURUS	
DUNLOP UK	
DUNLOP F	
GOODYEAR	
PIRELLI	
GART	

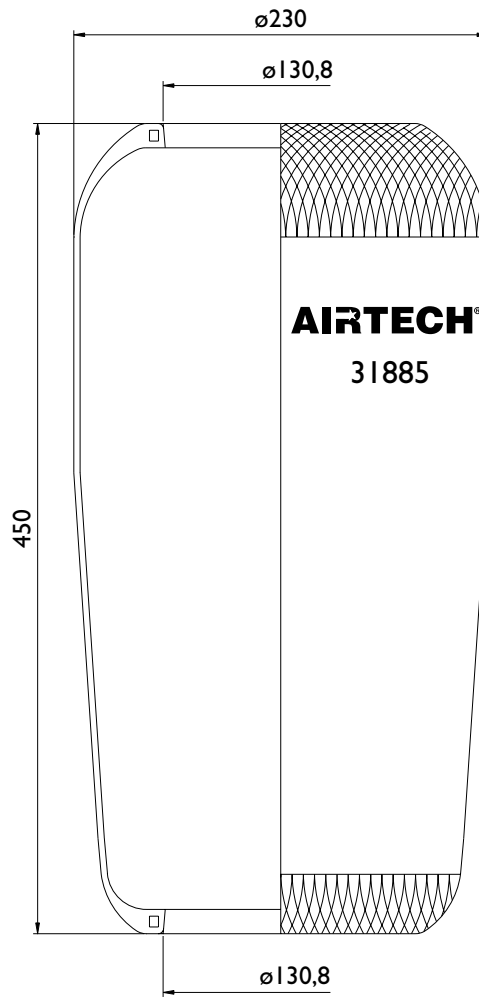

**Applicazioni principali**

IVECO	9.847.8799
MAN	81.43601.0104
MAN	81.43601.0109
MAN	81.43601.0111
MAN	81.43601.0120
MAN	81.43601.0125
MAN	81.43601.0140
MAN	81.43601.0150

**Lista corrispondenze**

CONTITECH	1885 NI
FIRESTONE	IR2A 445-280 / W01 095 0429
PHOENIX	IF 20B-1
TAURUS	
DUNLOP UK	
DUNLOP F	
GOODYEAR	9003
PIRELLI	
GART	

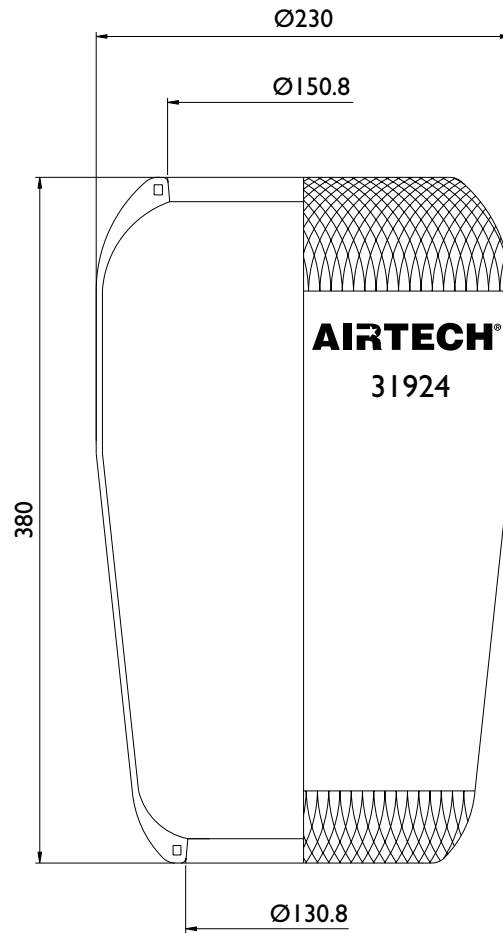
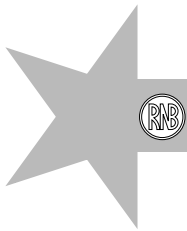
**Applicazioni principali**

RVI	5.000.183.640
RVI	5.010.206.716
RVI	5.010.347.385
RVI	5.010.347.890
RVI	5.010.347.891
VOLVO	1075366

**Lista corrispondenze**

CONTITECH	1924 NI
FIRESTONE	
PHOENIX	
TAURUS	
DUNLOP UK	
DUNLOP F	
GOODYEAR	
PIRELLI	
GART	

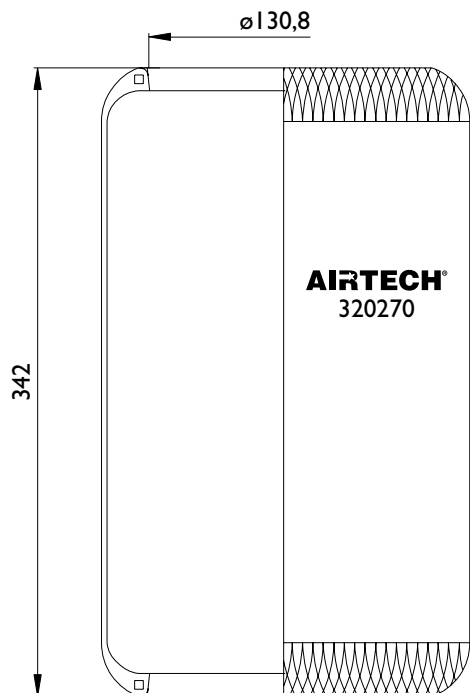

### Applicazioni principali

IVECO BUS 49I	42531994
MENARINI 22I	D020990

### Lista corrispondenze

CONTITECH	
PHOENIX	
DUNLOP UK	
GOODYEAR	
GART	D290E 290.0.340

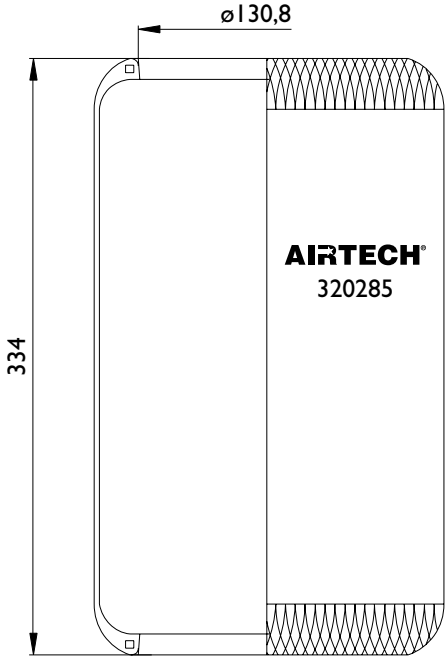

**Applicazioni principali**

IVECO BUS 480 - 580 - 680	4843220

**Lista corrispondenze**

CONTITECH	
FIRESTONE	
PHOENIX	
TAURUS	
DUNLOP UK	
DUNLOP F	
GOODYEAR	
PIRELLI	I S 285-20 / 96534
GART	276/E 276.0.330



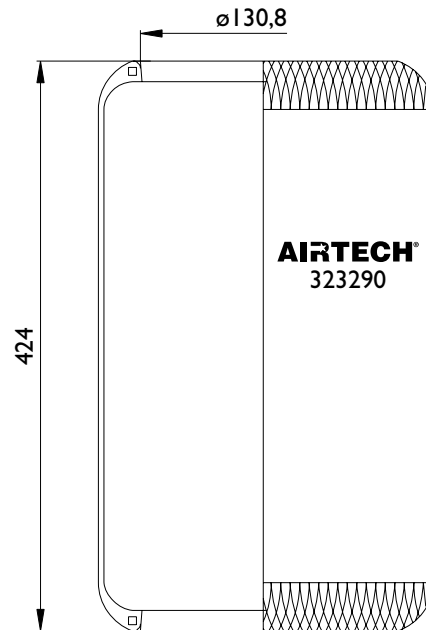

**Applicazioni principali**

IVECO BUS 491	500324098
IVECO CITYCLASS	500324098

**Lista corrispondenze**

CONTITECH	
FIRESTONE	
PHOENIX	
TAURUS	
DUNLOP UK	
DUNLOP F	
GOODYEAR	
PIRELLI	I S 290-23V / 204427
GART	



A520050

AIRTECH® 3415-25

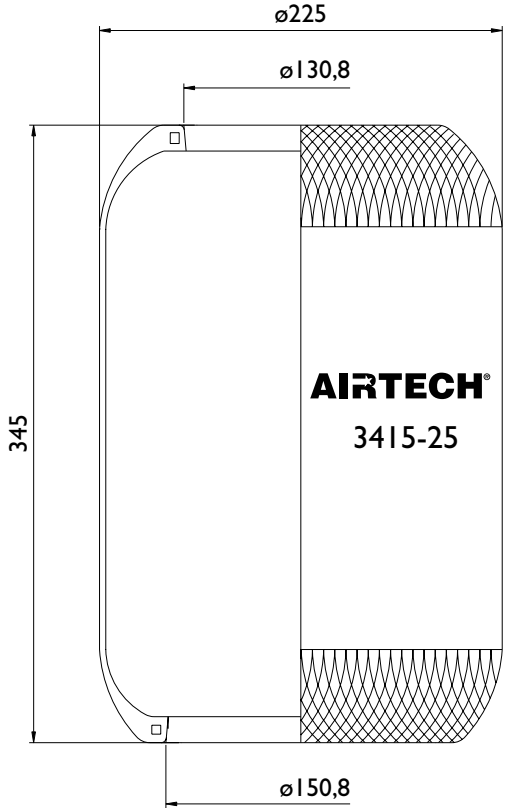

**Applicazioni principali**

VOLVO	3027271

**Lista corrispondenze**

CONTITECH	RZ 415-25
FIRESTONE	1R5P 345-290 / W01 095 0381
PHOENIX	2G 20
TAURUS	B 271
DUNLOP UK	
DUNLOP F	
GOODYEAR	9004
PIRELLI	I S 280-25 / 203000
GART	

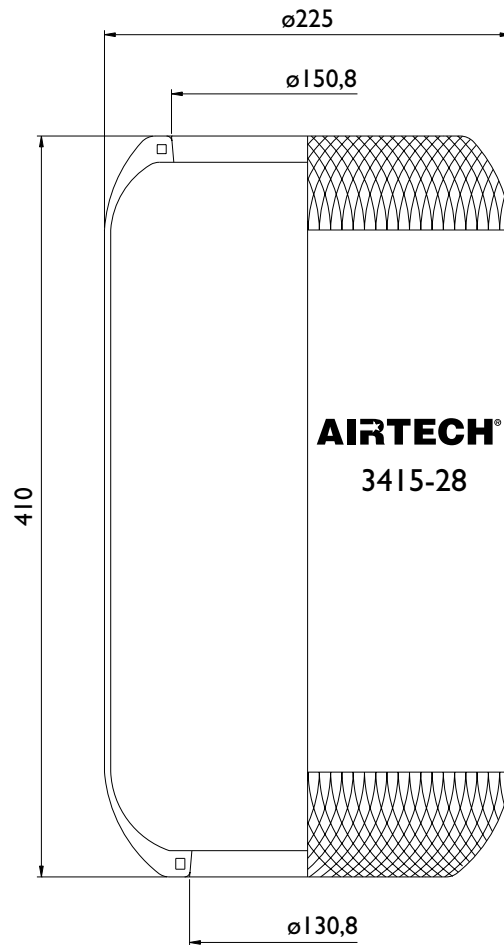

**Applicazioni principali**

VOLVO	3027272

**Lista corrispondenze**

CONTITECH	RZ 415-28
FIRESTONE	1R5P 410-290 / W01 095 0382
PHOENIX	2G 20A
TAURUS	B 272
DUNLOP UK	
DUNLOP F	
GOODYEAR	9005
PIRELLI	I S 280-28 / 203001
GART	

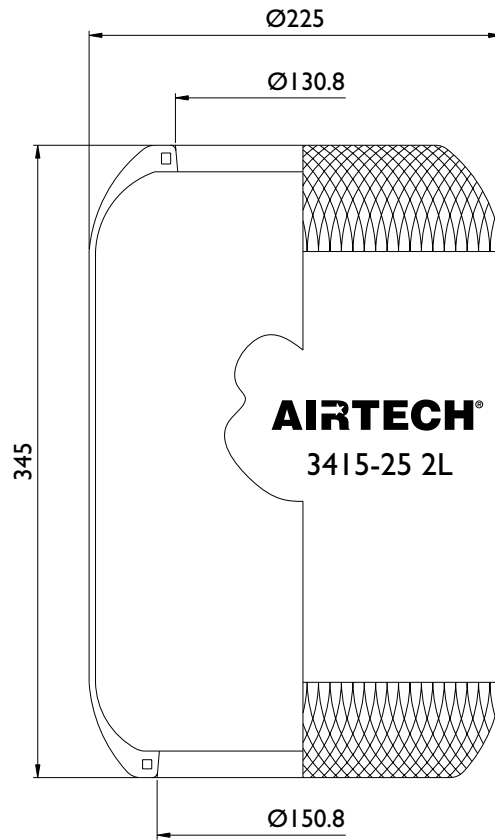
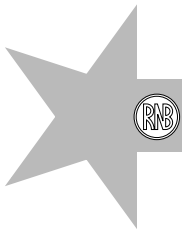

**Applicazioni principali**

**Lista corrispondenze**

CONTITECH	
FIRESTONE	
PHOENIX	
TAURUS	
DUNLOP UK	
DUNLOP F	
GOODYEAR	
PIRELLI	
GART	

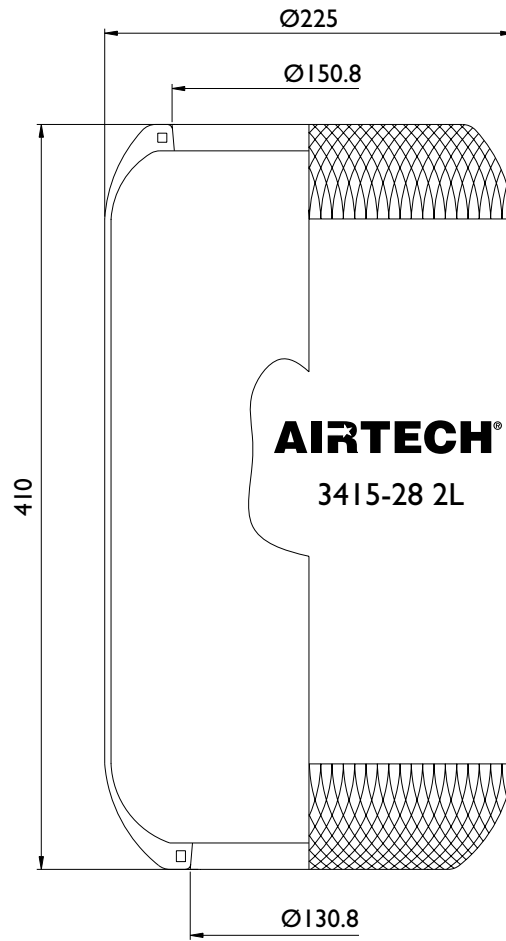

**Applicazioni principali**

**Lista corrispondenze**

CONTITECH	
FIRESTONE	
PHOENIX	
TAURUS	
DUNLOP UK	
DUNLOP F	
GOODYEAR	
PIRELLI	
GART	

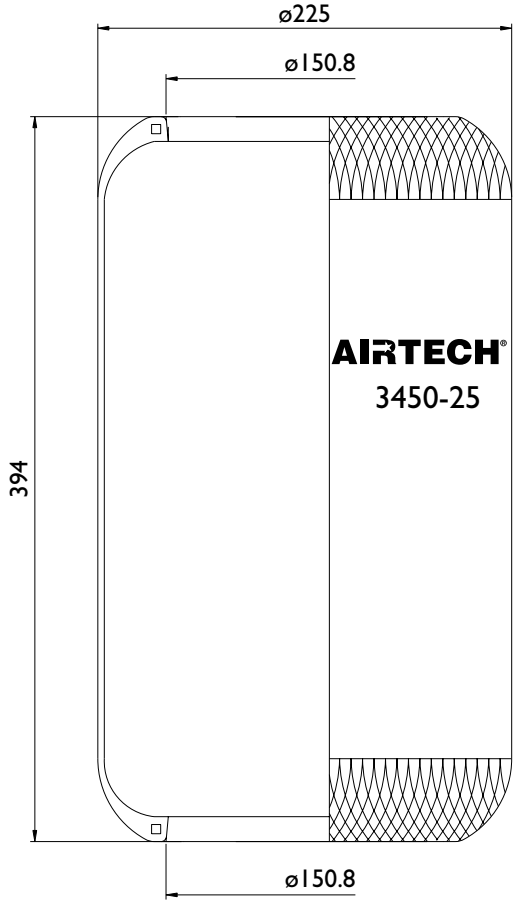

Applicazioni principali

EVO - BUS	356.327.0001

Lista corrispondenze

CONTITECH	RZ 450-25
FIRESTONE	
PHOENIX	IE 23
TAURUS	BL 128
DUNLOP UK	
DUNLOP F	
GOODYEAR	
PIRELLI	I S 300-27 / 203386
GART	

MOLLE AD ARIA COMPLETE







# MOLLE AD ARIA SEMI-COMLETE

 A520067

**AIRTECH® 3725**

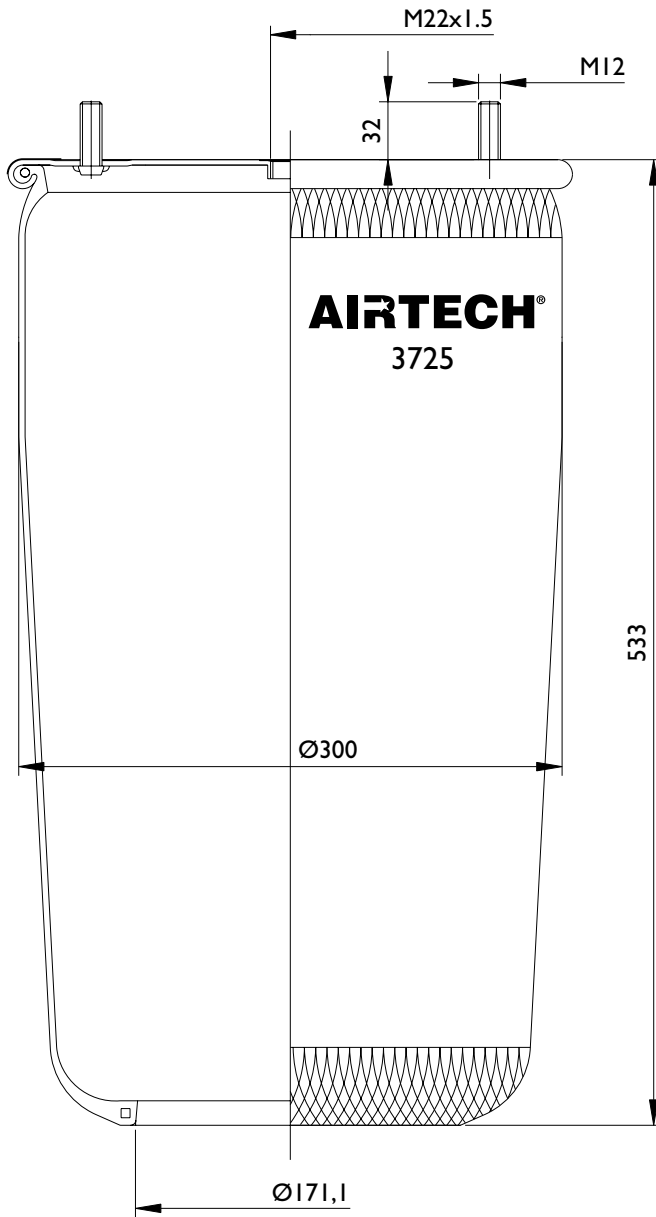

311018 Vista dall'alto

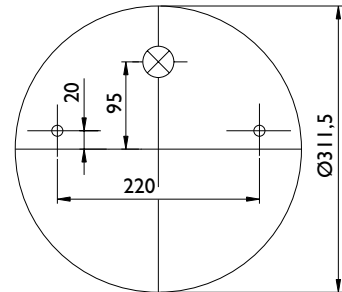

## Applicazioni principali

GIGANT	246149

## Lista corrispondenze

CONTITECH	725 N P01
FIRESTONE	1T66E - 10.8 / W01M58 8969
PHOENIX	1 DF 32
TAURUS	UR 836-11
DUNLOP UK	
DUNLOP F	D14 U38
GOODYEAR	1 R 14-704
PIRELLI	1 TCS 360-45 / 202964
GART	C292S 292.0.533

 Entrata aria

 Perno combinato

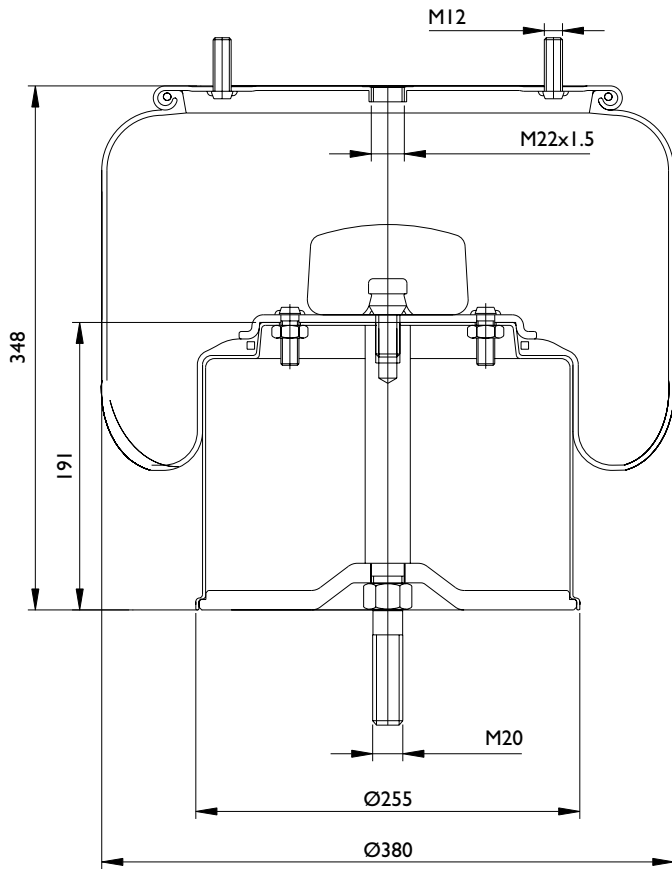
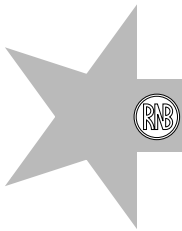

311018 Vista dall'alto

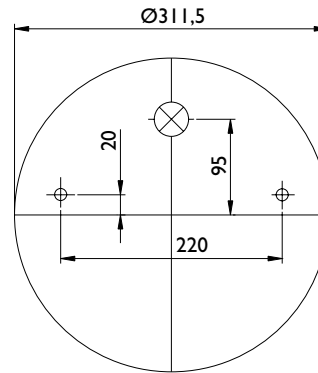

Vista dal basso

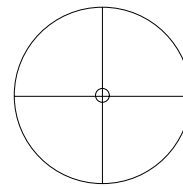

### Applicazioni principali

GIGANT	246149

### Lista corrispondenze

CONTITECH	725 N P02
FIRESTONE	1 T 66 E - 10.8 / W01 M58 8969
PHOENIX	1 DF 32
TAURUS	UR 836-11
DUNLOP UK	
DUNLOP F	
GOODYEAR	1 R 14 - 747
PIRELLI	
GART	

⊗ Entrata aria

⊗ Perno combinato

# MOLLE AD ARIA COMPLETE

 **A520125C**

**AIRTECH® 3725-01K** 

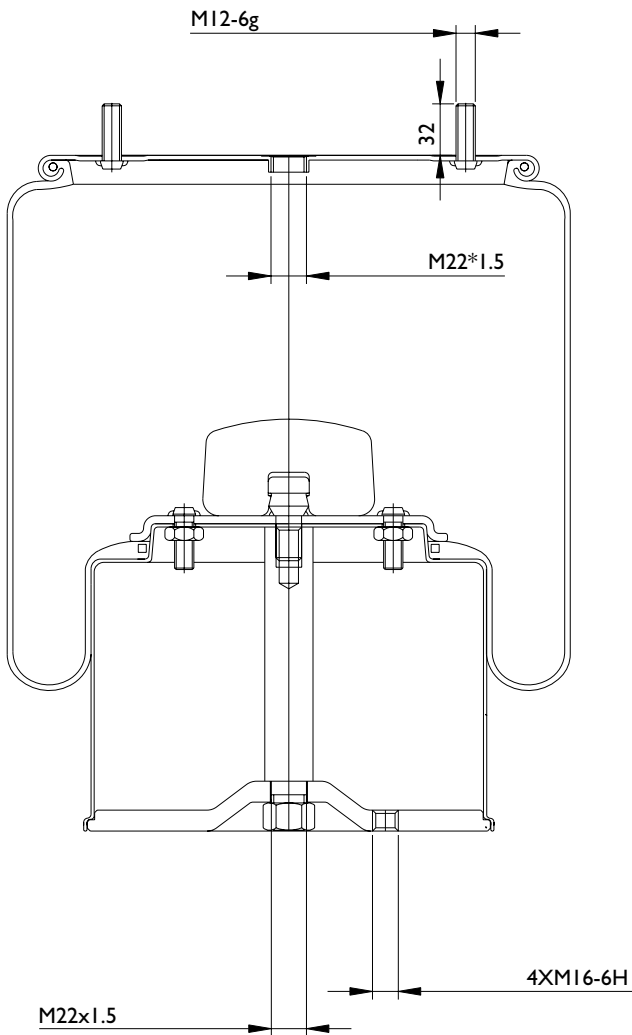

311018 Vista dall'alto

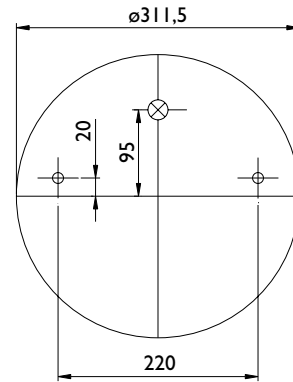

Vista dal basso

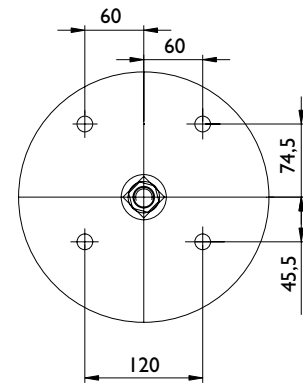



## Applicazioni principali

GIGANT	I66252

## Lista corrispondenze

CONTITECH	725 N P03
FIRESTONE	
PHOENIX	
TAURUS	
DUNLOP UK	
DUNLOP F	
GOODYEAR	
PIRELLI	
GART	

 Entrata aria

 Perno combinato

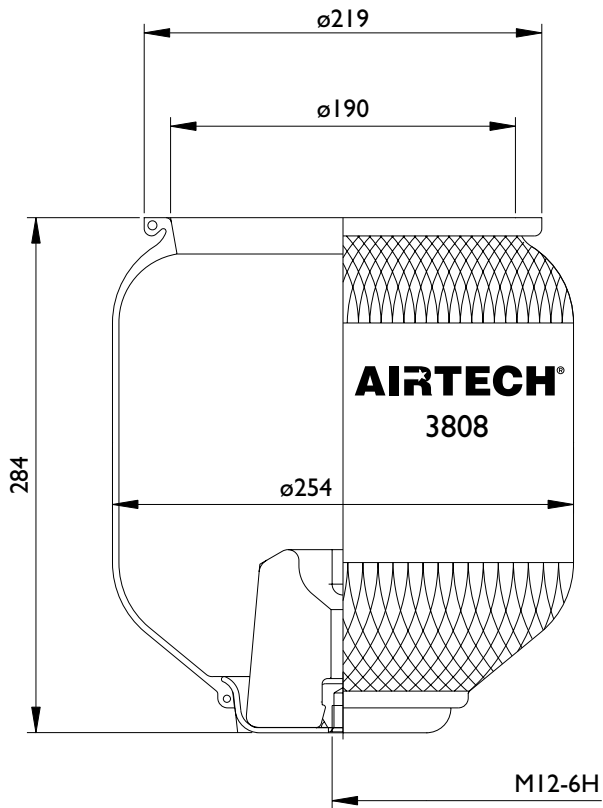

315001 Vista dal basso

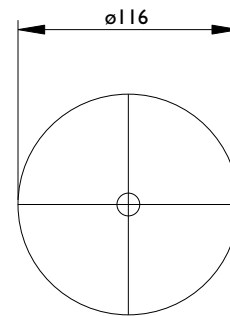

### Applicazioni principali

MAN	81.43601.0044

### Lista corrispondenze

CONTITECH	808 NT
FIRESTONE	
PHOENIX	I D 23A-I
TAURUS	UR 500-13
DUNLOP UK	
DUNLOP F	
GOODYEAR	
PIRELLI	
GART	

Entrata aria

Perno combinato

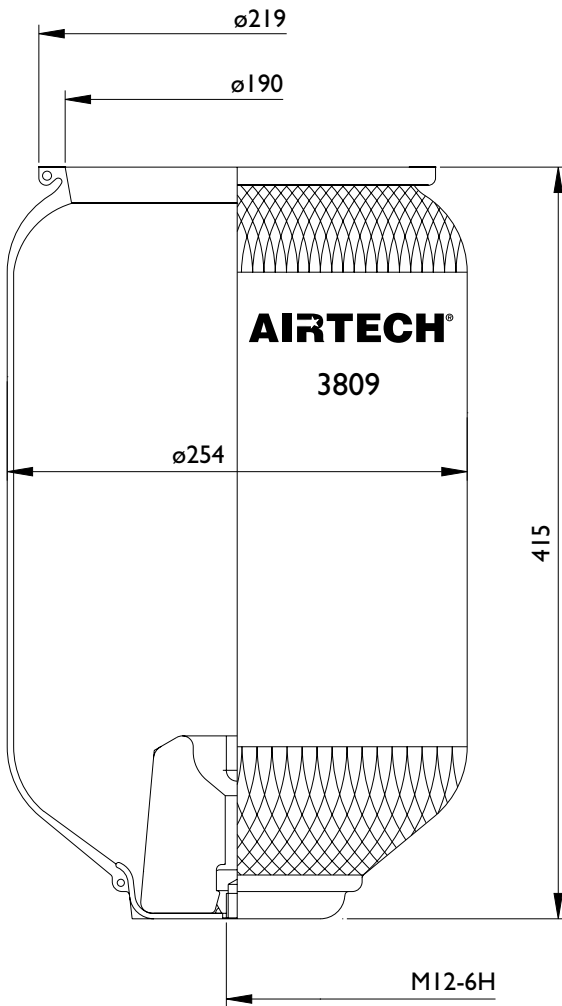

315001 Vista dal basso

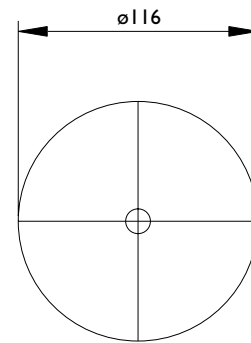

### Applicazioni principali

IVECO PEGASO BUS	174932
MAN	81.43601.0025
MAN	81.43601.0050
MAN	81.43601.6002
MAN	81.43601.6023
MAN	81.43601.6025
MAN	81.43601.6029
MAN	81.43601.6030

### Lista corrispondenze

CONTITECH	809 NTB
FIRESTONE	I T 15 L-6 / W01 M58 0687
PHOENIX	I D 23 C I
TAURUS	UR 504-13
DUNLOP UK	
DUNLOP F	
GOODYEAR	I R 12-709
PIRELLI	I T 320 SP / 89753
GART	

⊗ Entrata aria

⊗ Perno combinato

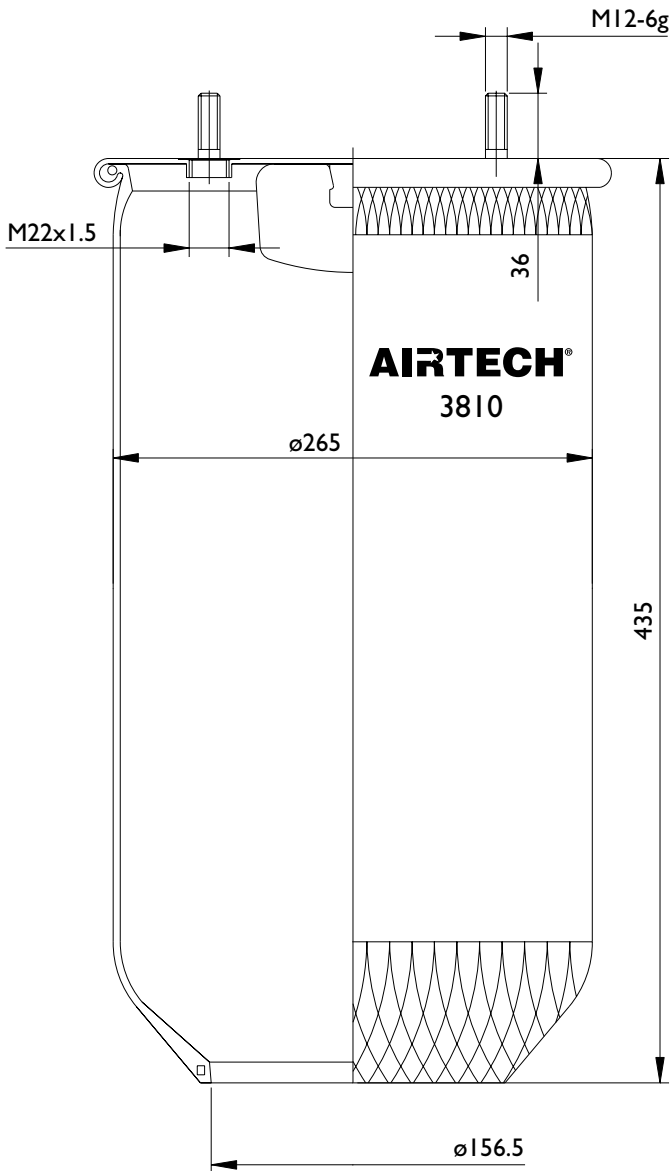
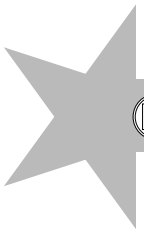

311003 Vista dall'alto

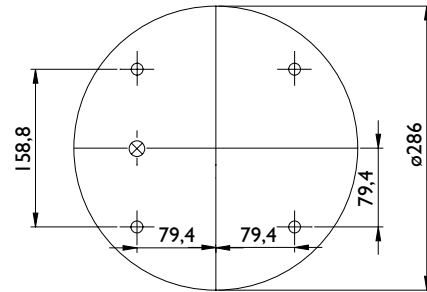

### Applicazioni principali

### Lista corrispondenze

CONTITECH	810 N
FIRESTONE	1T15L7 / W01 M580491/0749
PHOENIX	I D 28A
TAURUS	
DUNLOP UK	PNP 307320000
DUNLOP F	
GOODYEAR	
PIRELLI	
GART	

⊗ Entrata aria

⊗ Perno combinato

# MOLLE AD ARIA COMPLETE

 **A520010C**

**AIRTECH® 3810 K** 

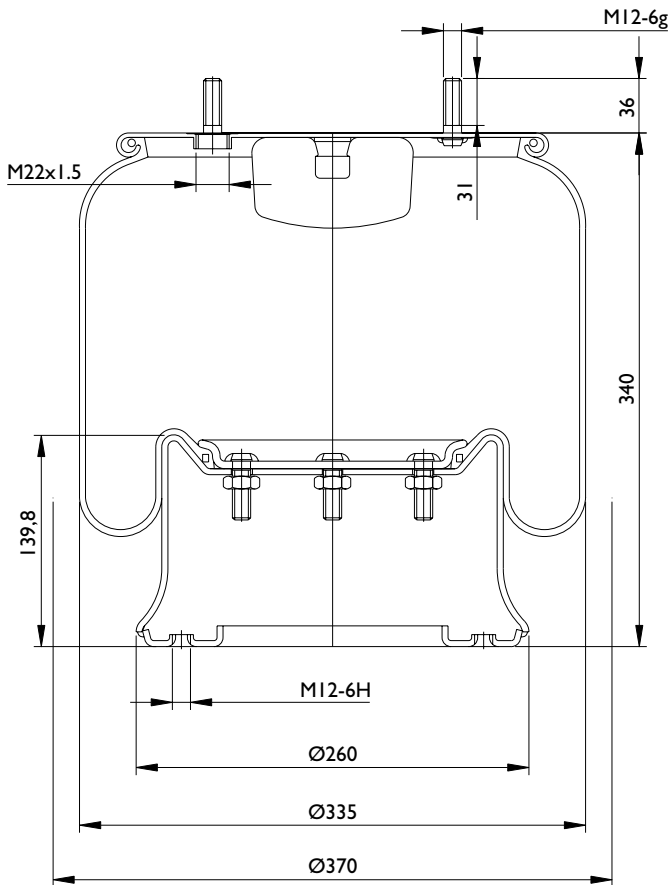

311003 Vista dall'alto

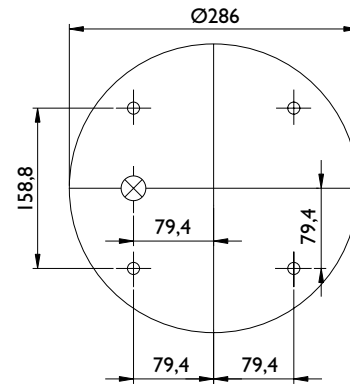

312016 Vista dal basso

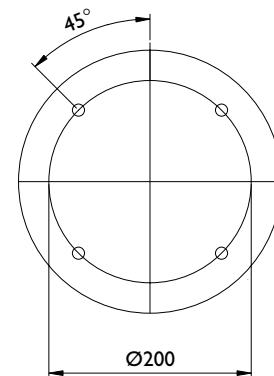



## Applicazioni principali

GRANNING	I5635
HENDRICKSON	506243
NEWAY	211 586
ROR / MERITOR	21208082
ROR / MERITOR	21215632
RVI	5000452939
SAF	2229000200
SAMRO	250.000.08
TRAILOR	6504646G
TROUILLET	MB10315
VOLVO	1080707
WEWELER	21208082
WEWELER	US00622
WEWELER	US07337
WEWELER	US874131F
YORK	785168

## Lista corrispondenze

CONTITECH	810 MB
FIRESTONE	I T 19 L-7 / W01 M58 6345/8775
PHOENIX	I D28 A-2
TAURUS	K621-26
DUNLOP UK	PNP 311670000
DUNLOP F	D13 B20
GOODYEAR	I R 14-716
PIRELLI	I T 19 E-I / 87413/I
GART	D277/B 277.4.420

 Entrata aria

 Perno combinato

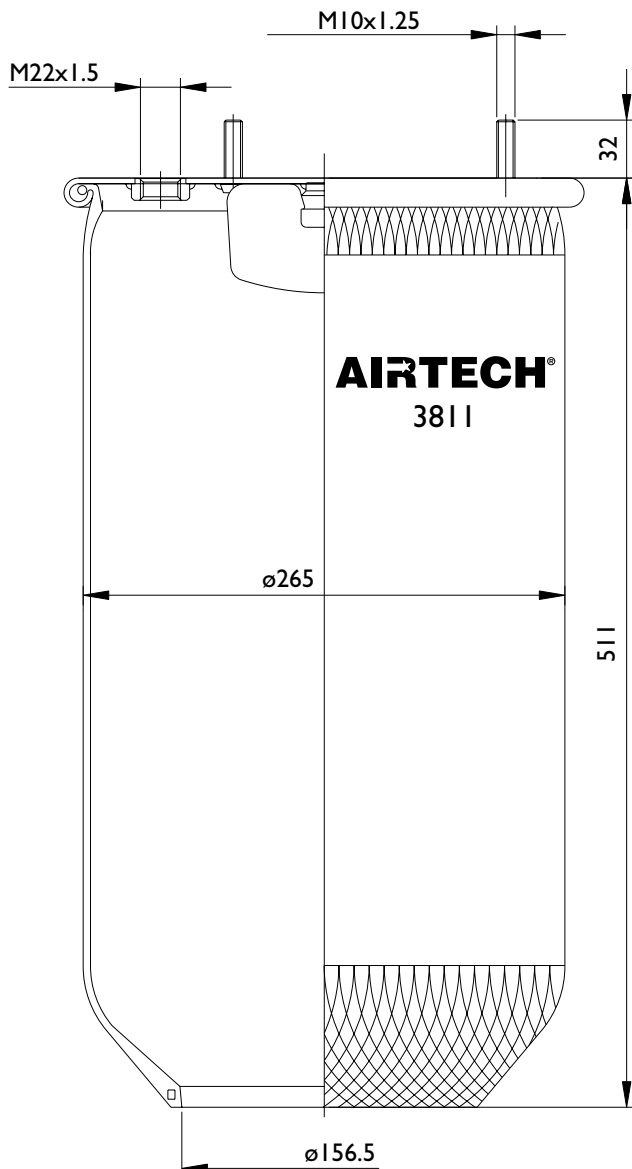

311007 Vista dall'alto

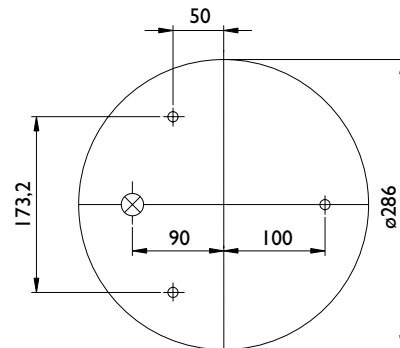

### Applicazioni principali

DAF	0067306
DAF TRUCKS SB3000	0067452
DAF	0676122
EVO-BUS	4731029000

### Lista corrispondenze

CONTITECH	811 M 16
FIRESTONE	1 T 19 F-11 / W01 M58 6333
PHOENIX	
TAURUS	
DUNLOP UK	
DUNLOP F	SP2066
GOODYEAR	
PIRELLI	1T19E2
GART	

⊗ Entrata aria

⊗ Perno combinato



# MOLLE AD ARIA COMPLETE



A520081C

AIRTECH® 3811 K

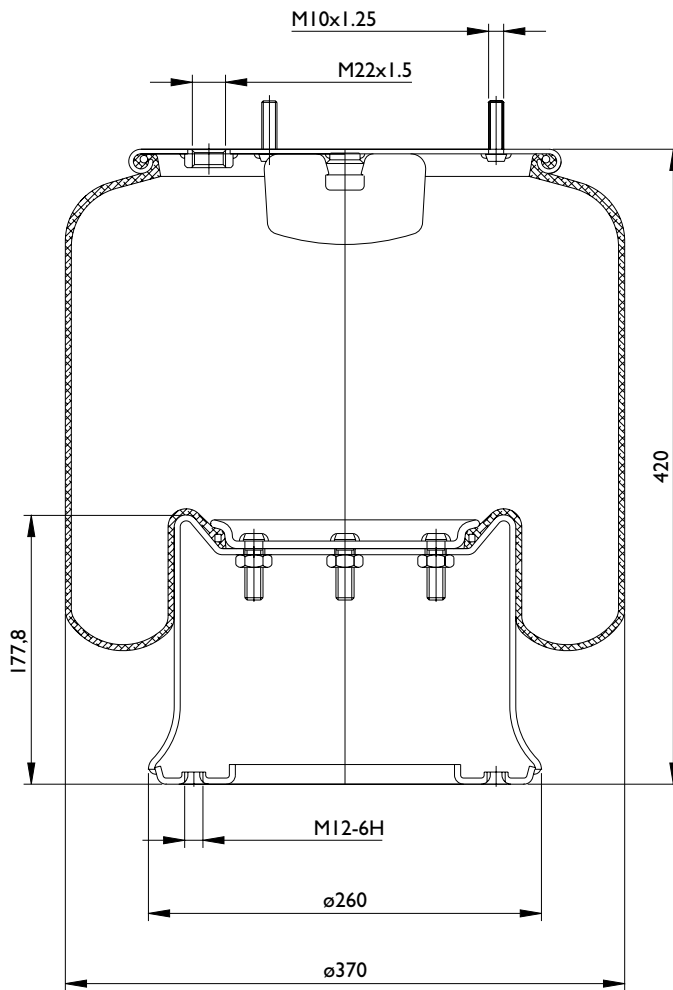

311007 Vista dall'alto

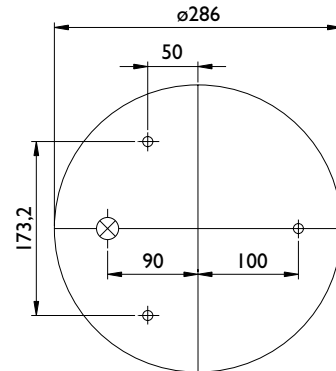

312014 Vista dal basso

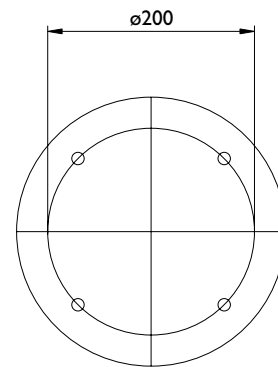

## Applicazioni principali

DAF	0526823
RVI	5000745918

## Lista corrispondenze

CONTITECH	811 MB / 811 M16 KI
FIRESTONE	1 T 19 F-11 / W01 M58 6334
PHOENIX	ID28 - B7
TAURUS	KR 622 - 31
DUNLOP UK	
DUNLOP F	D13 B17
GOODYEAR	1 R14 - 718
PIRELLI	1 T 19 E-2 / 203878
GART	D277 277.4.506



Entrata aria



Perno combinato

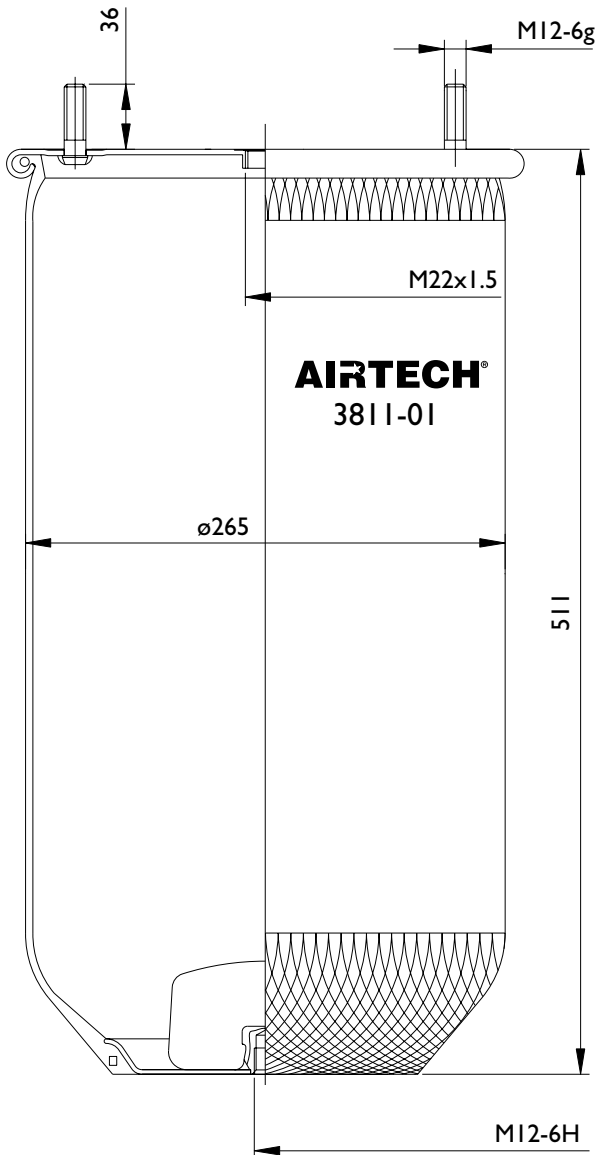
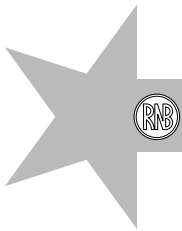

311005 Vista dall'alto

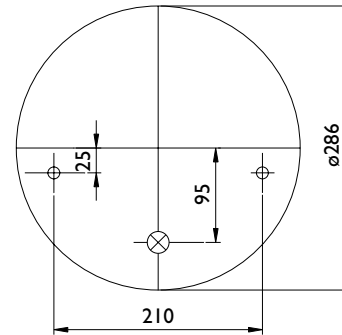

315002 Vista dal basso

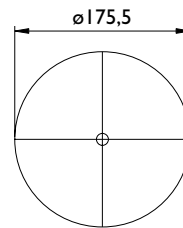

### Applicazioni principali

### Lista corrispondenze

CONTITECH	CONTITECH	811 MB
FIRESTONE		1 T 19 F-11
PHOENIX		
TAURUS		K 622-26 SM
DUNLOP UK		PNP 311670000
DUNLOP F		
GOODYEAR		1R14-719
PIRELLI		1 T 19E-2
GART		

⊗ Entrata aria

⊗ Perno combinato

# MOLLE AD ARIA COMPLETE



## AIRTECH® 3811-01 K

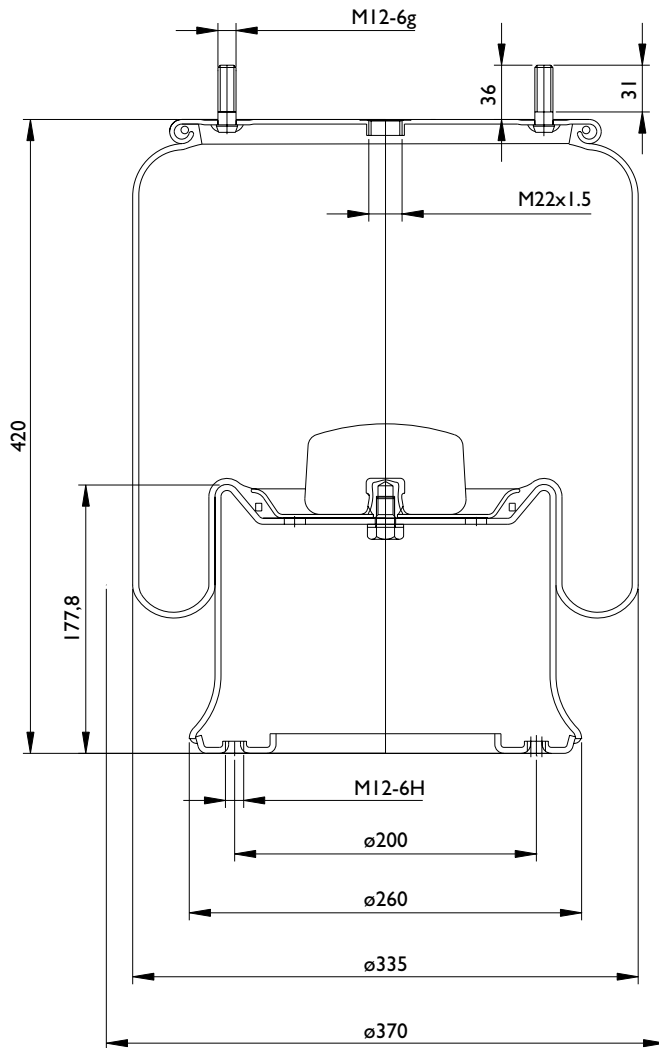

311005 Vista dall'alto

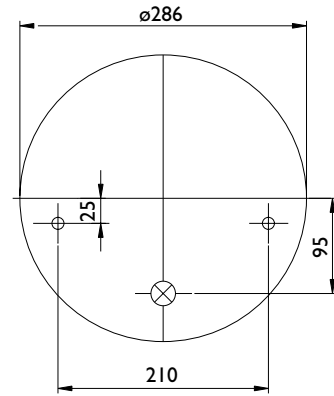

311005 Vista dal basso

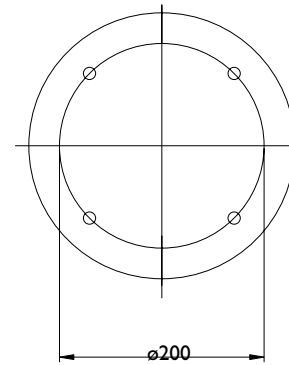

### Applicazioni principali

SAF	3.229.0031.00

### Lista corrispondenze

CONTITECH	811 MB
FIRESTONE	
PHOENIX	
TAURUS	
DUNLOP UK	
DUNLOP F	
GOODYEAR	
PIRELLI	
GART	

⊗ Entrata aria

⊗ Perno combinato

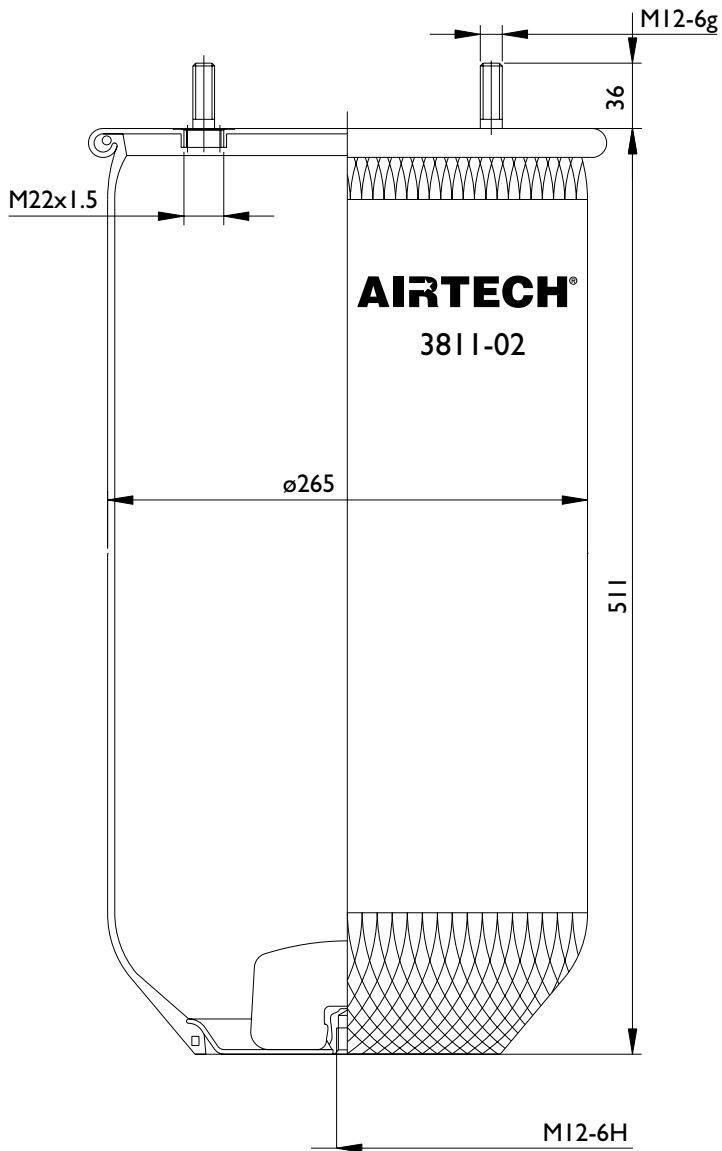

311004 Vista dall'alto

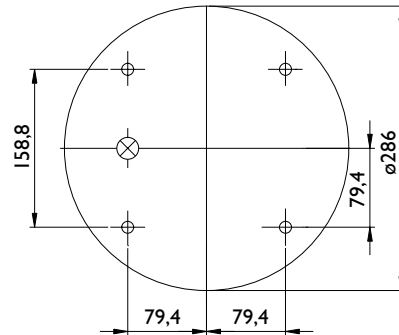

315002 Vista dal basso

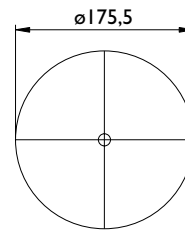

### Applicazioni principali



### Lista corrispondenze

CONTITECH	811
FIRESTONE	1 T 19 L-11
PHOENIX	
TAURUS	KR 622-31
DUNLOP UK	
DUNLOP F	
GOODYEAR	
PIRELLI	
GART	

⊗ Entrata aria

⊗ Perno combinato

# MOLLE AD ARIA COMPLETE

 **A520174C**

**AIRTECH® 3811-02 K**

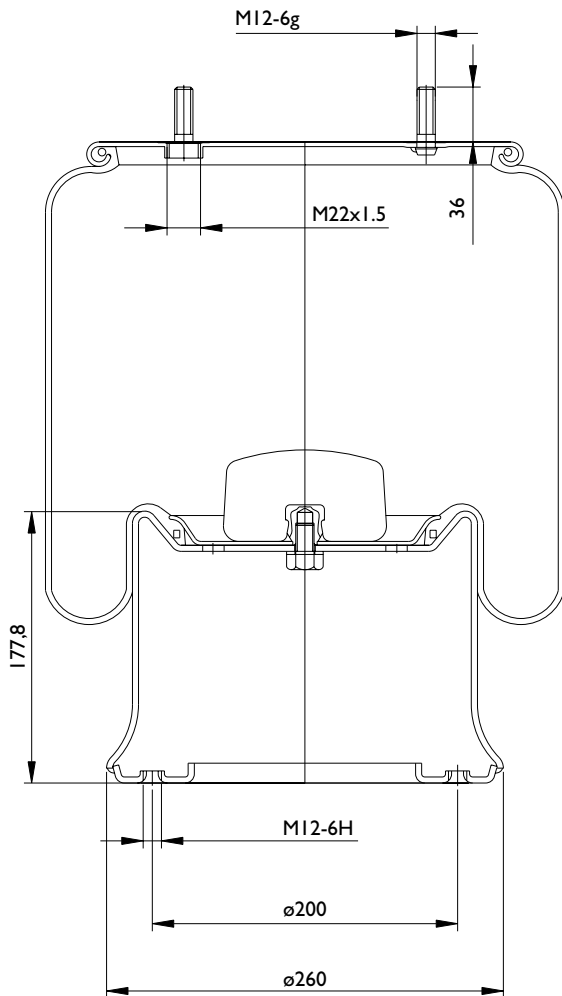

311004 Vista dall'alto

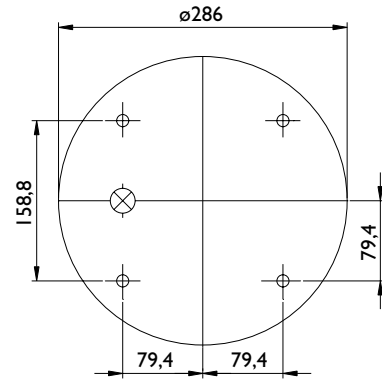

312014 Vista dal basso

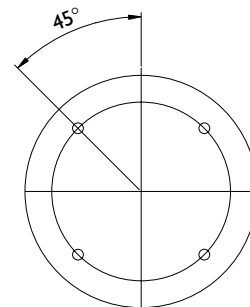



## Applicazioni principali

CAMPANA	050200105

## Lista corrispondenze

CONTITECH	
FIRESTONE	
PHOENIX	
TAURUS	
DUNLOP UK	
DUNLOP F	
GOODYEAR	
PIRELLI	
GART	D287 287.4.522

 Entrata aria

 Perno combinato

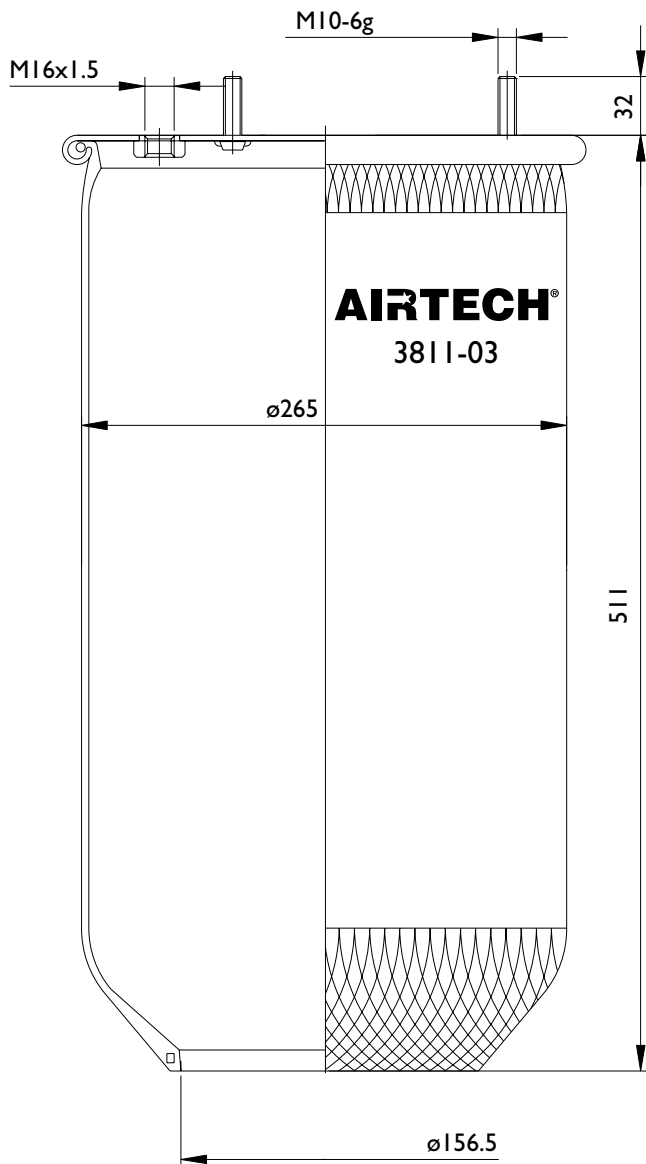
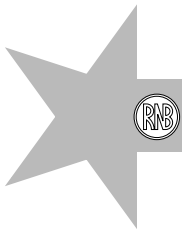

311010 Vista dall'alto

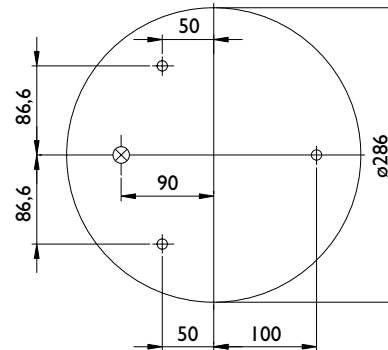

### Applicazioni principali

### Lista corrispondenze

CONTITECH	811 MB 3
FIRESTONE	1 T 19 F-11 / W01 M58 6359
PHOENIX	
TAURUS	
DUNLOP UK	
DUNLOP F	
GOODYEAR	
PIRELLI	
GART	

⊗ Entrata aria

⊗ Perno combinato

# MOLLE AD ARIA SEMI-COMLETE



**AIRTECH® 3811-04**

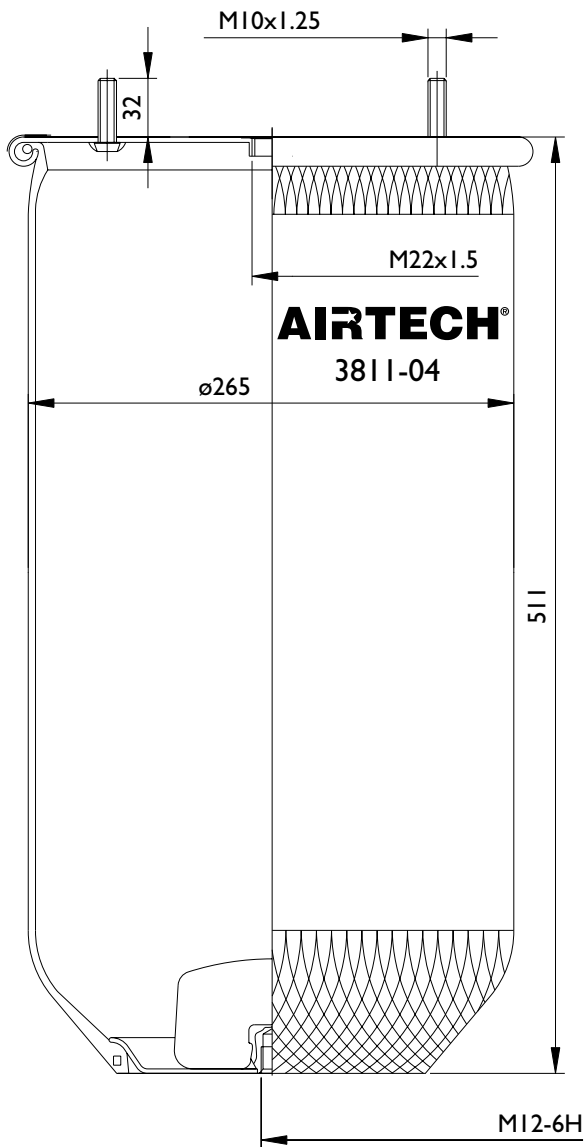

311017 Vista dall'alto

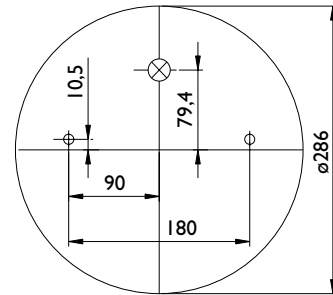

315002 Vista dal basso

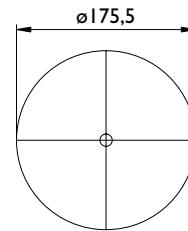

## Applicazioni principali

## Lista corrispondenze

CONTITECH	
FIRESTONE	
PHOENIX	
TAURUS	
DUNLOP UK	
DUNLOP F	
GOODYEAR	
PIRELLI	
GART	

⊗ Entrata aria

⊗ Perno combinato

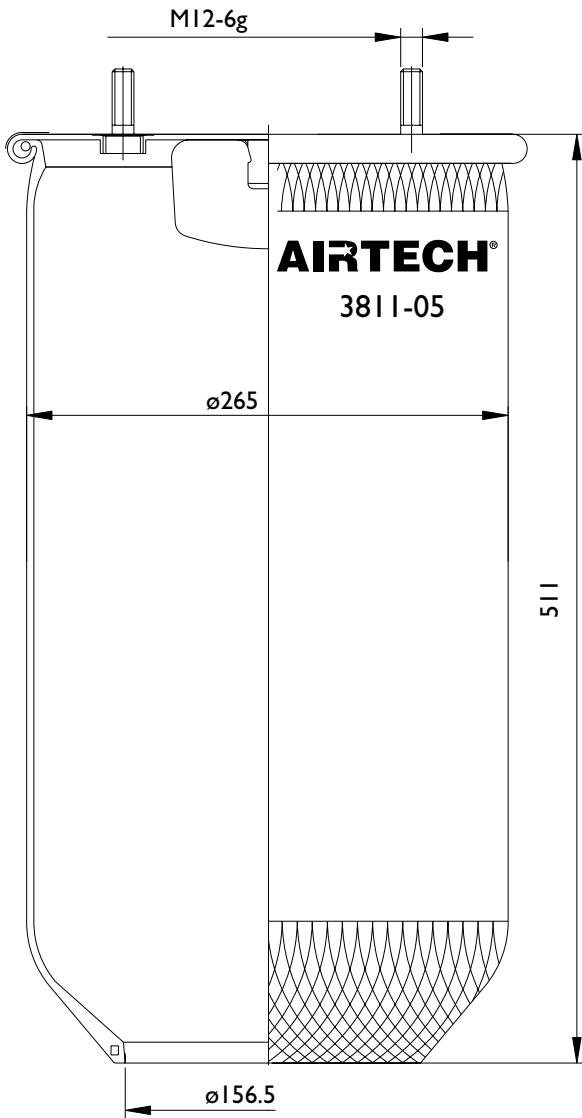

311003 Vista dall'alto

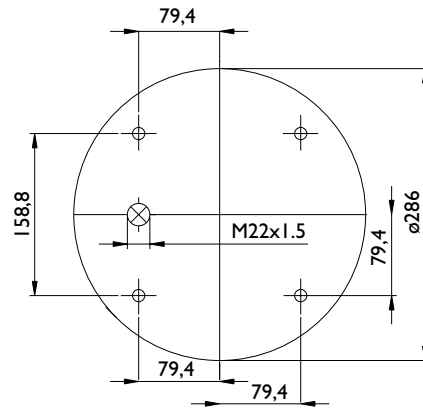

### Applicazioni principali

### Lista corrispondenze

CONTITECH	
FIRESTONE	
PHOENIX	
TAURUS	
DUNLOP UK	
DUNLOP F	
GOODYEAR	
PIRELLI	
GART	

⊗ Entrata aria

⊗ Perno combinato



# MOLLE AD ARIA SEMI-COMLETE



## AIRTECH® 3811-06

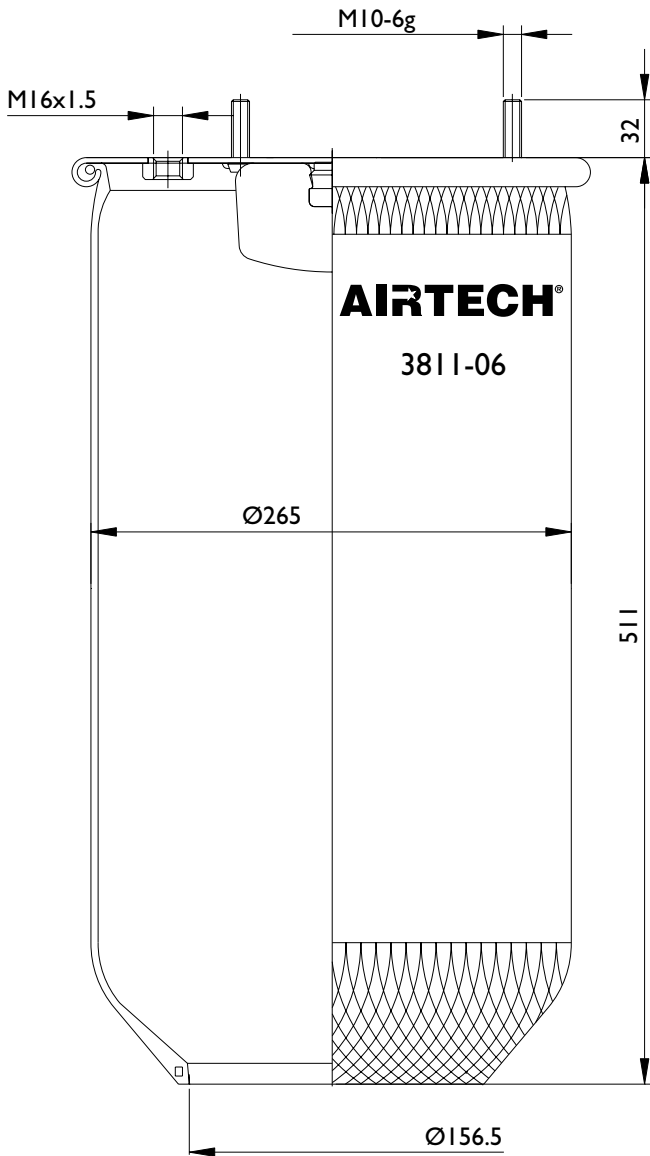

311002 Vista dall'alto

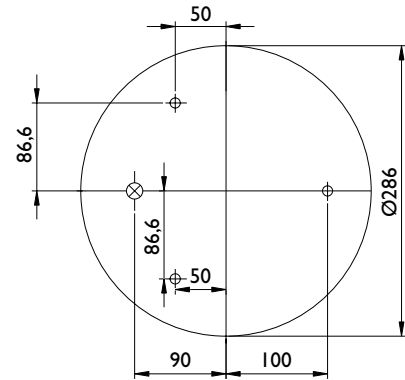

### Applicazioni principali

TOUGHLINE	

### Lista corrispondenze

CONTITECH	811 MB 3
FIRESTONE	1 T 19 F-11 /W01 M58 6359
PHOENIX	
TAURUS	
DUNLOP UK	
DUNLOP F	
GOODYEAR	
PIRELLI	
GART	

⊗ Entrata aria

⊗ Perno combinato

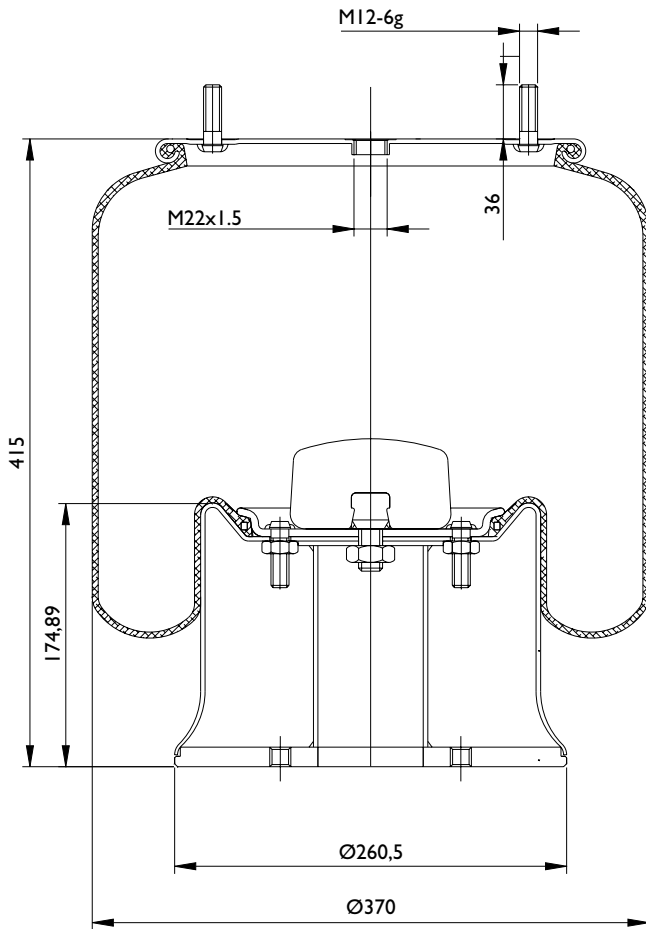
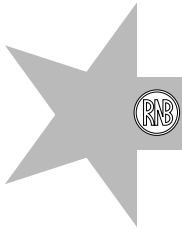

311005 Vista dall'alto

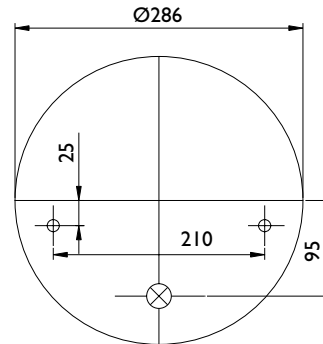

Vista dal basso

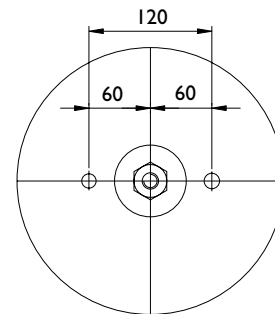

### Applicazioni principali

### Lista corrispondenze

CONTITECH	811 MB
FIRESTONE	
PHOENIX	
TAURUS	
DUNLOP UK	
DUNLOP F	
GOODYEAR	
PIRELLI	
GART	

⊗ Entrata aria

⊗ Perno combinato

# MOLLE AD ARIA COMPLETE



**AIRTECH® 3811-07 K**

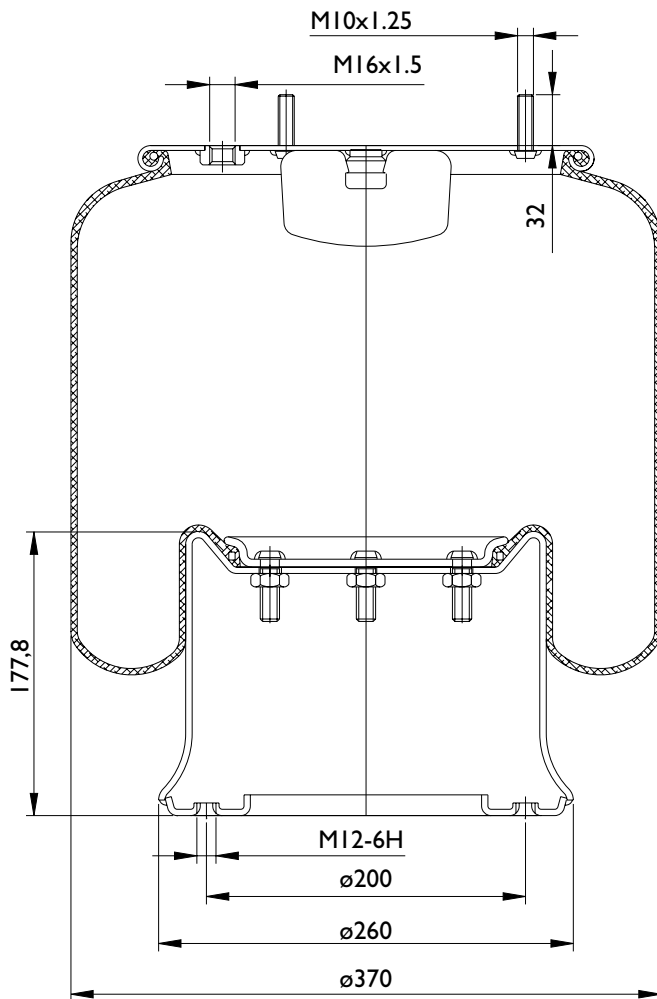

311002 Vista dall'alto

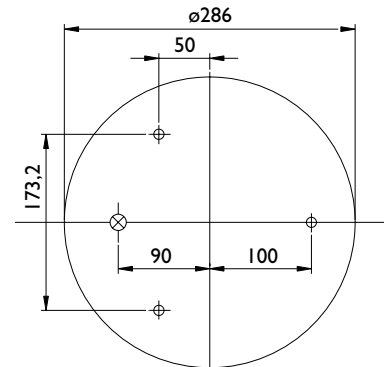

312014 Vista dal basso

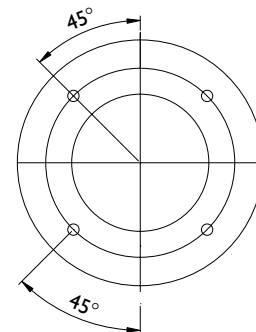

## Applicazioni principali

## Lista corrispondenze

CONTITECH	811 M16 K I
FIRESTONE	1 T 19 F-11 /W01 M58 6334
PHOENIX	
TAURUS	
DUNLOP UK	
DUNLOP F	D 13 B 24
GOODYEAR	1 R 14-719
PIRELLI	
GART	

⊗ Entrata aria

⊗ Perno combinato



A520070

**AIRTECH® 3813**

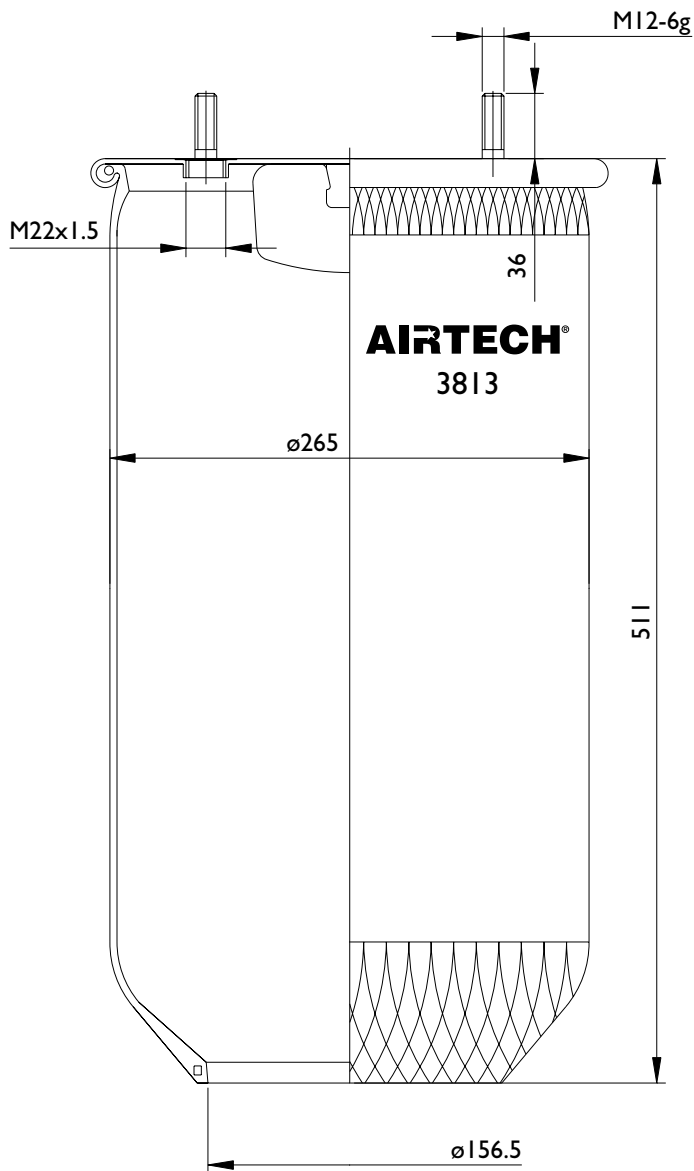

311003 Vista dall'alto

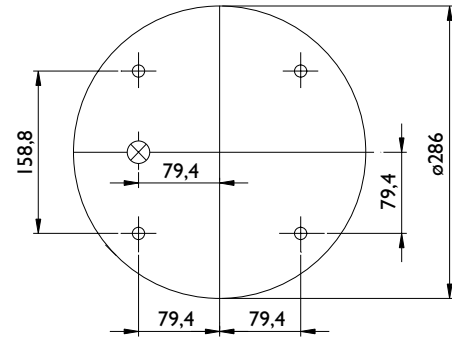

## Applicazioni principali

## Lista corrispondenze

CONTITECH	813 MB 0
FIRESTONE	1 T 19 L-11
PHOENIX	
TAURUS	
DUNLOP UK	
DUNLOP F	
GOODYEAR	
PIRELLI	
GART	

⊗ Entrata aria

⊗ Perno combinato

# MOLLE AD ARIA COMPLETE



A520070C

AIRTECH® 3813 K

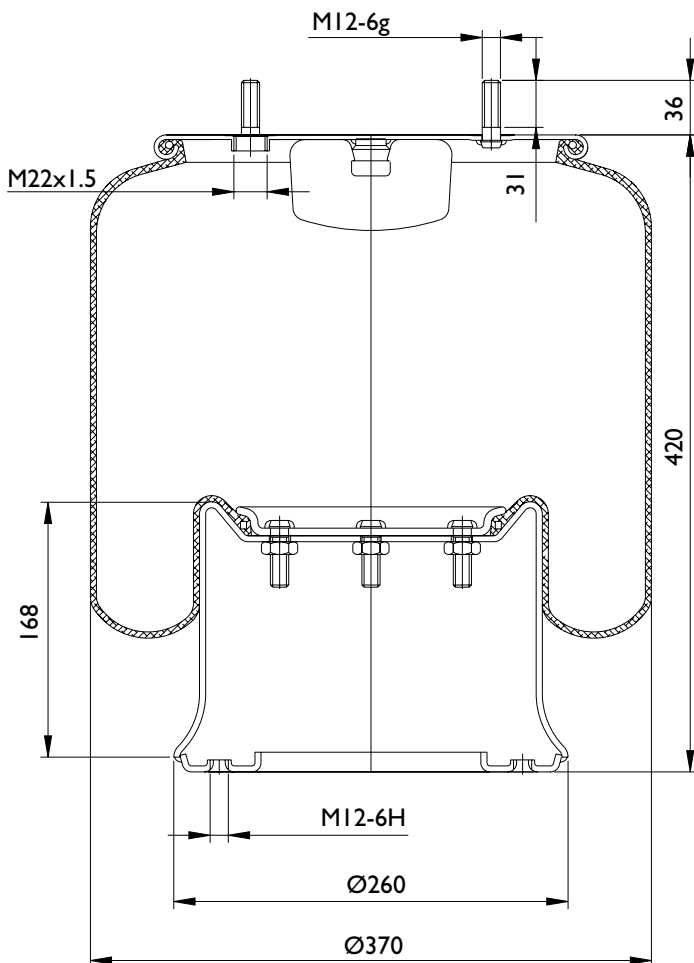

311003 Vista dall'alto

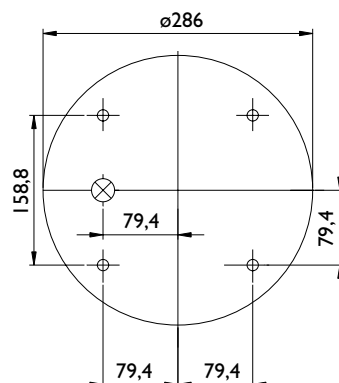

312014 Vista dal basso

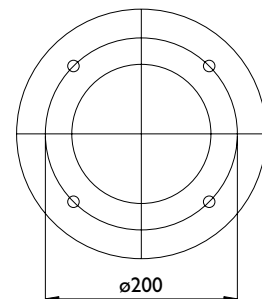

## Applicazioni principali

BARTOLETTI	91619005
BATTAGLINO	2211400
CARDI	58051000
DAF	388491
ERF	143908-3
FRUEHAUF	003615E
GRANNING	15634
HENDRICKSON	505859
KASSBOHRER	4.731.030.000
KASSBOHRER	4.731.033.000
NEWAY	22282
PEGASO	175005
PIACENZA	250991
ROR / MERITOR	21215633
RVI	5000790692
RVI	5010130925
SAE	8403/102
SAF	2.229.0003.00
SAF	3.229.0003.00
SAMRO	2500009
TEC	505801
TERBERG	21071483
TITAN	91687700000
TRAILOR	0036158E
VIBERTI	128147122
VIBERTI	644225
WEWELER	US07345.F
WEWELER	US87408
YORK	785170

## Lista corrispondenze

CONTITECH	813 MB
FIRESTONE	I T 19 F-11/W01 M58 6364
PHOENIX	I D 28 B-2 E2
TAURUS	KR 622-26
DUNLOP UK	PNP 311 56/78
DUNLOP F	D13 B19
GOODYEAR	(I R 14-061) I R 14-705
PIRELLI	I T 19 E-2 / 87408
GART	D277 277.4.500



Entrata aria



Perno combinato

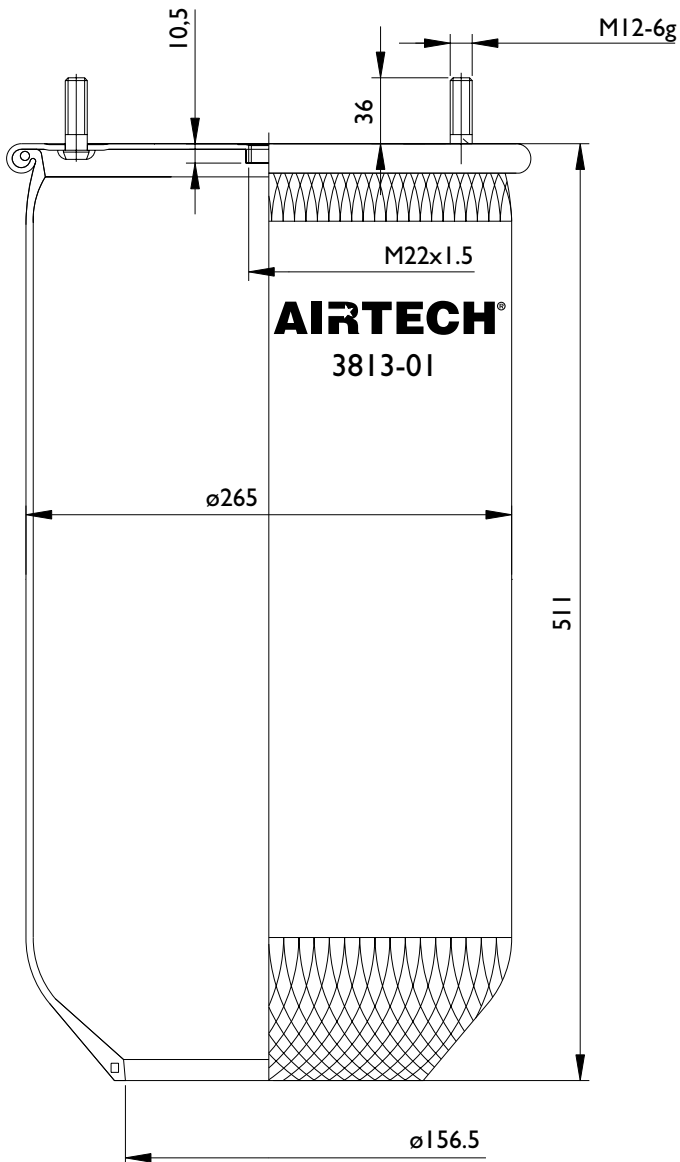
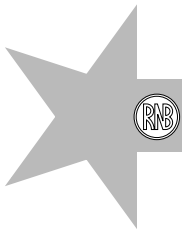

311005 Vista dall'alto

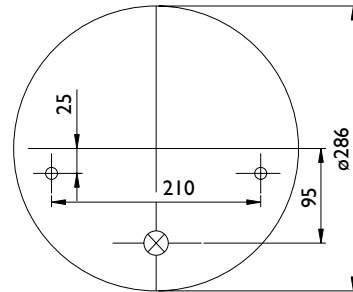

### Applicazioni principali

### Lista corrispondenze

CONTITECH	813 MB
FIRESTONE	
PHOENIX	
TAURUS	
DUNLOP UK	
DUNLOP F	D13 U32
GOODYEAR	
PIRELLI	
GART	

⊗ Entrata aria

⊗ Perno combinato

# MOLLE AD ARIA COMPLETE



**AIRTECH® 3813-01 K**

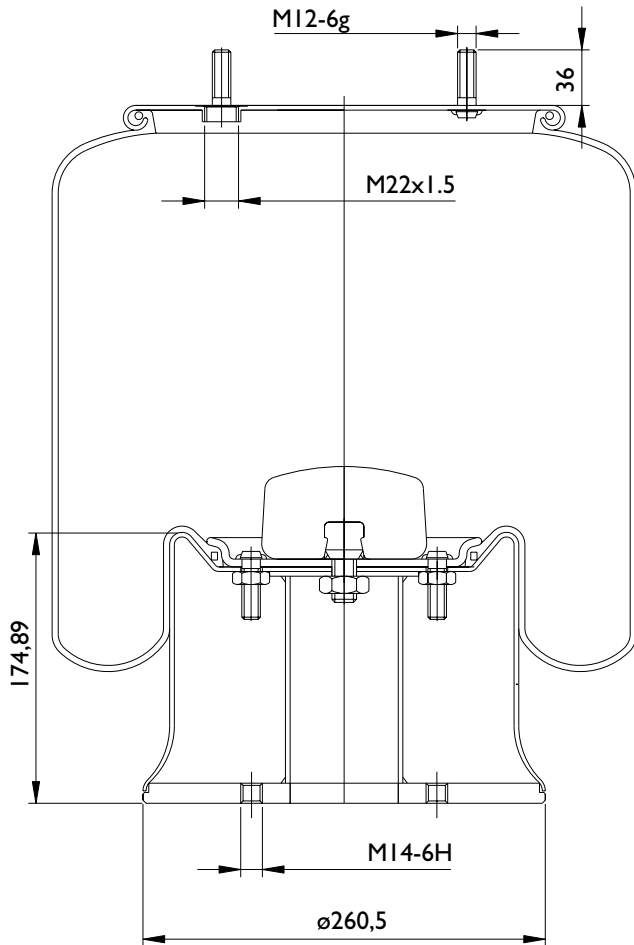

311004 Vista dall'alto

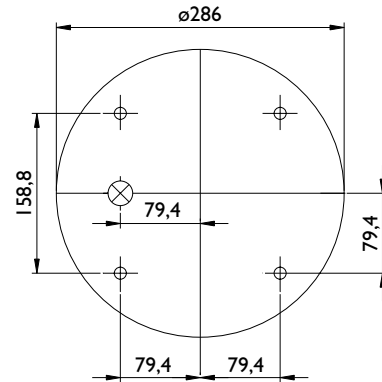

Vista dal basso

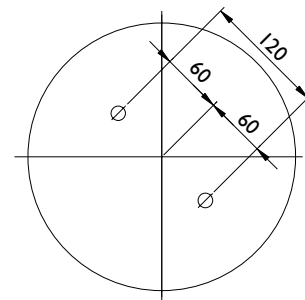

## Applicazioni principali

## Lista corrispondenze

CONTITECH	813 MB
FIRESTONE	
PHOENIX	
TAURUS	
DUNLOP UK	
DUNLOP F	
GOODYEAR	
PIRELLI	
GART	

⊗ Entrata aria

⊗ Perno combinato



**A520169C**

**AIRTECH® 3813-03 K**

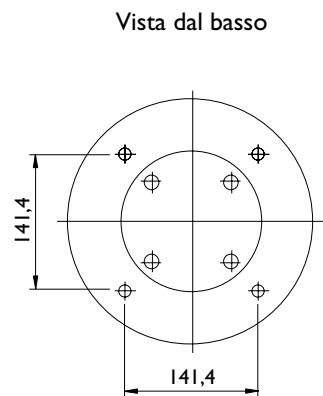
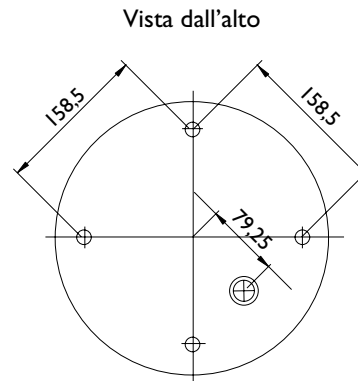
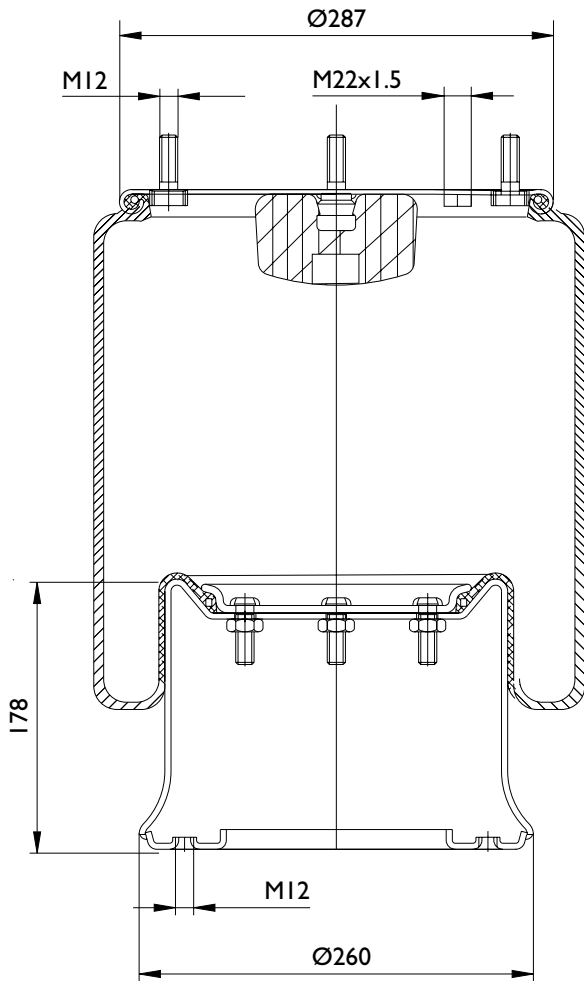

### Applicazioni principali

BATTAGLINO	0.41.03.003.0
B.P.W.	0.41.03.003.0
CAMPANA	05.020.0100

### Lista corrispondenze

CONTITECH	
FIRESTONE	
PHOENIX	
TAURUS	
DUNLOP UK	
DUNLOP F	
GOODYEAR	
PIRELLI	
GART	D227/D 277.4.520

⊗ Entrata aria

⊗ Perno combinato



# MOLLE AD ARIA COMPLETE



## AIRTECH® 3813-05 K

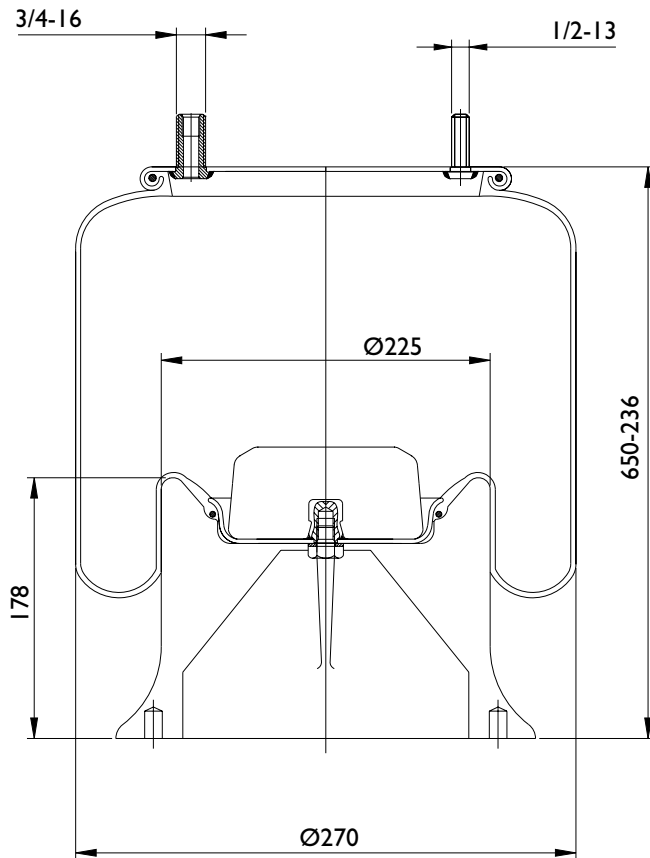

311123 Vista dall'alto

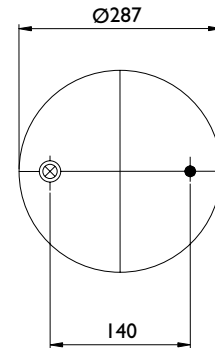

312078 Vista dal basso

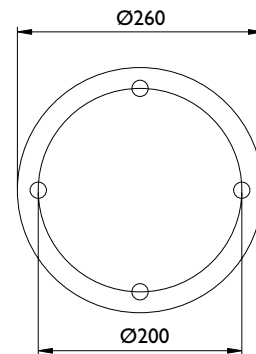

### Applicazioni principali

HENDRICKSON	B3830
NEWAY	90557020
NEWAY	90557069
NEWAY	90557076
NEWAY	90557077
TEC	506003

### Lista corrispondenze

CONTITECH	
FIRESTONE	IT19L-11 / W01 358 9122
PHOENIX	
TAURUS	
DUNLOP UK	
DUNLOP F	
GOODYEAR	IR13-038
PIRELLI	
GART	

⊗ Entrata aria

⊗ Perno combinato

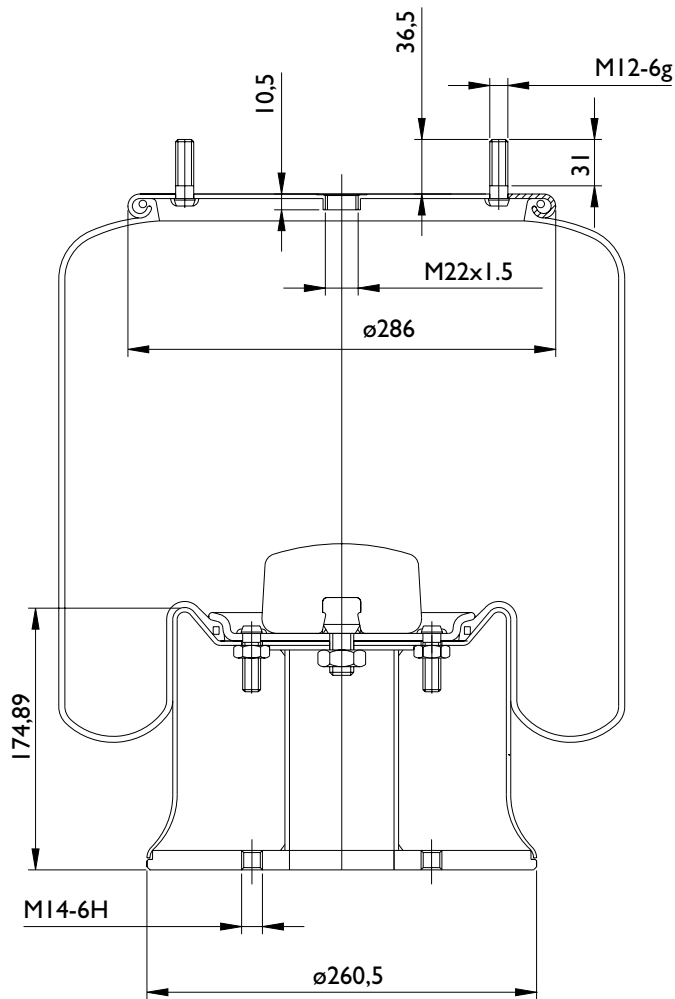
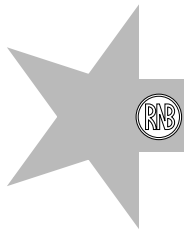

311005 Vista dall'alto

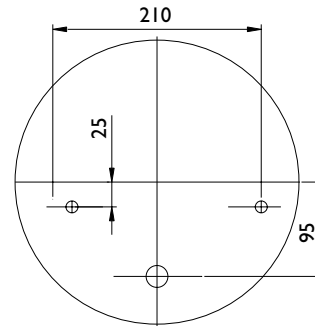

Vista dal basso

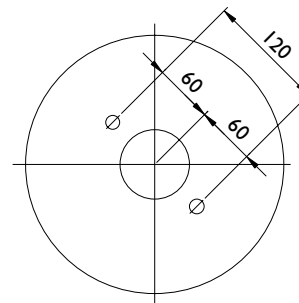

### Applicazioni principali

### Lista corrispondenze

CONTITECH	813 MB
FIRESTONE	
PHOENIX	
TAURUS	
DUNLOP UK	
DUNLOP F	
GOODYEAR	
PIRELLI	
GART	

⊗ Entrata aria

⊗ Perno combinato

# MOLLE AD ARIA SEMI-COMPLETE



A52006 I

**AIRTECH® 3836**

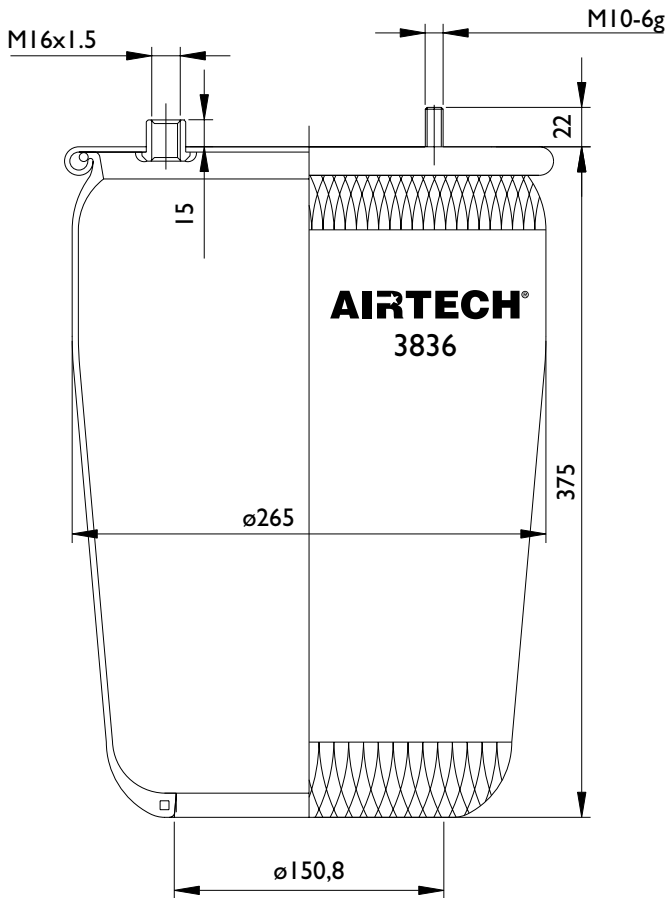

311008 Vista dall'alto

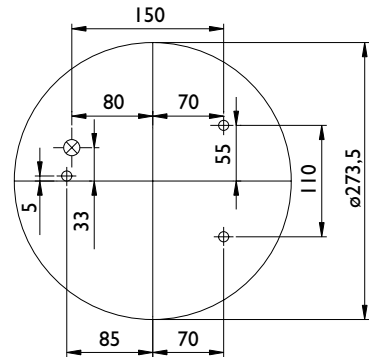

## Applicazioni principali

DAF (con tampone)	0067504
DAF (con tampone)	0513985

## Lista corrispondenze

CONTITECH	836 M
FIRESTONE	
PHOENIX	I DF 25-1
TAURUS	KR 721
DUNLOP UK	
DUNLOP F	D13 U32
GOODYEAR	I R 12-700
PIRELLI	
GART	



Entrata aria



Perno combinato



**A520061C**

**AIRTECH® 3836 K**

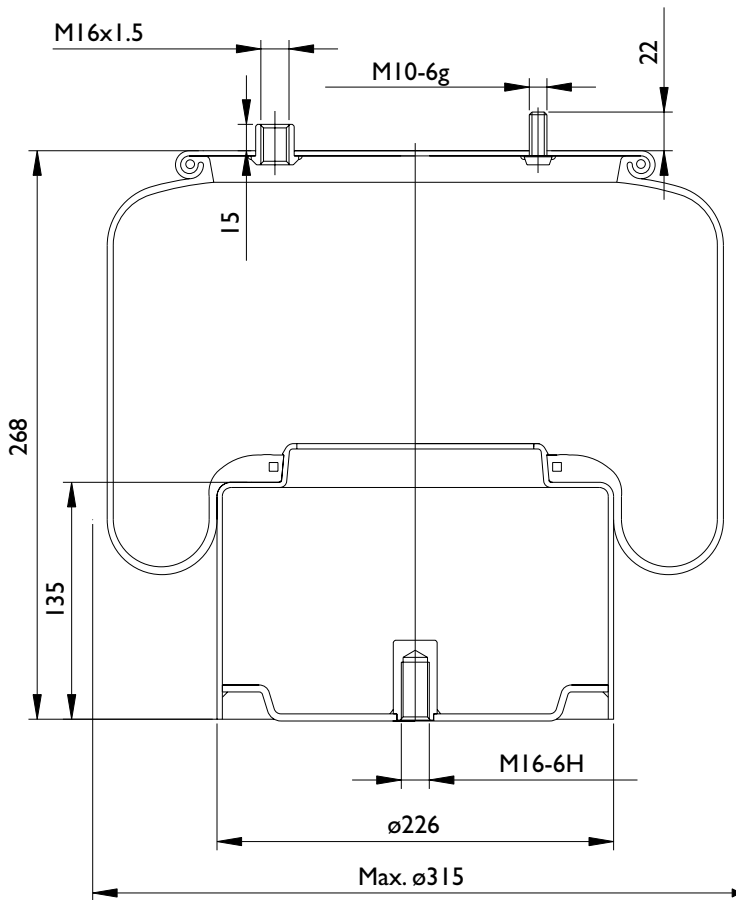

311008 Vista dall'alto

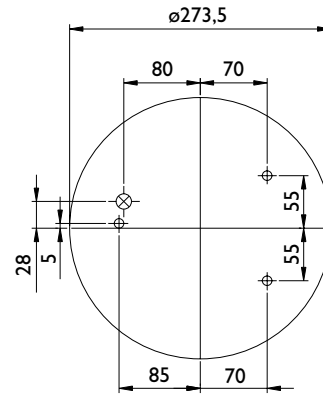

312037 Vista dal basso

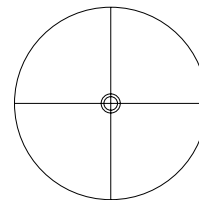

## Applicazioni principali

DAF	388165
DAF	388166

## Lista corrispondenze

CONTITECH	836 MK I
FIRESTONE	
PHOENIX	I DF 25-11
TAURUS	KR 721-06
DUNLOP UK	
DUNLOP F	D 13 B 32
GOODYEAR	I R 12-712
PIRELLI	
GART	

⊗ Entrata aria

⊗ Perno combinato

# MOLLE AD ARIA SEMI-COMLETE



A520041

**AIRTECH® 3836-01**

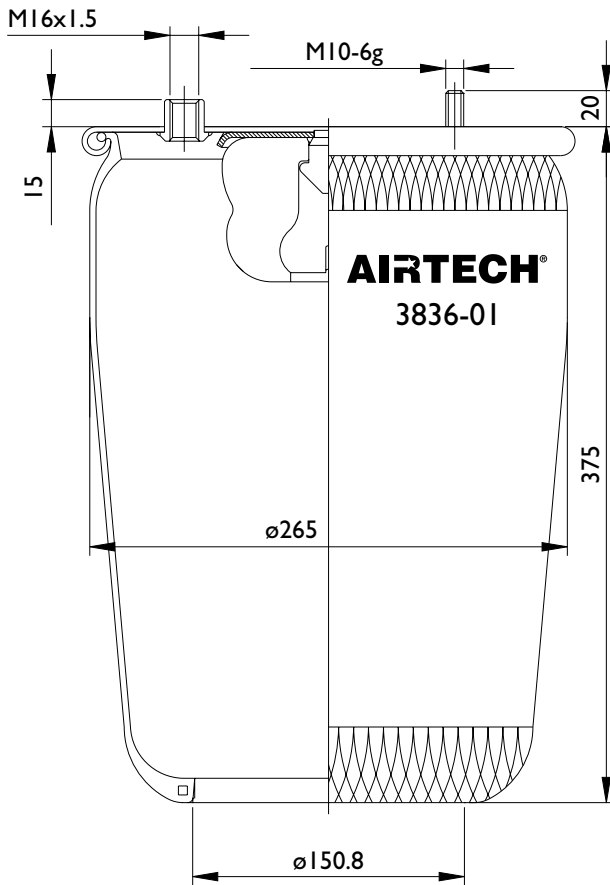

311011 Vista dall'alto

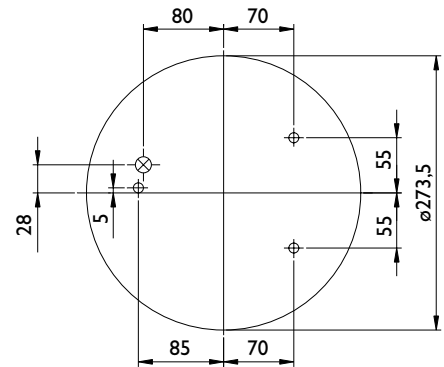

## Applicazioni principali

DAF (con tampone)	0513985

## Lista corrispondenze

CONTITECH	836 MB
FIRESTONE	1T17AR4.5 / W01D080776
PHOENIX	1 DF 25-1
TAURUS	721-01
DUNLOP UK	
DUNLOP F	D13 U32
GOODYEAR	IR12-700
PIRELLI	
GART	



Entrata aria



Perno combinato



A520040

**AIRTECH® 3836-02**

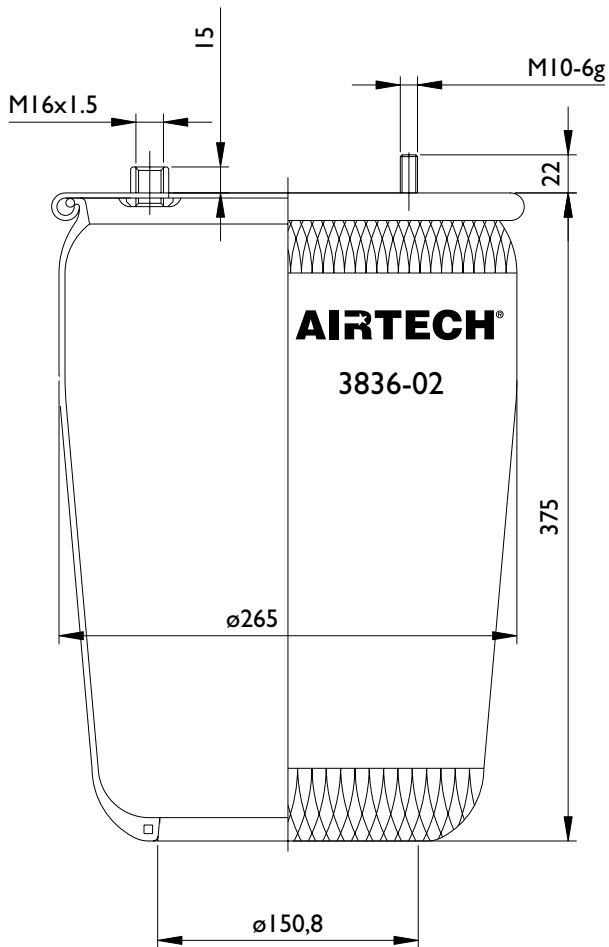

311009 Vista dall'alto

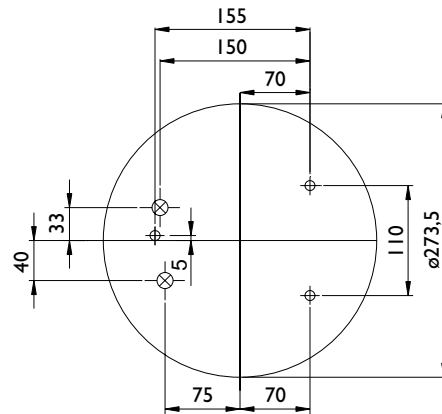

## Applicazioni principali

DAF (con tampone)	0513982

## Lista corrispondenze

CONTITECH	836 M2
FIRESTONE	1T17 AR4.5 / W01D080777
PHOENIX	1 DF 25-3
TAURUS	
DUNLOP UK	
DUNLOP F	D13 U31
GOODYEAR	1 R 12-710
PIRELLI	
GART	

⊗ Entrata aria

⊗ Perno combinato

# MOLLE AD ARIA COMPLETE



A520069C

AIRTECH® 3836-02 K

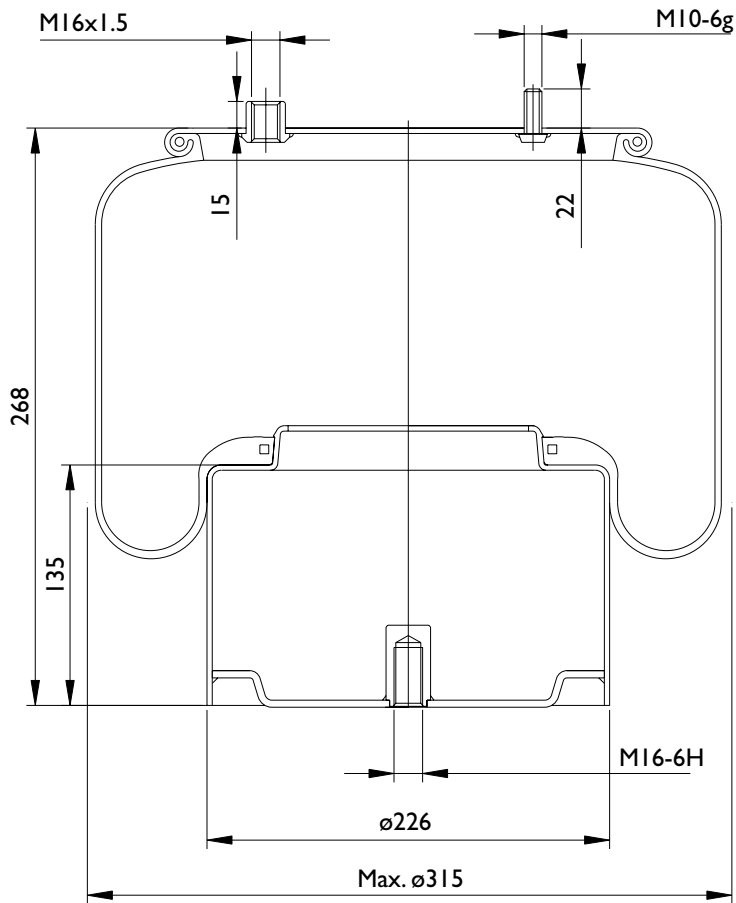

311009 Vista dall'alto

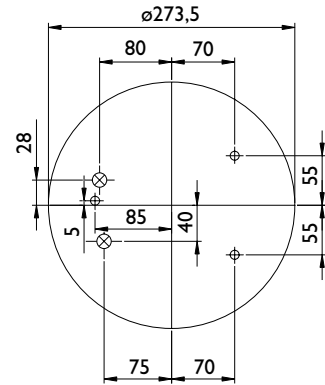

312037 Vista dal basso

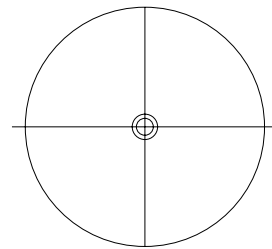

## Applicazioni principali

DAF	388167
DAF	388168
DAF	388169

## Lista corrispondenze

CONTITECH	836 M2 K I
FIRESTONE	IT17AR4,5
PHOENIX	I DF 25-13
TAURUS	KR 721-03
DUNLOP UK	
DUNLOP F	D 13 B 31
GOODYEAR	I R 12-710
PIRELLI	
GART	

⊗ Entrata aria

⊗ Perno combinato

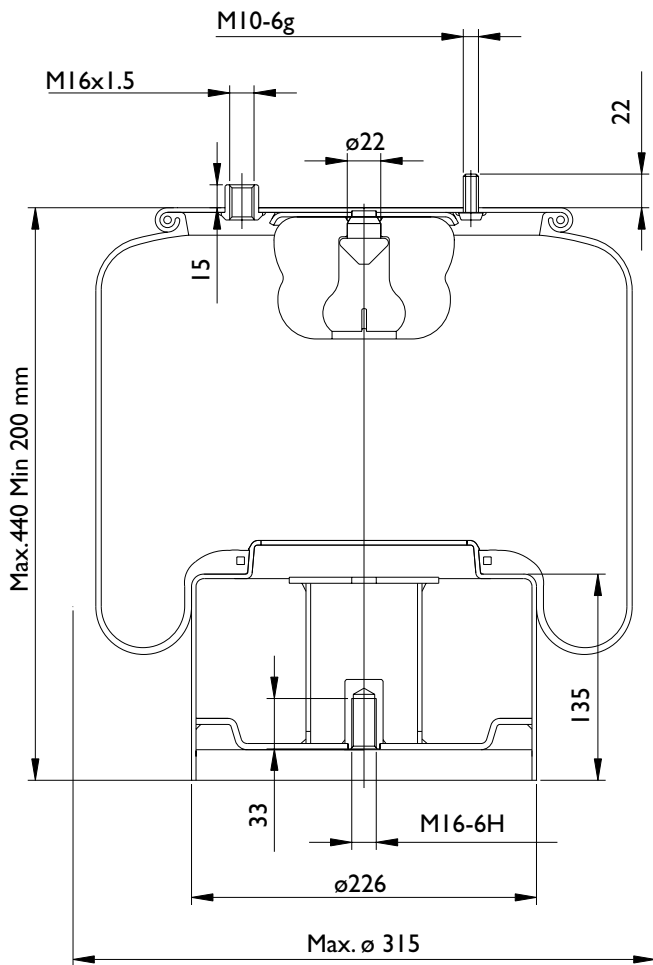

311011 Vista dall'alto

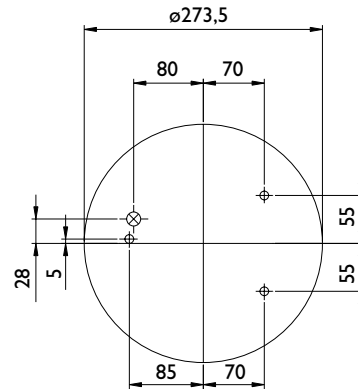

312038 Vista dal basso

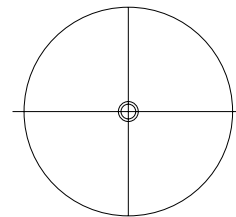

### Applicazioni principali

DAF	377498

### Lista corrispondenze

CONTITECH	836 MBK 4
FIRESTONE	
PHOENIX	
TAURUS	
DUNLOP UK	
DUNLOP F	
GOODYEAR	
PIRELLI	
GART	

⊗ Entrata aria

⊗ Perno combinato



# MOLLE AD ARIA COMPLETE



**AIRTECH® 3836-06 K**

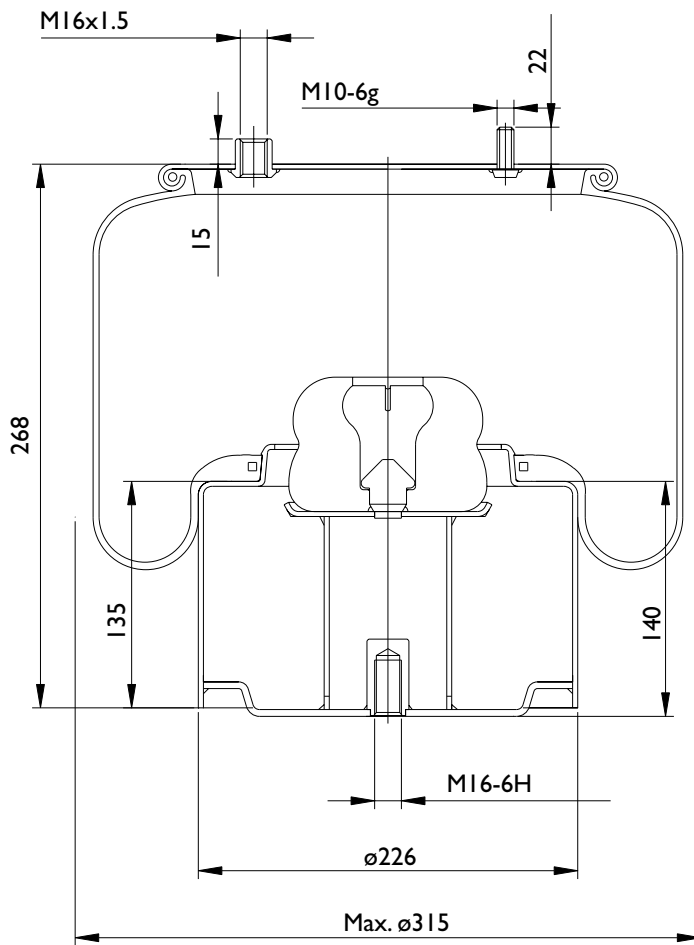

311008 Vista dall'alto

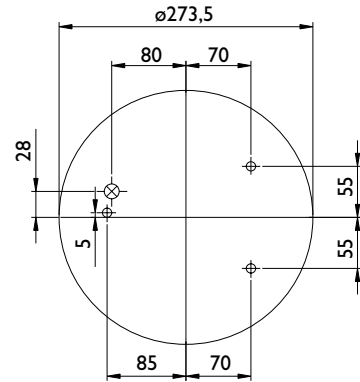

312066 Vista dal basso

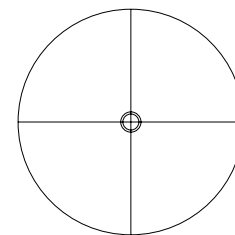

## Applicazioni principali

DAF	526651

## Lista corrispondenze

CONTITECH	836 MBK 6
FIRESTONE	
PHOENIX	
TAURUS	
DUNLOP UK	
DUNLOP F	
GOODYEAR	
PIRELLI	
GART	

⊗ Entrata aria

⊗ Perno combinato

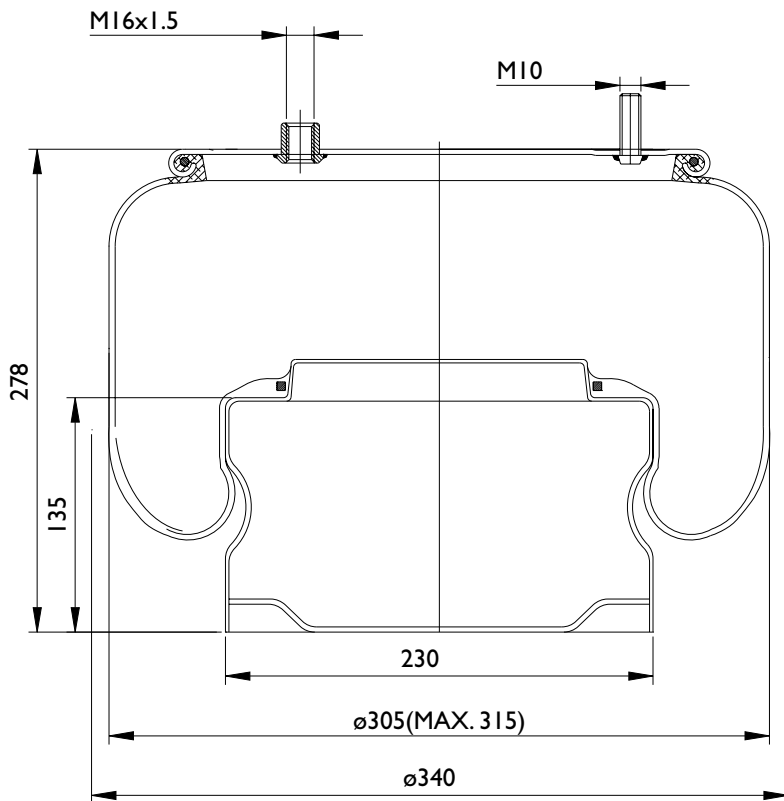

311008 Vista dall'alto

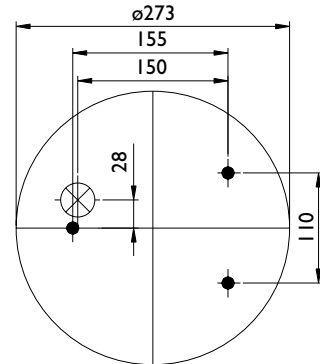

312089 Vista dal basso

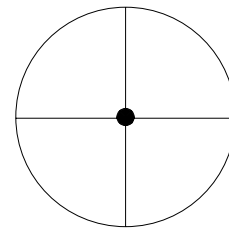

### Applicazioni principali

DAF	297721

### Lista corrispondenze

CONTITECH	836 MK 7
FIRESTONE	1T 17 AR-4.5 D08 8715
PHOENIX	
TAURUS	KR 721-01
DUNLOP UK	
DUNLOP F	D13 B33
GOODYEAR	I R 12-723
PIRELLI	
GART	

⊗ Entrata aria

⊗ Perno combinato

# MOLLE AD ARIA SEMI-COMPLETE



A520029

**AIRTECH® 3881**

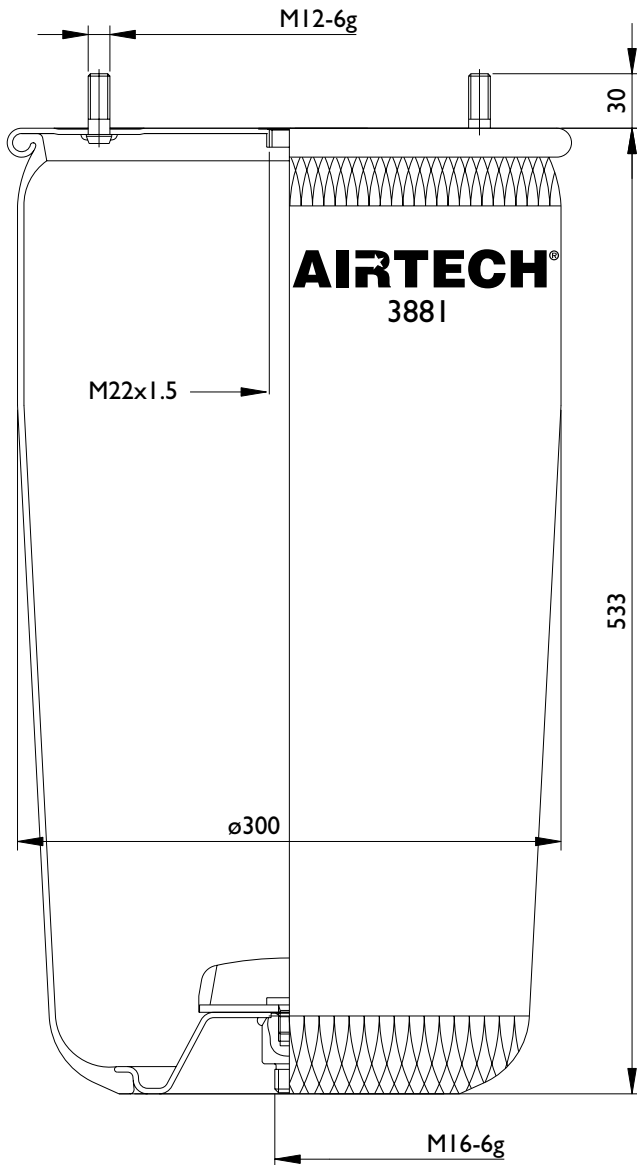

311019 Vista dall'alto

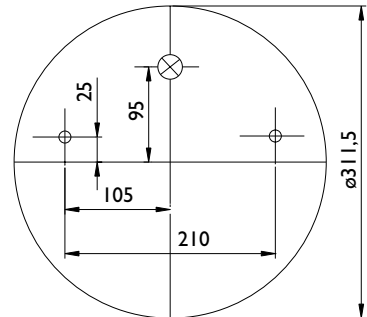

315004 Vista dal basso

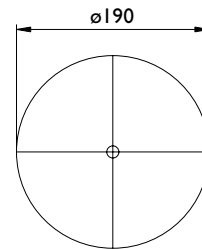

## Applicazioni principali

BPW 36	05.42940.010
BPW	05.42940.020

## Lista corrispondenze

CONTITECH	881 MB
FIRESTONE	I T 66 D-10.8 / W01 M58 8978
PHOENIX	I DK 32-1
TAURUS	KR 836-01
DUNLOP UK	
DUNLOP F	D14 U36
GOODYEAR	I R 14-708
PIRELLI	I TC 360-45 / 204530
GART	C292 292.0.531



Entrata aria



Perno combinato



**A520029C**

**AIRTECH® 3881-01 K**

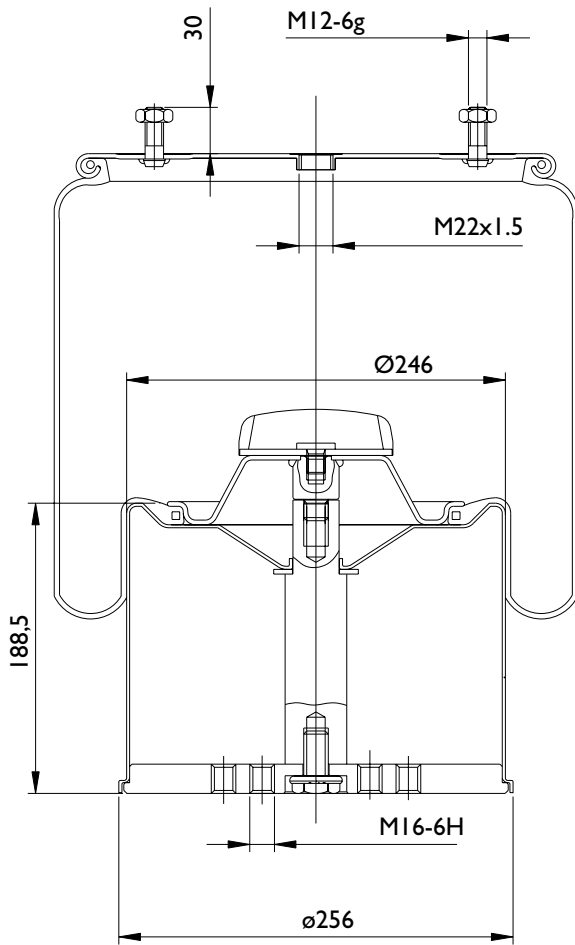

311019 Vista dall'alto

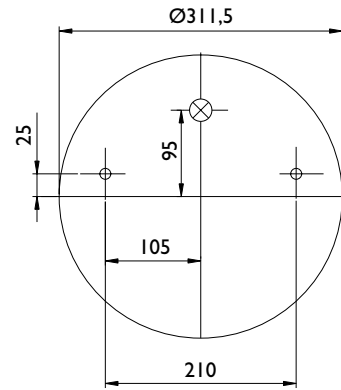

Vista dal basso

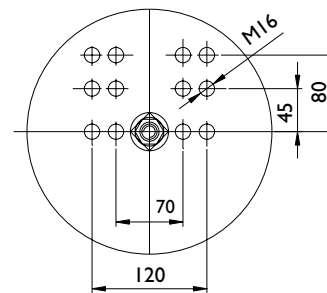

## Applicazioni principali

BPW	05.42940.141
BPW	05.42940.391
BPW	05.42940.471
BPW	05.42940.611
BPW	05.42941.211
BPW 36	05.42941.361

## Lista corrispondenze

CONTITECH	881 MB
FIRESTONE	1 T 66 D-10.8 / W01 M58 8966
PHOENIX	1DK32-1
TAURUS	UR836-01
DUNLOP UK	
DUNLOP F	D 14 B 36
GOODYEAR	1 R 14-703
PIRELLI	1 TC 360-45 / 205 800
GART	C292 292.2.531

⊗ Entrata aria

⊗ Perno combinato

# MOLLE AD ARIA COMPLETE



A520087C

**AIRTECH®** 3881-01 KPP

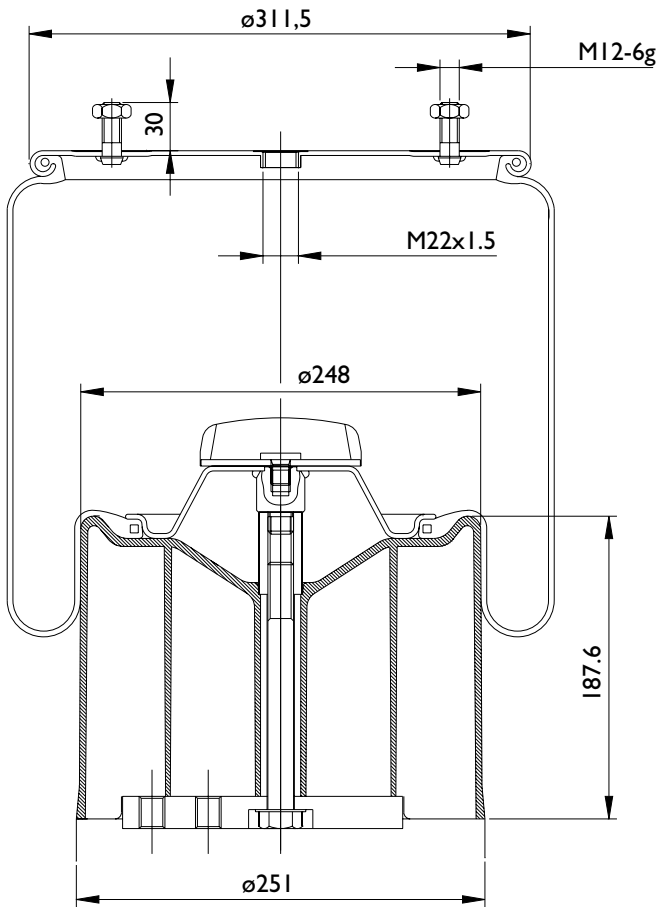

311019 Vista dall'alto

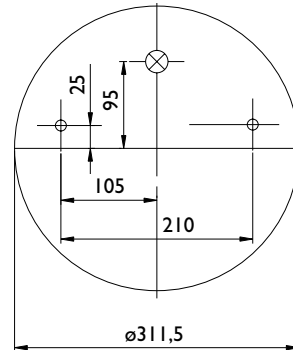

402007 Vista dal basso

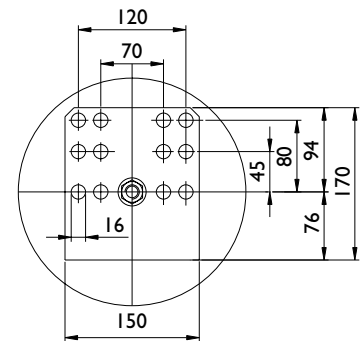

## Applicazioni principali

BPW 36	05.42943.510

## Lista corrispondenze

CONTITECH	881 MB
FIRESTONE	I T 66 D-10.8 / W01 M 58 8966
PHOENIX	
TAURUS	KR836-01
DUNLOP UK	
DUNLOP F	D 14 B 36
GOODYEAR	I R 14-703
PIRELLI	I T C 360-45 / 206357
GART	C292 292.2.531



Entrata aria



Perno combinato

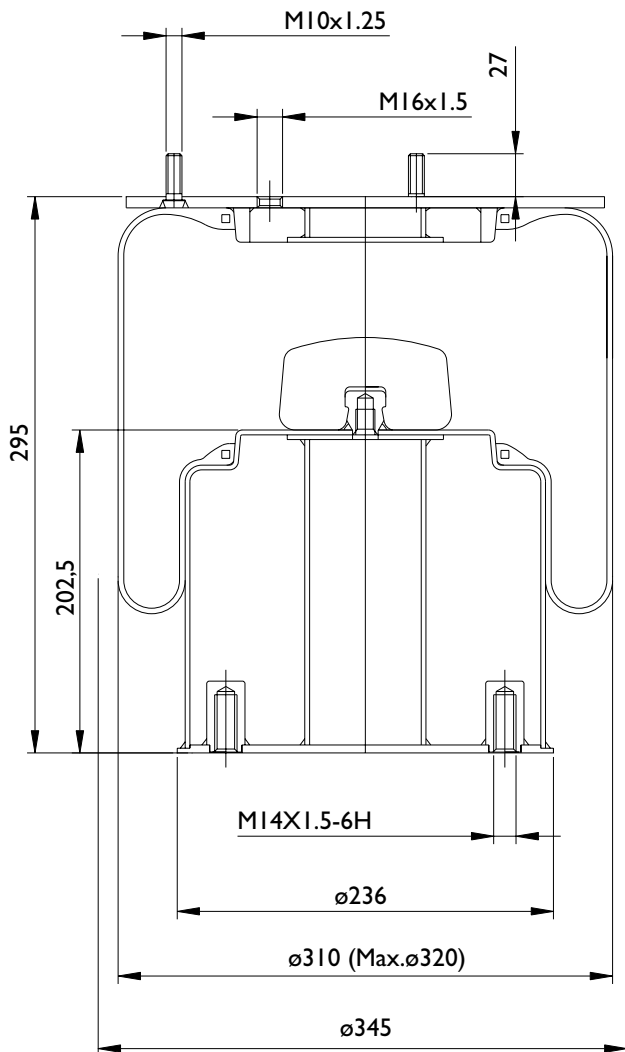

311031 Vista dall'alto

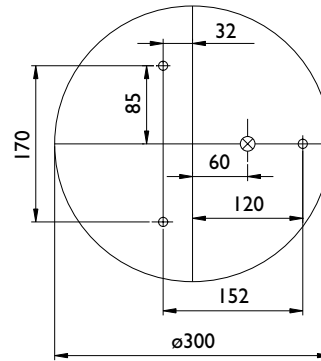

312043 Vista dal basso

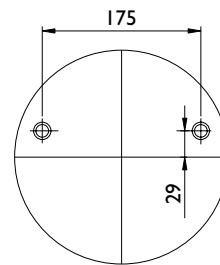

### Applicazioni principali

### Lista corrispondenze

CONTITECH	897 N
FIRESTONE	
PHOENIX	
TAURUS	
DUNLOP UK	
DUNLOP F	
GOODYEAR	
PIRELLI	
GART	

⊗ Entrata aria

⊗ Perno combinato

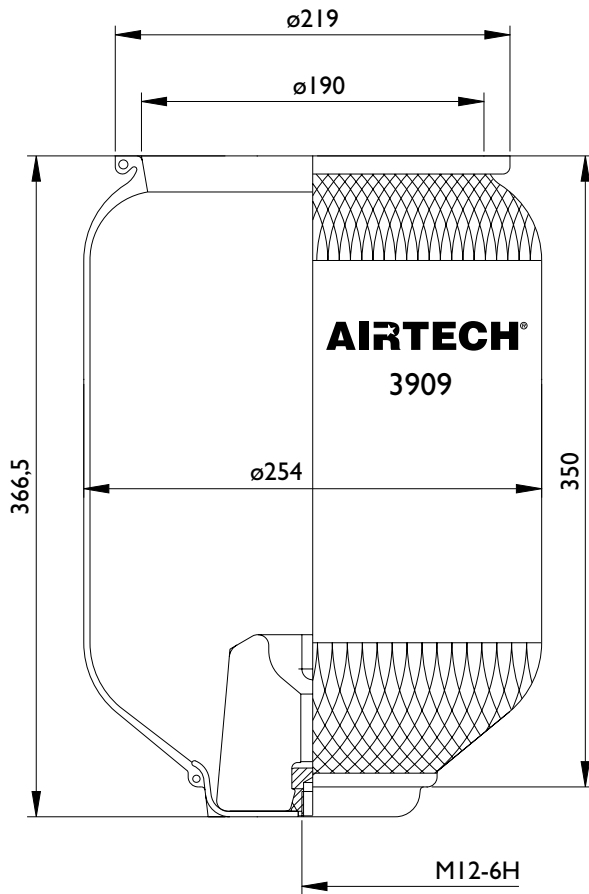

315001 Vista dal basso

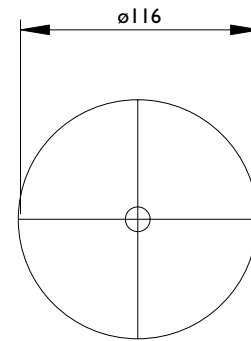

### Applicazioni principali

MAN	814.3601.0050
MAN	814.3601.0054
MAN	814.3601.0073
NEOPLAN	102100500
NEOPLAN	102121500

### Lista corrispondenze

CONTITECH	909 NT
FIRESTONE	I T 15 L-6 / W01 M58 003 I
PHOENIX	I D 23 B-2
TAURUS	B 151
DUNLOP UK	
DUNLOP F	
GOODYEAR	
PIRELLI	
GART	

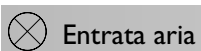

Entrata aria



Perno combinato

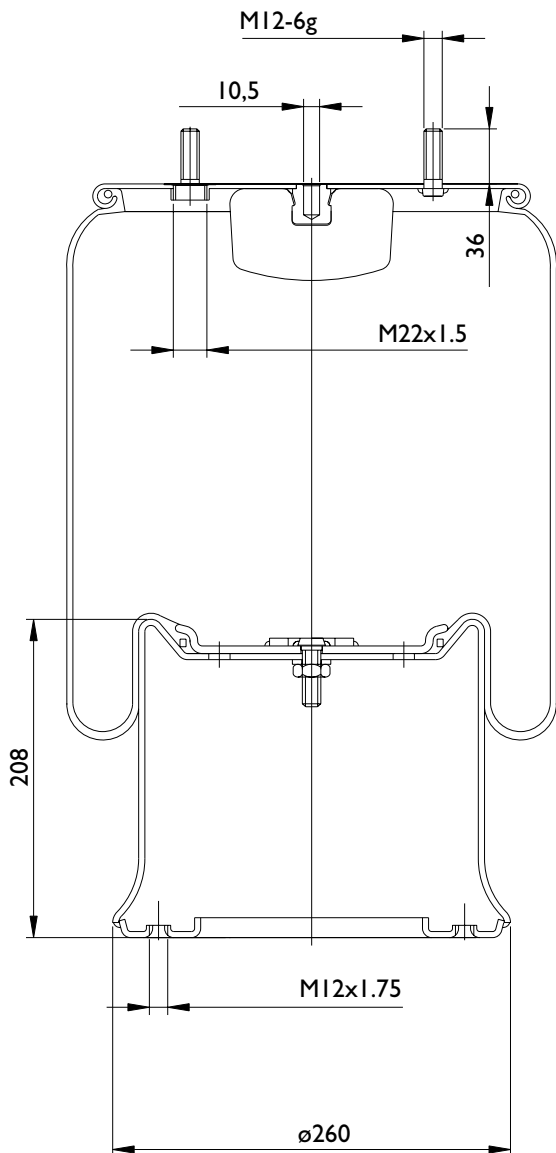
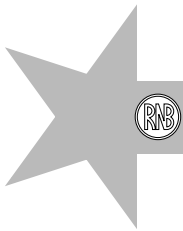

311006 Vista dall'alto

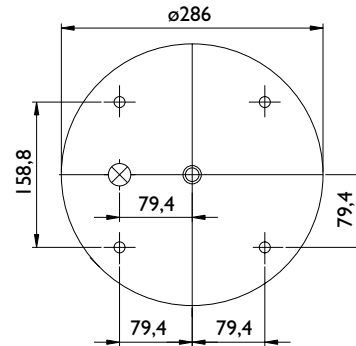

312022 Vista dal basso

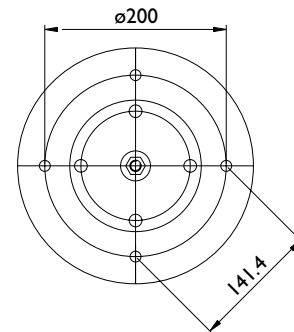

### Applicazioni principali

ROR / MERITOR	21222673
SAF	3.229.0005.01
WEWELER	US96681

### Lista corrispondenze

CONTITECH	912 MB
FIRESTONE	1 T 19 L-14 / W01 M58 7385
PHOENIX	
TAURUS	
DUNLOP UK	
DUNLOP F	D 13 B 14
GOODYEAR	
PIRELLI	1 T 19 E-4
GART	

⊗ Entrata aria

⊗ Perno combinato



# MOLLE AD ARIA SEMI-COMPLETE



A520034

**AIRTECH® 3940**

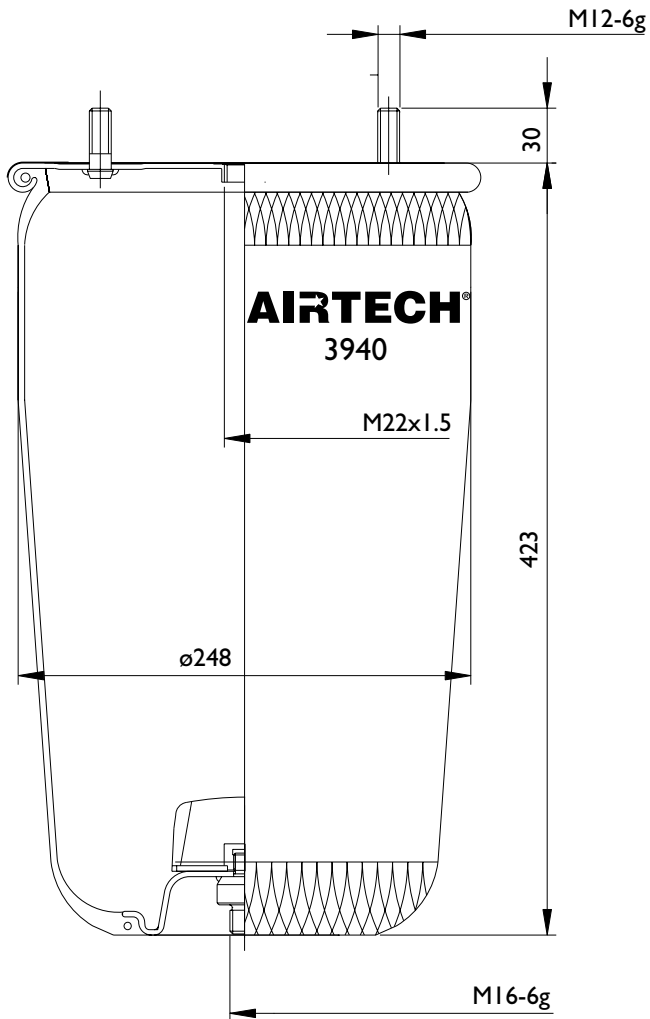

311013 Vista dall'alto

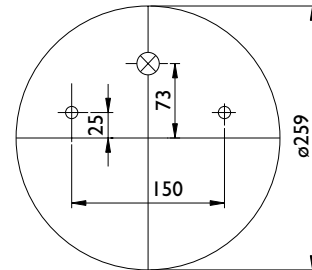

315003 Vista dal basso

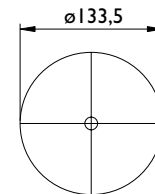

## Applicazioni principali

BPW 30K	05.42940.910
BPW	05.42940.931
BPW	05.42940.941
BPW	05.42941.290
BPW	05.42941.510

## Lista corrispondenze

CONTITECH	940 MB
FIRESTONE	IT17D-4.3 / W01 M58 8613
PHOENIX	I DK 21K
TAURUS	KR 732-01
DUNLOP UK	
DUNLOP F	D11 U31
GOODYEAR	I R 11-703
PIRELLI	ITC300-30 205 536
GART	C293/A 293.0.411



Entrata aria



Perno combinato



**A520034C**

**AIRTECH® 3940 K**

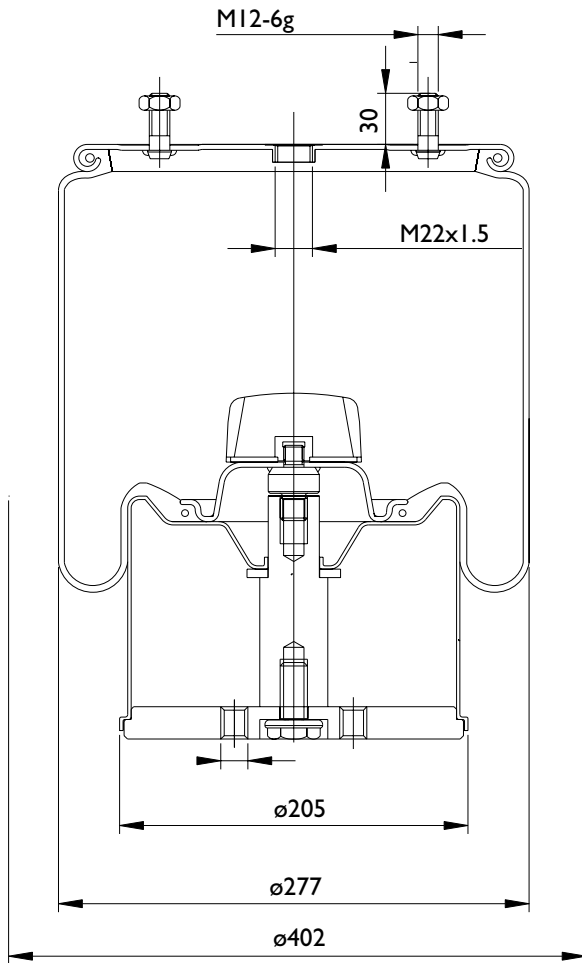

311013 Vista dall'alto

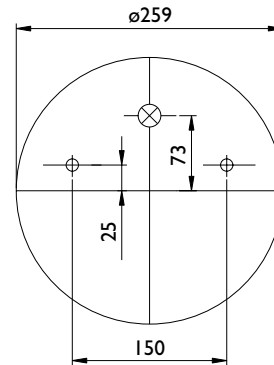

Vista dal basso

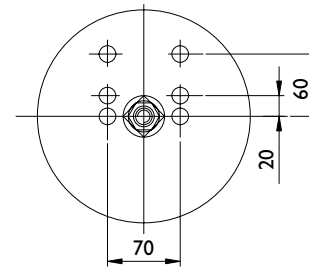

### Applicazioni principali

BPW 30K	05.42940.93 I
BPW	05.42941.23 I

### Lista corrispondenze

CONTITECH	940 MB
FIRESTONE	
PHOENIX	I DK 21K
TAURUS	KR 732-01
DUNLOP UK	
DUNLOP F	D 11 U 31
GOODYEAR	I R 11-763
PIRELLI	
GART	C293/A 293.2.410

⊗ Entrata aria

⊗ Perno combinato

# MOLLE AD ARIA COMPLETE



A520129C

**AIRTECH® 3940 KPP**

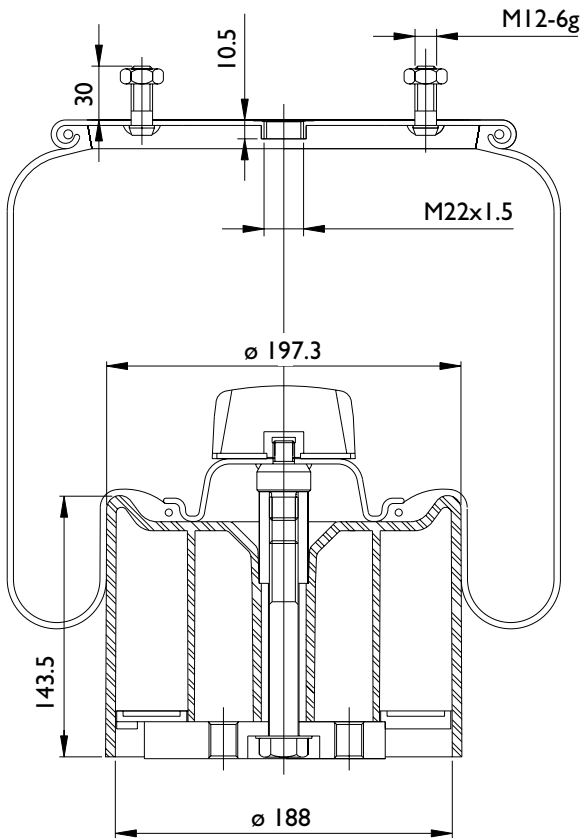

311013 Vista dall'alto

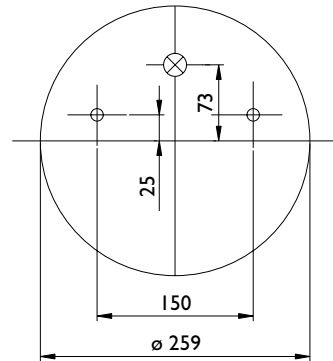

Vista dal basso

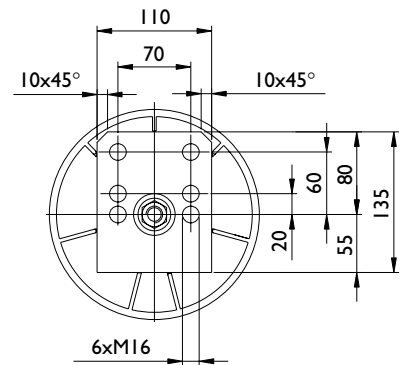

## Applicazioni principali

BPW 30K	05.42943.210

## Lista corrispondenze

CONTITECH	940 MB
FIRESTONE	
PHOENIX	
TAURUS	KR732-01
DUNLOP UK	
DUNLOP F	D11 U31
GOODYEAR	IR11 - 763
PIRELLI	
GART	



Entrata aria



Perno combinato



A520028

**AIRTECH® 3941**

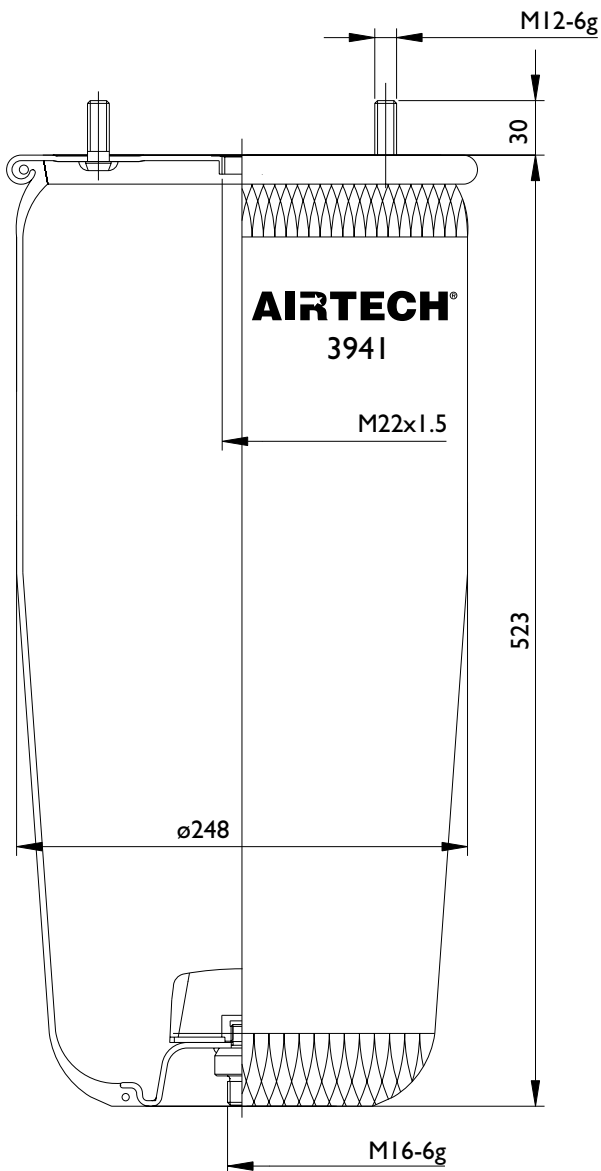

311013 Vista dall'alto

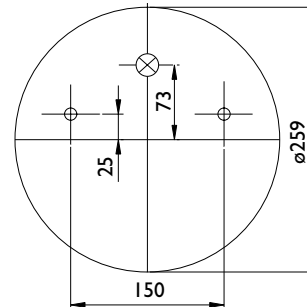

315003 Vista dal basso

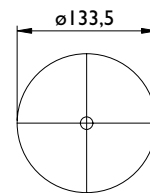

## Applicazioni principali

BPW	05.42491.241
BPW 30	05.42940.030
BPW	05.42940.034
BPW	05.42940.281

## Lista corrispondenze

CONTITECH	941 MB
FIRESTONE	1 T 17 D-8.3 / W01 M58 8620
PHOENIX	1 DK 21
TAURUS	KR 730-01
DUNLOP UK	
DUNLOP F	D11 U30
GOODYEAR	1 R 11-700
PIRELLI	1 TC 300-36 / 204466
GART	C293 293.0.511

⊗ Entrata aria

⊗ Perno combinato

# MOLLE AD ARIA COMPLETE



A520028C

**AIRTECH® 3941 K**

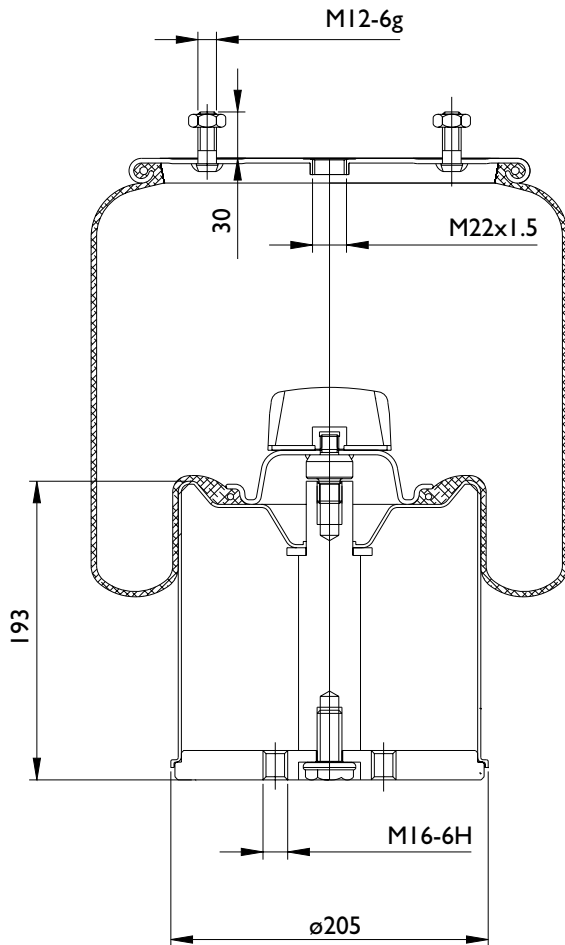

311013 Vista dall'alto

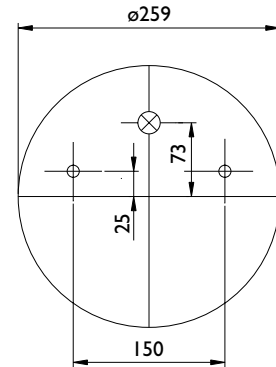

Vista dal basso

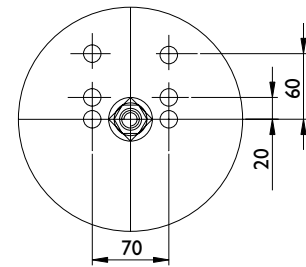

## Applicazioni principali

BPW	05.42940.091
BPW	05.42940.591
BPW 30	05.42941.241
BPW	05.42941.281
BPW	05.42941.371

## Lista corrispondenze

CONTITECH	941 MB
FIRESTONE	I T 17 D-8.3 / W01 M58 8619
PHOENIX	I DK 21
TAURUS	UR 730-01
DUNLOP UK	
DUNLOP F	D II B 32
GOODYEAR	I R II-702
PIRELLI	ITC 300-36 / 205170
GART	C293 293.2.510



Entrata aria



Perno combinato



**A520088C**

**AIRTECH® 3941 KPP**

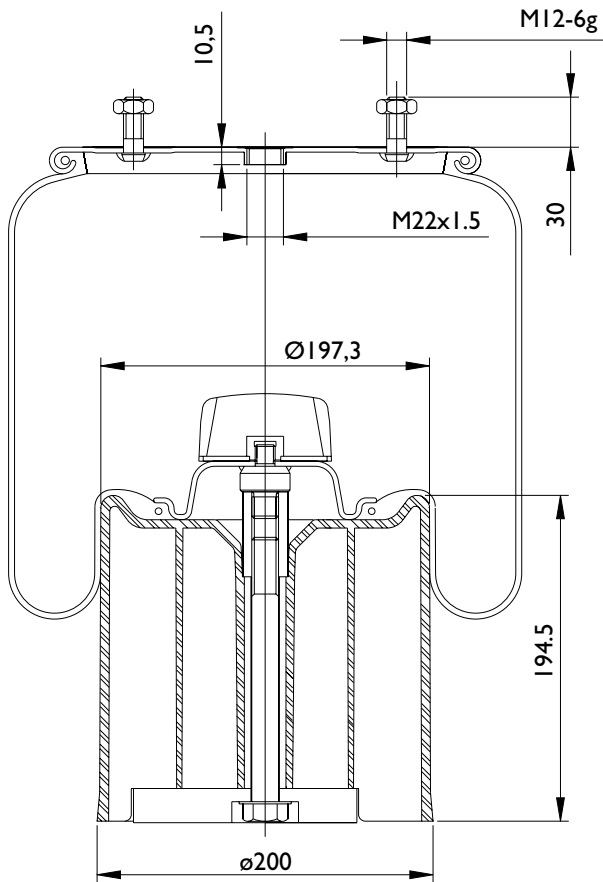

311013 Vista dall'alto

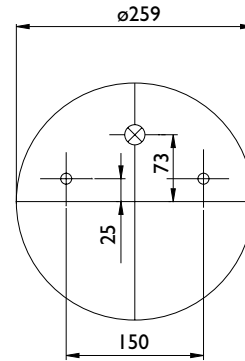

402006 Vista dal basso

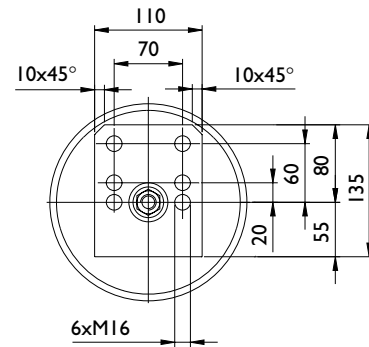

## Applicazioni principali

BPW	05.42940.091
BPW	05.42940.591
BPW	05.42941.241
BPW	05.42941.281
BPW	05.42941.371
BPW 30	05.42943.200

## Lista corrispondenze

CONTITECH	941 MB
FIRESTONE	1 T 17 D-8.3 / W01 M58 8619
PHOENIX	
TAURUS	KR-730-01
DUNLOP UK	
DUNLOP F	D 11 U 30
GOODYEAR	
PIRELLI	1TC300-36 / 206356
GART	

⊗ Entrata aria

⊗ Perno combinato

# MOLLE AD ARIA SEMI-COMLETE

 **A520068**

**AIRTECH® 3942**

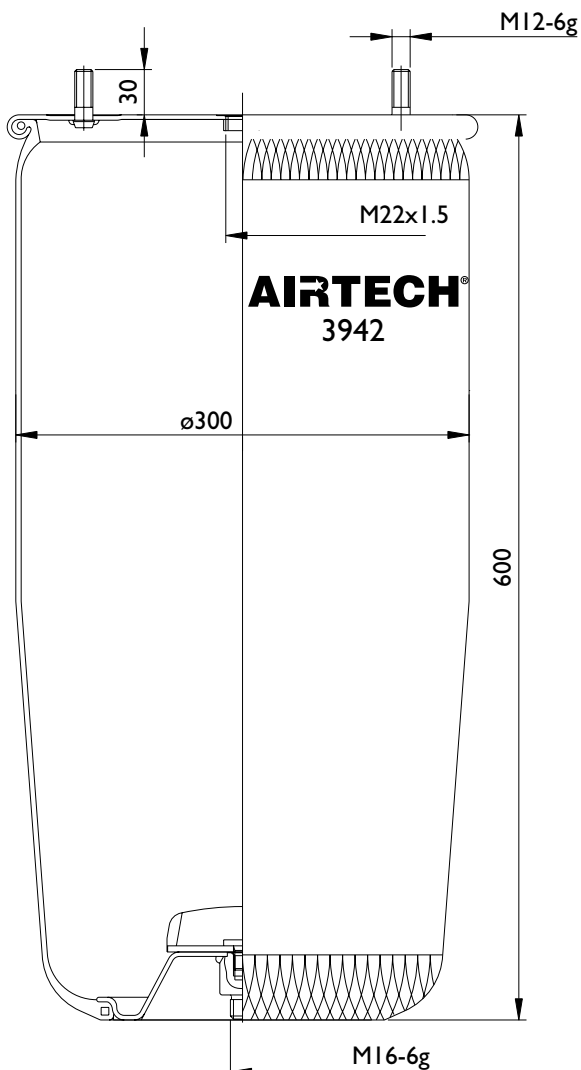

311019 Vista dall'alto

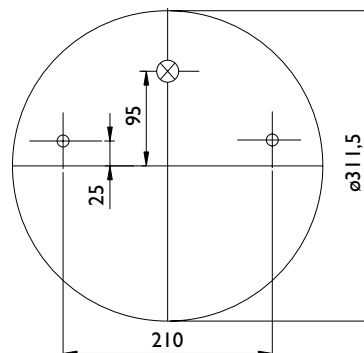

315004 Vista dal basso

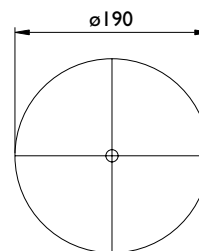



## Applicazioni principali

BPW 36-1	05.42940.050
BPW	05.42940.050
BPW	05.42940.440
BPW	05.42940.580
BPW	05.42941.380
BPW	05.42941.690

## Lista corrispondenze

CONTITECH	942 MB
FIRESTONE	TBA
PHOENIX	
TAURUS	UR 837-01
DUNLOP UK	
DUNLOP F	
GOODYEAR	I R 14-700
PIRELLI	
GART	

 Entrata aria

 Perno combinato



**A520068C**

**AIRTECH® 3942-01 K**

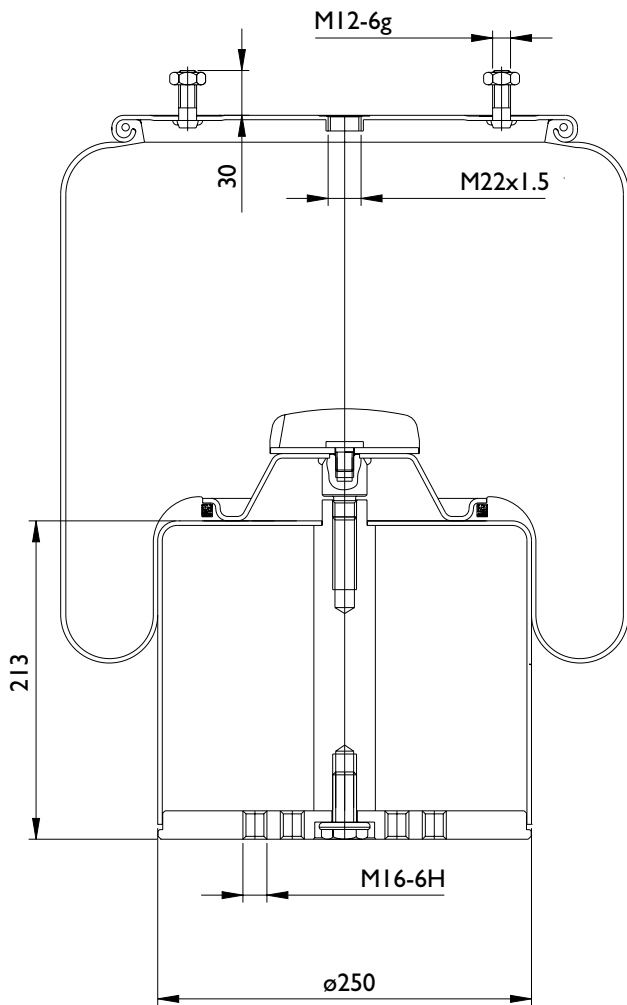

311019 Vista dall'alto

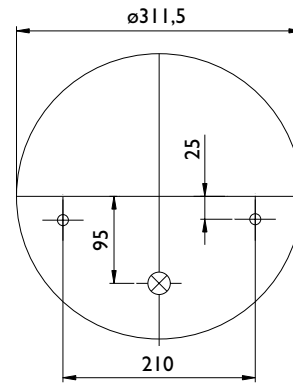

Vista dal basso

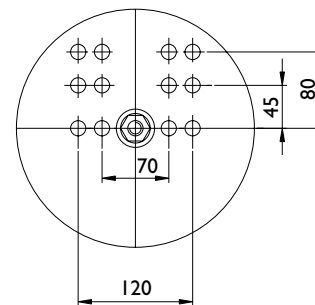

## Applicazioni principali

BPW	05.42940.150
BPW	05.42940.510
BPW 36-I	05.42941.380
BPW	05.42941.690

## Lista corrispondenze

CONTITECH	942 MB
FIRESTONE	
PHOENIX	BPW35-I
TAURUS	UR 837-01
DUNLOP UK	
DUNLOP F	
GOODYEAR	
PIRELLI	
GART	

⊗ Entrata aria

⊗ Perno combinato



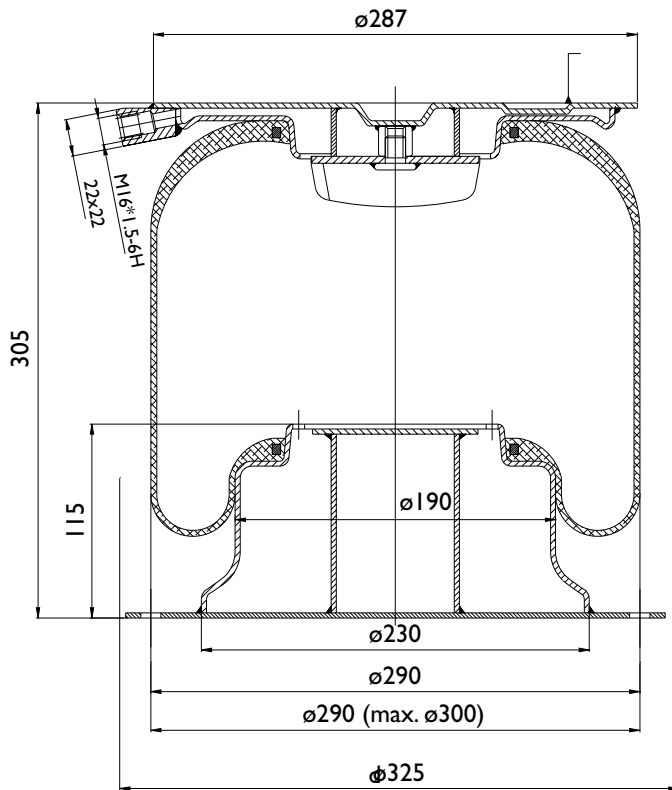

312042 Vista dall'alto

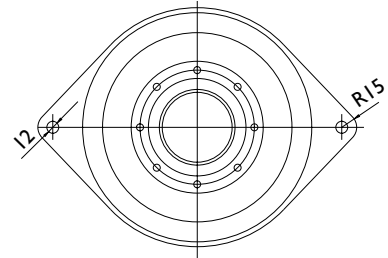

311030 Vista dal basso

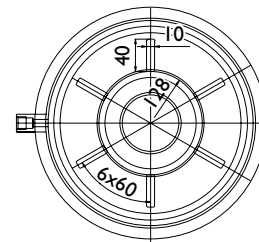

### Applicazioni principali

### Lista corrispondenze

CONTITECH	944 N
FIRESTONE	
PHOENIX	
TAURUS	
DUNLOP UK	
DUNLOP F	
GOODYEAR	
PIRELLI	
GART	

⊗ Entrata aria

⊗ Perno combinato



**A520063**

**AIRTECH® 395 I**

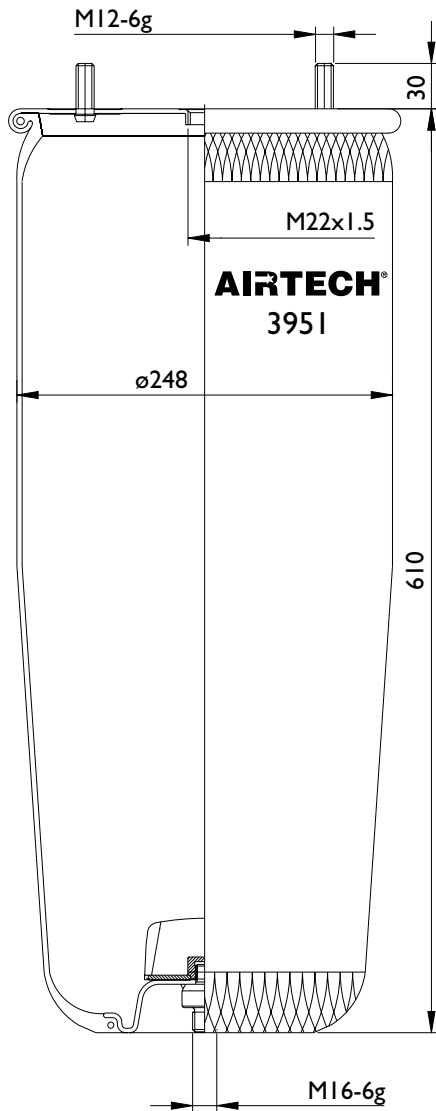

311013 Vista dall'alto

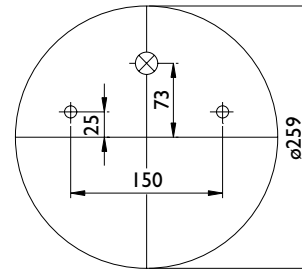

315003 Vista dal basso

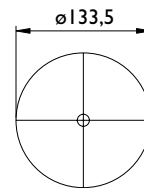

## Applicazioni principali

BPW 30-I	05.42940.720
BPW	05.42940.750
BPW	05.42940.760

## Lista corrispondenze

CONTITECH	95 I MB
FIRESTONE	1 T 17 D-11.8 / W01 M58 862 I
PHOENIX	
TAURUS	
DUNLOP UK	
DUNLOP F	
GOODYEAR	1 R 11 - 704
PIRELLI	
GART	

⊗ Entrata aria

⊗ Perno combinato

# MOLLE AD ARIA COMPLETE



A520147C

**AIRTECH® 30076 K**

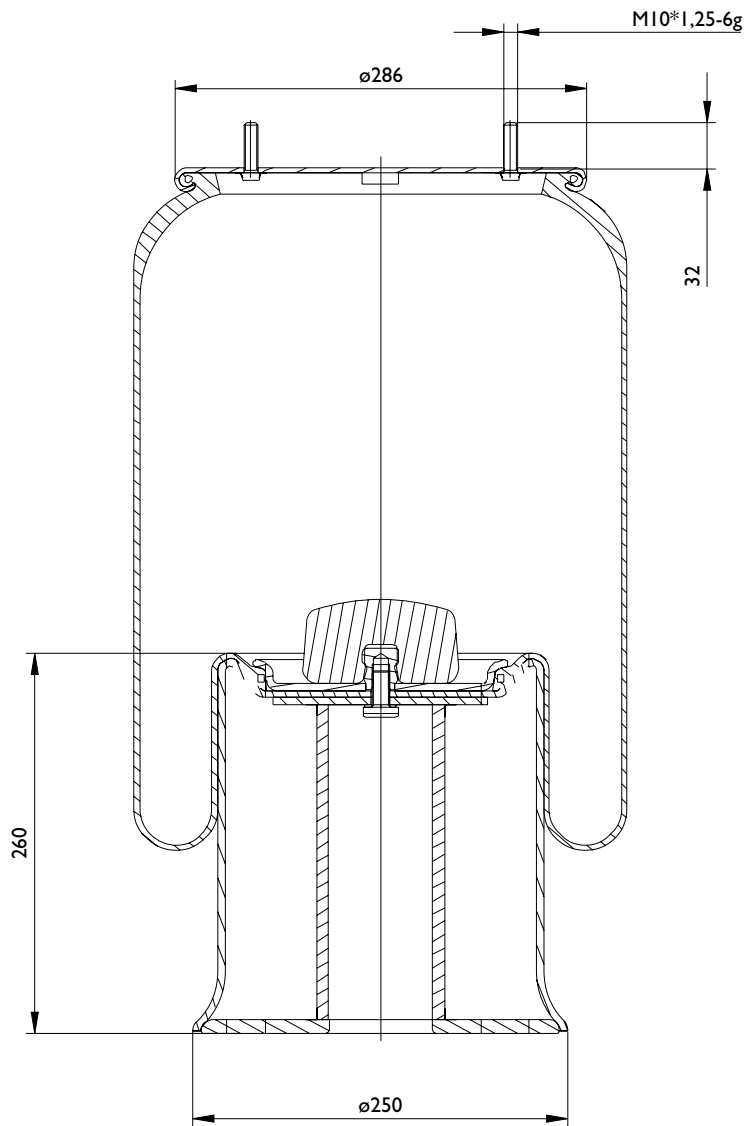

311017 Vista dall'alto

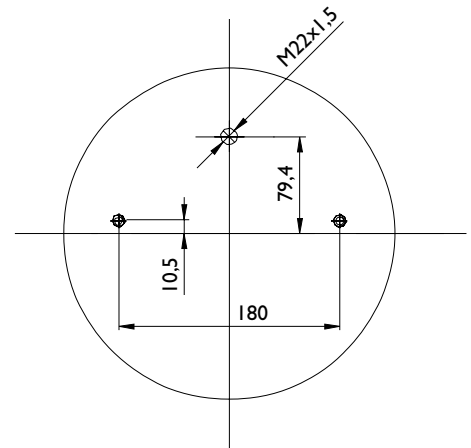

Vista dal basso

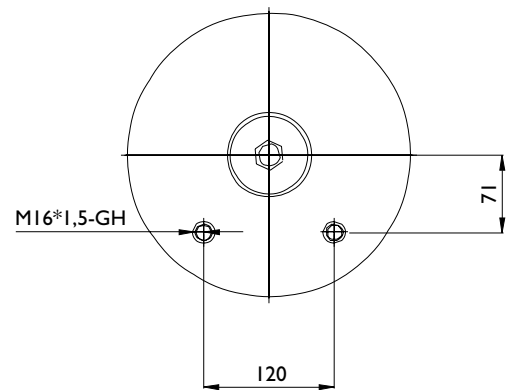

## Applicazioni principali

OMAR	11815
PEZZAIOLI	70100027
ROLFO	112010
ZORZI	1006557

## Lista corrispondenze

CONTITECH	
FIRESTONE	
PHOENIX	
TAURUS	
DUNLOP UK	
DUNLOP F	
GOODYEAR	
PIRELLI	IT 19 E6 / 201715
GART	D287/D 287.2.670

⊗ Entrata aria

⊗ Perno combinato

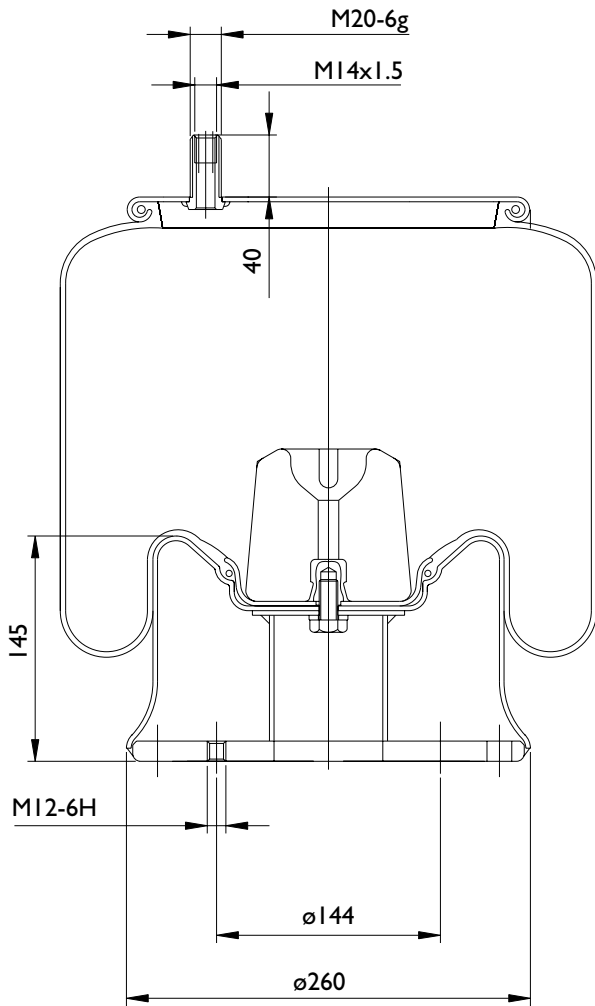

311005 Vista dall'alto

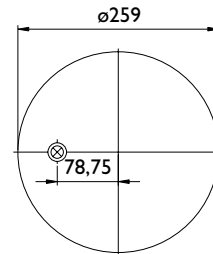

312083 Vista dal basso

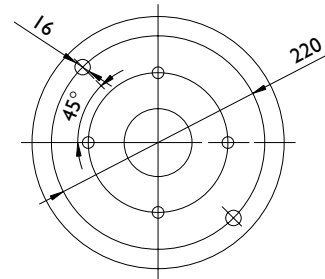

### Applicazioni principali

DISCOS/MERCEDES	A946 328 0401
HENDRICKSON	HS 251 087

### Lista corrispondenze

CONTITECH	
FIRESTONE	I T 17 B-11 /W01 M58 8747
PHOENIX	
TAURUS	
DUNLOP UK	
DUNLOP F	
GOODYEAR	I R 13-150
PIRELLI	
GART	

⊗ Entrata aria

⊗ Perno combinato

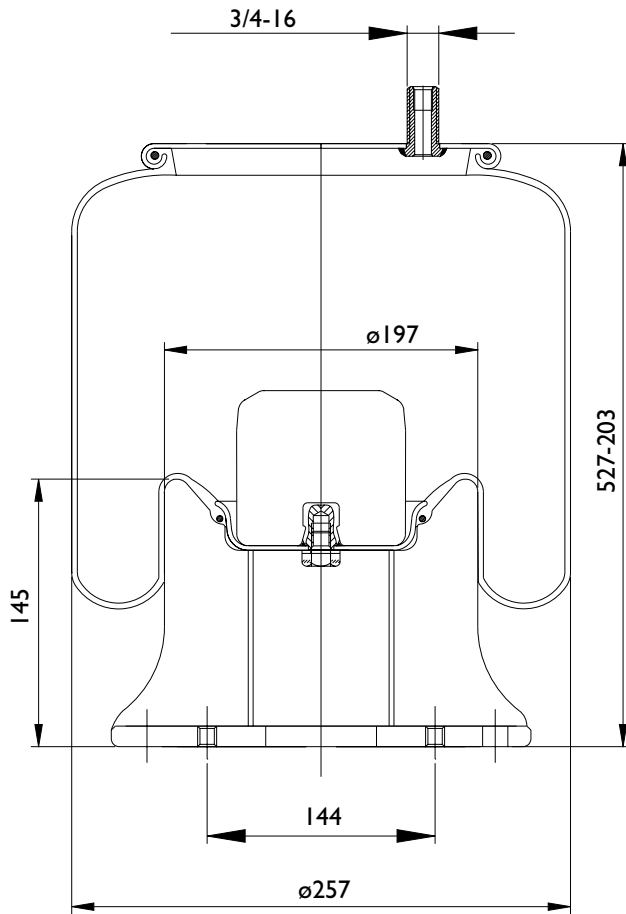

311145 Vista dall'alto

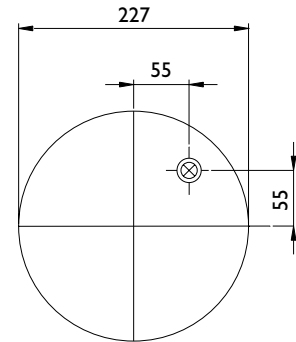

312083 Vista dal basso

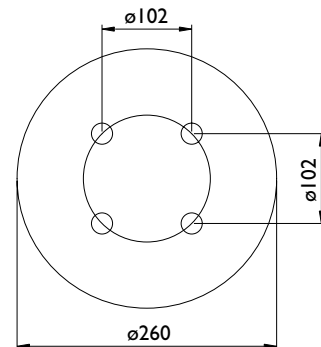

### Applicazioni principali

ERF	I398550
HENDRICKSON	C20127

### Lista corrispondenze

CONTITECH	
FIRESTONE	I T 15VLT-10.5 /W01 358 9580
PHOENIX	
TAURUS	
DUNLOP UK	
DUNLOP F	
GOODYEAR	I R 13-118
PIRELLI	
GART	

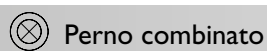

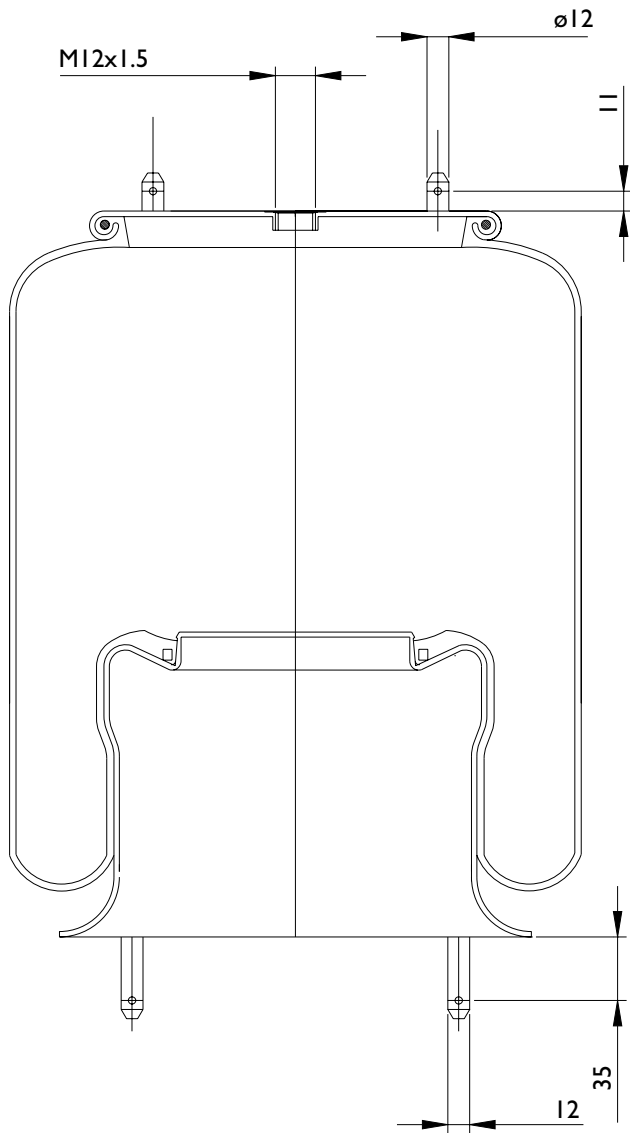
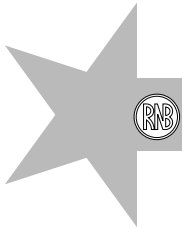

311154 Vista dall'alto

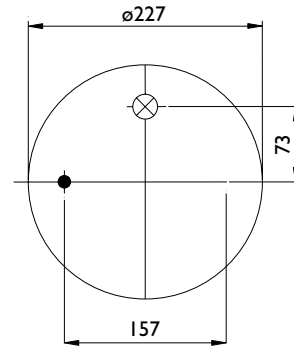

312083 Vista dal basso

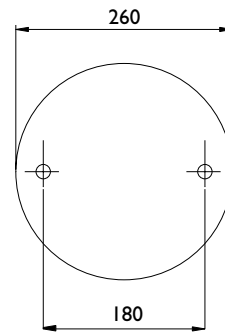

### Applicazioni principali

### Lista corrispondenze

CONTITECH	
FIRESTONE	
PHOENIX	
TAURUS	
DUNLOP UK	
DUNLOP F	
GOODYEAR	
PIRELLI	
GART	

⊗ Entrata aria

⊗ Perno combinato

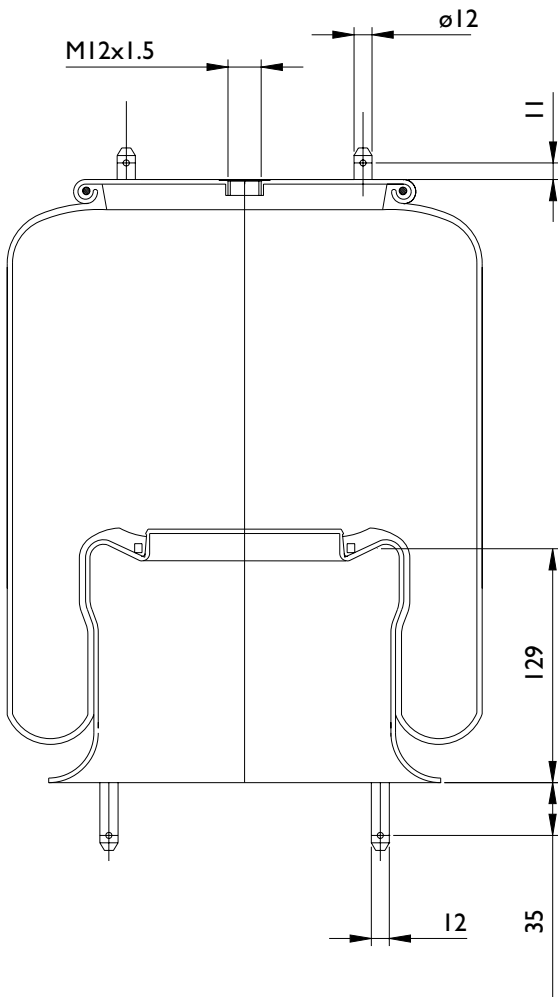

311153 Vista dall'alto

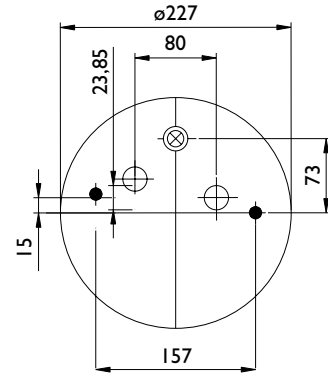

312083 Vista dal basso

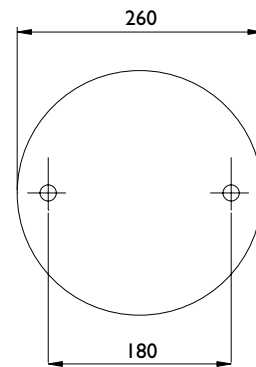

### Applicazioni principali

### Lista corrispondenze

CONTITECH	
FIRESTONE	
PHOENIX	
TAURUS	
DUNLOP UK	
DUNLOP F	
GOODYEAR	
PIRELLI	
GART	

⊗ Entrata aria

⊗ Perno combinato

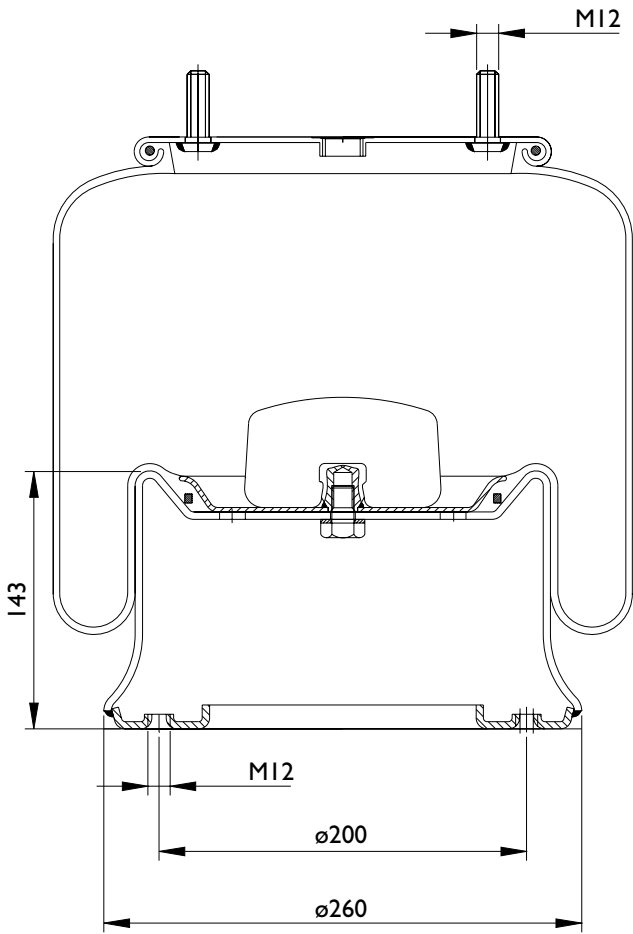

311155 Vista dall'alto

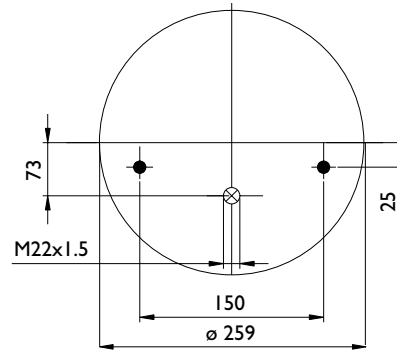

312016 Vista dal basso

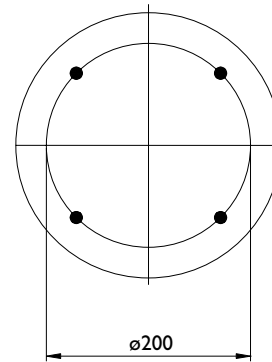

### Applicazioni principali

SAF	2618V

### Lista corrispondenze

CONTITECH	
FIRESTONE	
PHOENIX	
TAURUS	
DUNLOP UK	
DUNLOP F	
GOODYEAR	
PIRELLI	
GART	

⊗ Entrata aria

⊗ Perno combinato



# MOLLE AD ARIA COMPLETE



A520131C

**AIRTECH® 32619 KPP**

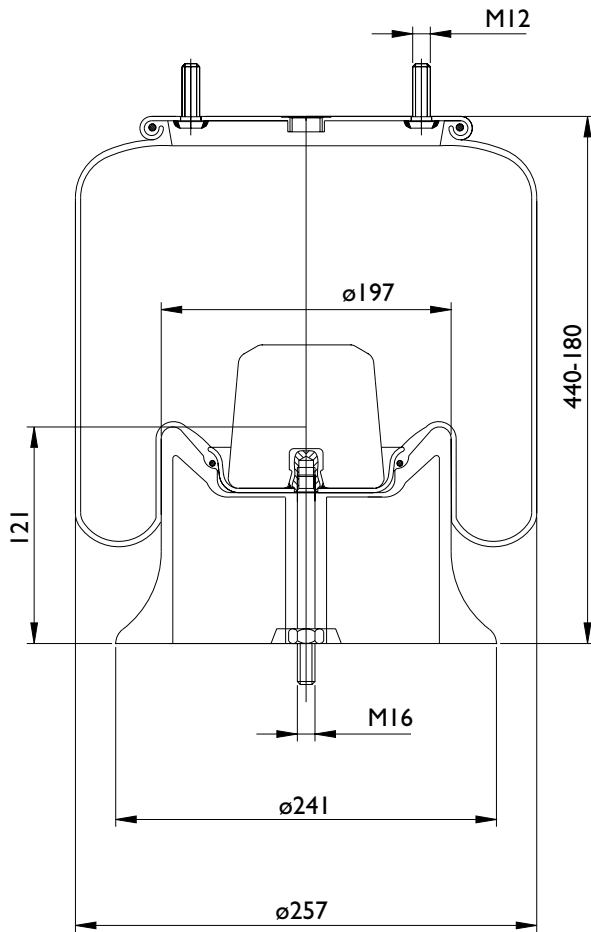

311155 Vista dall'alto

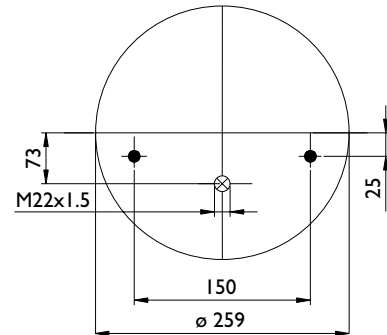

402015 Vista dal basso

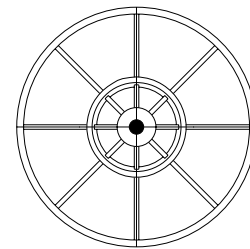

## Applicazioni principali

SAF	2619V
SAF	3.229.0033.00

## Lista corrispondenze

CONTITECH	
FIRESTONE	IT 17 BS-6 / W01 M58 8612
PHOENIX	
TAURUS	
DUNLOP UK	
DUNLOP F	
GOODYEAR	
PIRELLI	I T 300-37 206 585
GART	



Entrata aria



Perno combinato



**A520146C**

**AIRTECH® 32918 K**

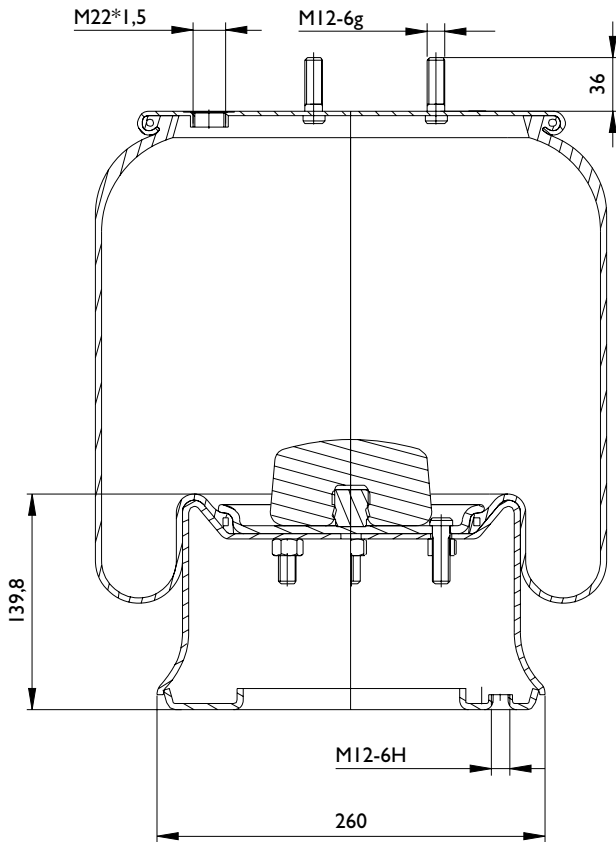

311005 Vista dall'alto

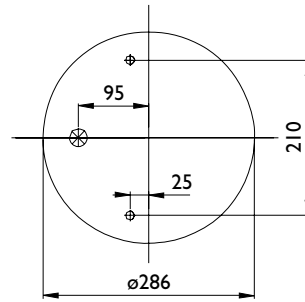

312016 Vista dal basso

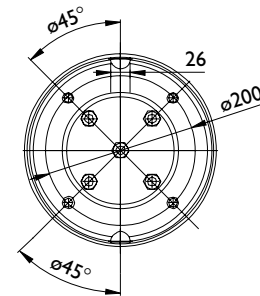

## Applicazioni principali

SAF	2918V
SAF	3229002700

## Lista corrispondenze

CONTITECH	4810 NP 05
FIRESTONE	1T 19 L7 / W01 M58 6338
PHOENIX	
TAURUS	
DUNLOP UK	
DUNLOP F	
GOODYEAR	
PIRELLI	1T 19 EI / 205456
GART	

⊗ Entrata aria

⊗ Perno combinato

# MOLLE AD ARIA COMPLETE



A520132C

**AIRTECH® 32926 K**

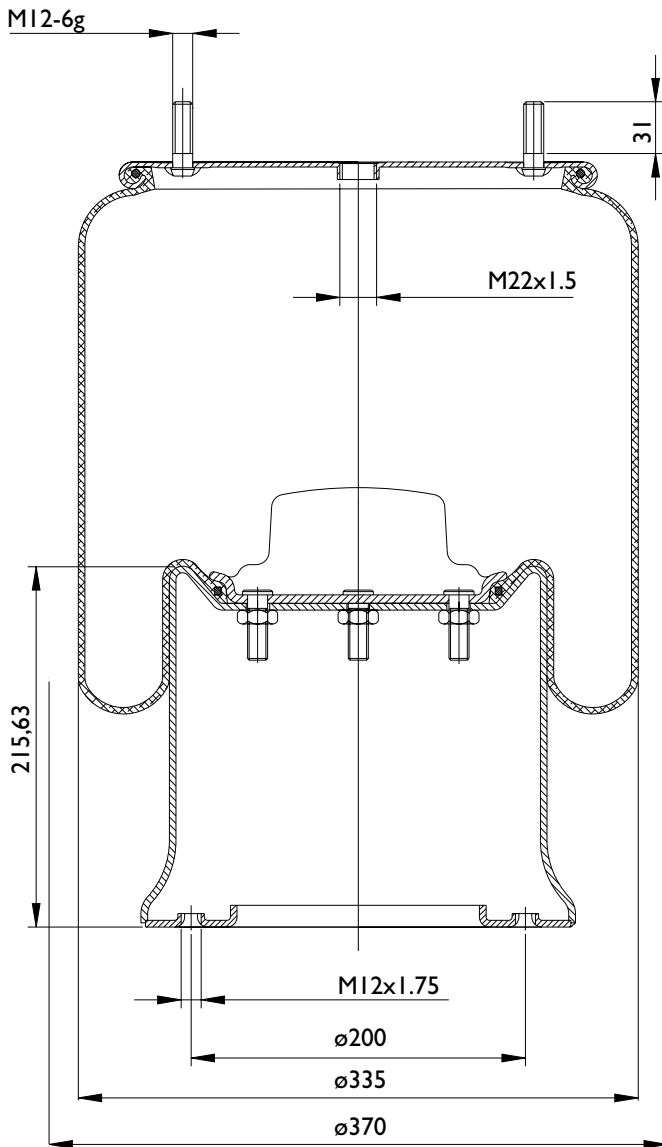

311005 Vista dall'alto

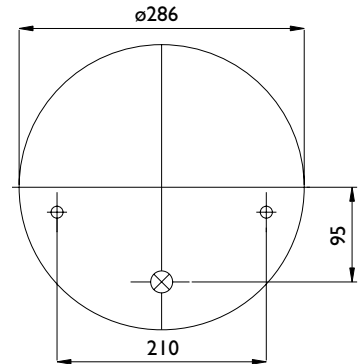

312079 Vista dal basso

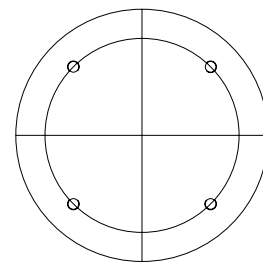

## Applicazioni principali

SAF	2926V
SAF	3.229.0030.00
SAF	3.229.2630.00

## Lista corrispondenze

CONTITECH	
FIRESTONE	
PHOENIX	
TAURUS	
DUNLOP UK	
DUNLOP F	
GOODYEAR	I R 14-728
PIRELLI	I T 19E-2L 206 333
GART	



Entrata aria



Perno combinato



**A520062**

**AIRTECH® 34004**

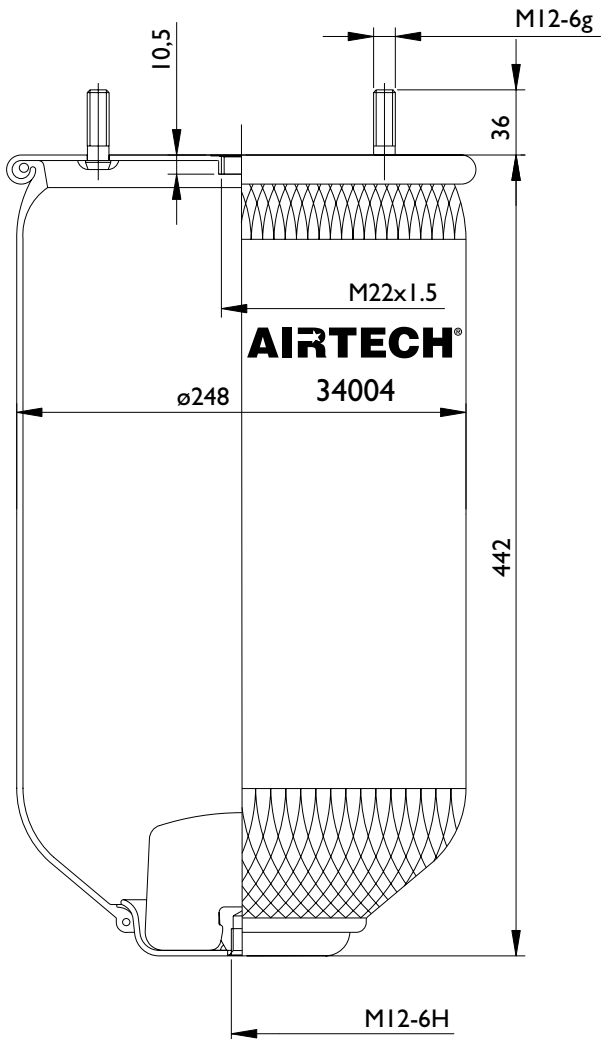

311012 Vista dall'alto

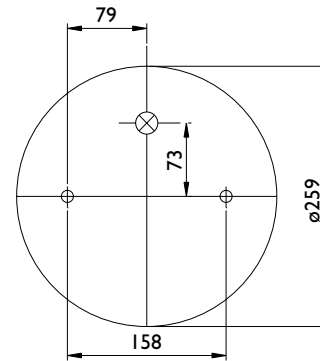

315001 Vista dal basso

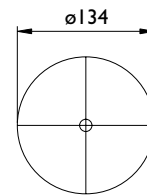

## Applicazioni principali

SAF	3.229.0007.00
SAF	3.229.0007.02
SAF	2.229.2107.00

## Lista corrispondenze

CONTITECH	4004 NP 02
FIRESTONE	1T17BS6 / W01 M58 6366
PHOENIX	
TAURUS	
DUNLOP UK	
DUNLOP F	
GOODYEAR	I R 11-705
PIRELLI	1T300-37
GART	

⊗ Entrata aria

⊗ Perno combinato

# MOLLE AD ARIA COMPLETE



A520062C

AIRTECH® 34004 K

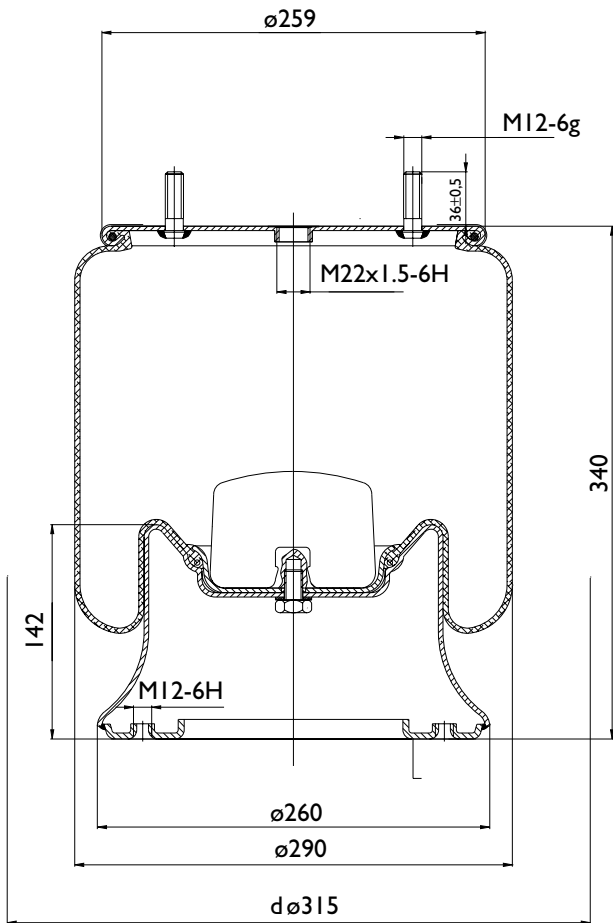

311012 Vista dall'alto

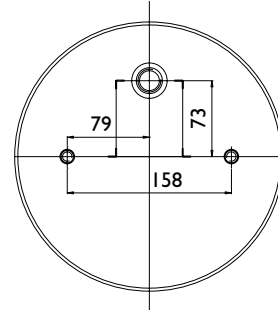

312011 Vista dal basso

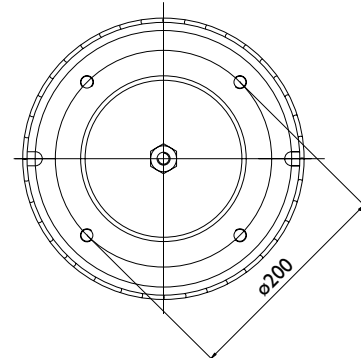

## Applicazioni principali

SAF	2.229.0007.00

## Lista corrispondenze

CONTITECH	4004 NP 03
FIRESTONE	I T 17 BS-6/W01 M58 6366
PHOENIX	I DK 22 E-5
TAURUS	K 505-27 SM
DUNLOP UK	
DUNLOP F	D 12 B 13
GOODYEAR	I R 11-706
PIRELLI	I T 323-33 / 97722
GART	



Entrata aria



Perno combinato



**A520090C**

**AIRTECH® 34004 KPP**

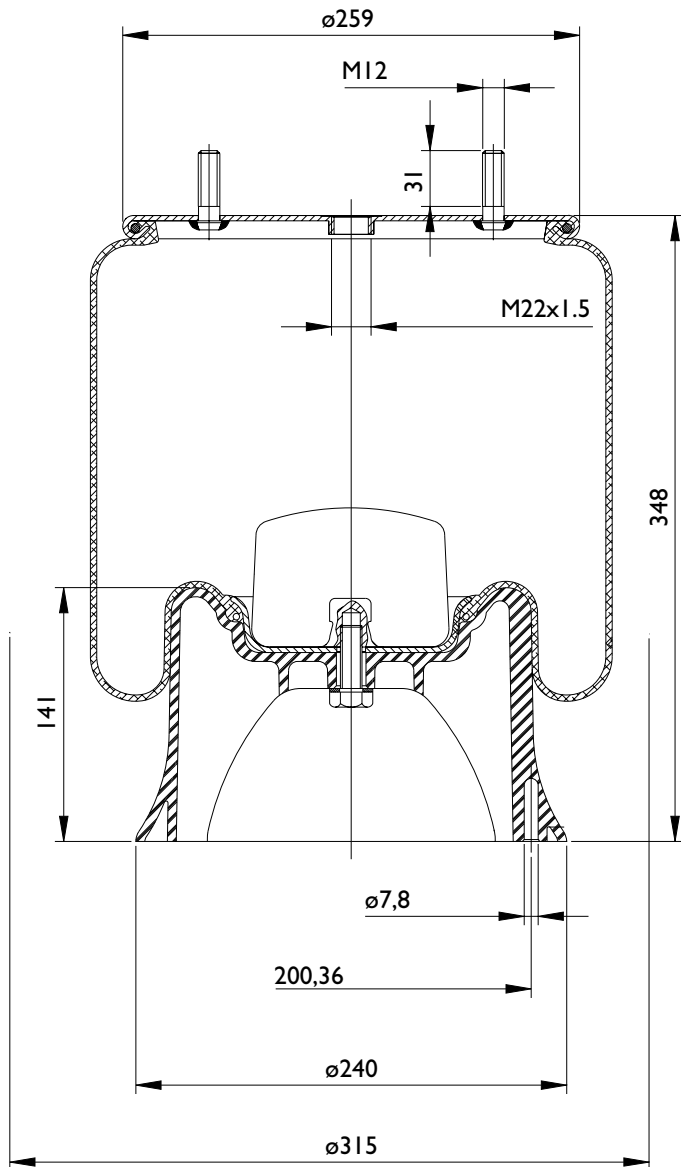

311012 Vista dall'alto

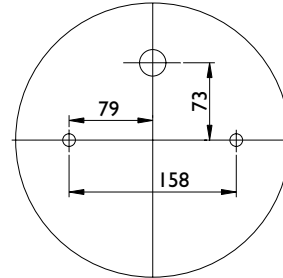

402009 Vista dal basso

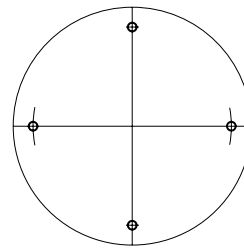

## Applicazioni principali

SAF	3.229.0007.02
SAF	4.284.3003.01

## Lista corrispondenze

CONTITECH	4004 NP 03
FIRESTONE	I T I7 BS-6 / W01 M58 6366
PHOENIX	IDK22E-8
TAURUS	
DUNLOP UK	
DUNLOP F	D12B13
GOODYEAR	I R 11-713
PIRELLI	I T 300-37 / 203715
GART	

⊗ Entrata aria

⊗ Perno combinato

# MOLLE AD ARIA SEMI-COMLETE



A520055

**AIRTECH® 34022**

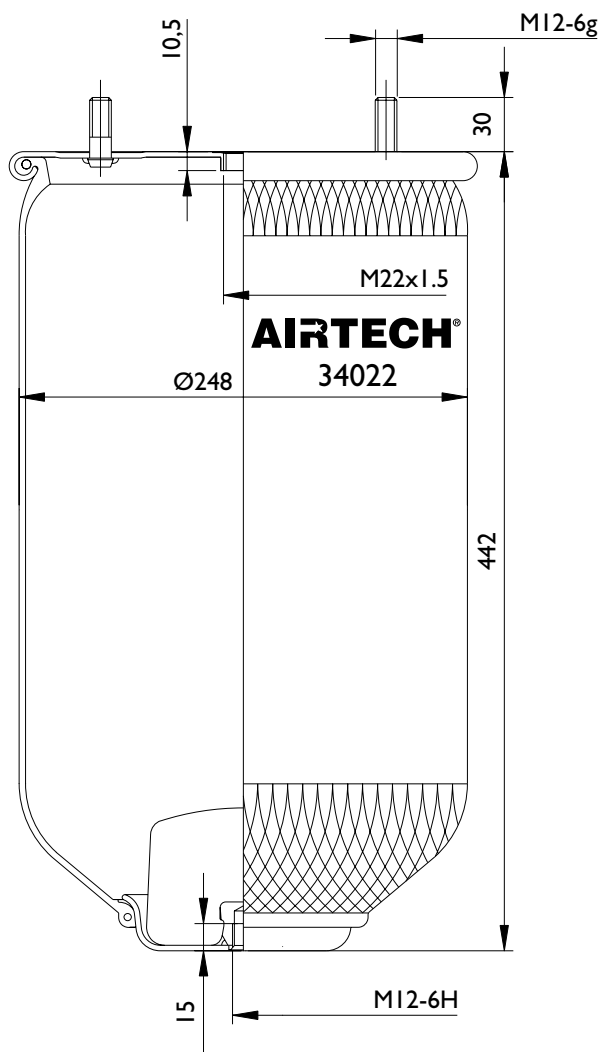

311013 Vista dall'alto

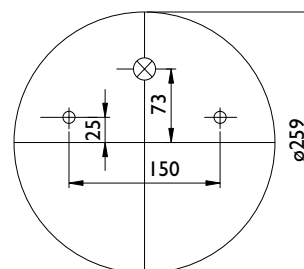

315001 Vista dal basso

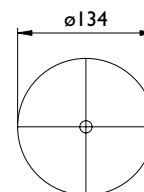

## Applicazioni principali

SAF	3.229.0029.00

## Lista corrispondenze

CONTITECH	4022 NP 02
FIRESTONE	I T 17 BS-6/W01 M58 0756
PHOENIX	
TAURUS	
DUNLOP UK	
DUNLOP F	
GOODYEAR	I R 11-709
PIRELLI	
GART	

⊗ Entrata aria

⊗ Perno combinato

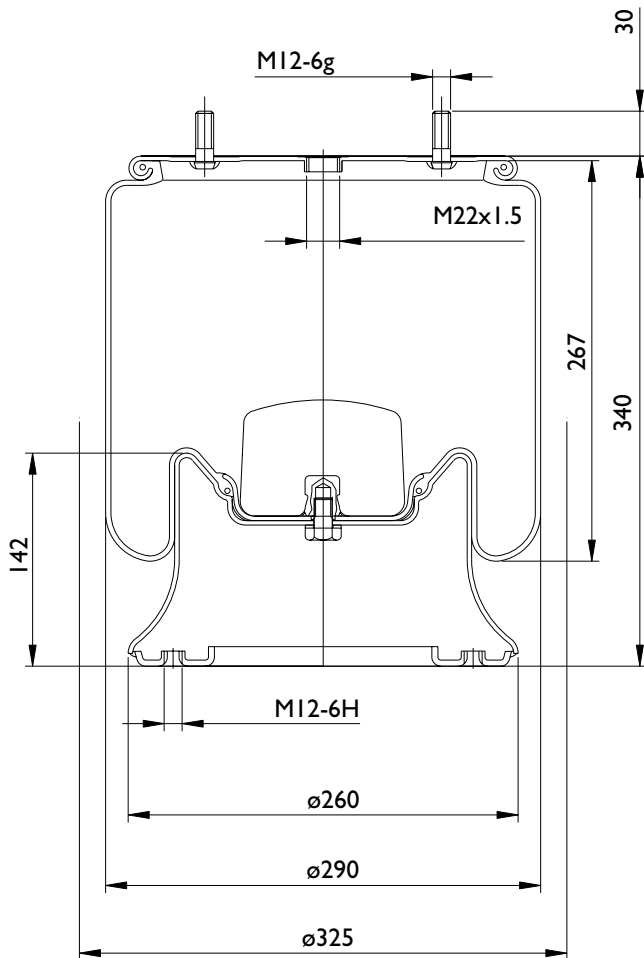

311013 Vista dall'alto

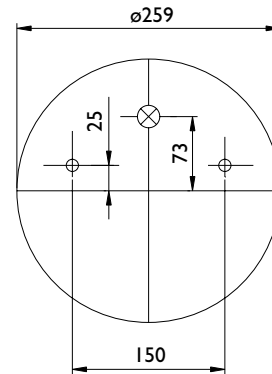

312011 Vista dal basso

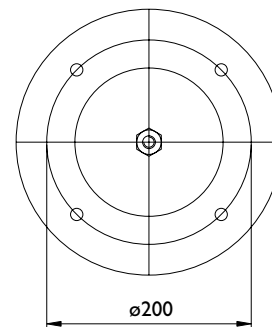

### Applicazioni principali

SAF	3.229.0029.00
SAF	2618V

### Lista corrispondenze

CONTITECH	4022 NP 03
FIRESTONE	1 T 17 BS-6 / W01 M58 6367
PHOENIX	
TAURUS	KR 725-28
DUNLOP UK	
DUNLOP F	D 13 B 25
GOODYEAR	1 R 11-710
PIRELLI	
GART	

⊗ Entrata aria

⊗ Perno combinato



# MOLLE AD ARIA COMPLETE



A520095C

AIRTECH® 34022 KPP

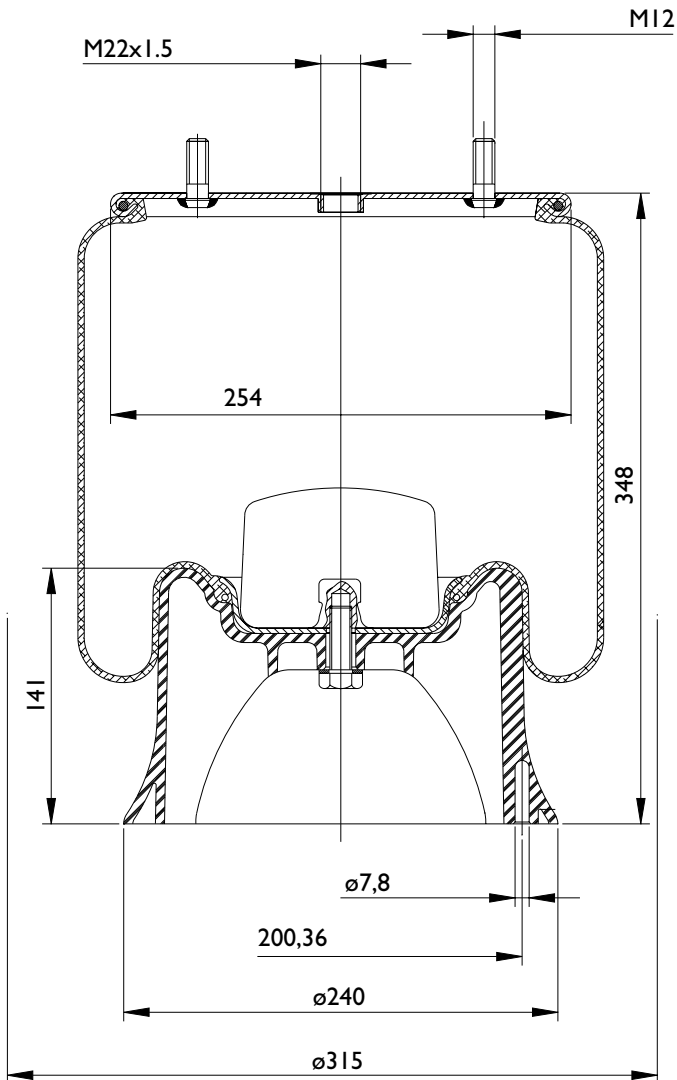

311013 Vista dall'alto

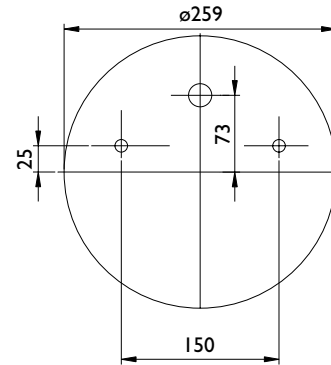

402009 Vista dal basso

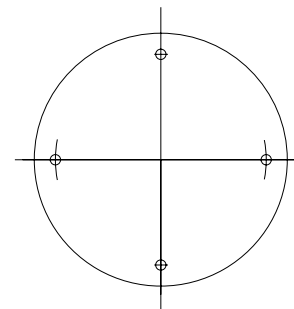

## Applicazioni principali

SAF	3.229.0029.00
SAF	4.284.3003.01

## Lista corrispondenze

CONTITECH	4022 NP 03
FIRESTONE	IT17 BS6-W01 M58 6367
PHOENIX	IDK 22E-9
TAURUS	KR725-28
DUNLOP UK	
DUNLOP F	D12 B14
GOODYEAR	I R 11-714
PIRELLI	IT300-37 / 206340
GART	



Entrata aria



Perno combinato

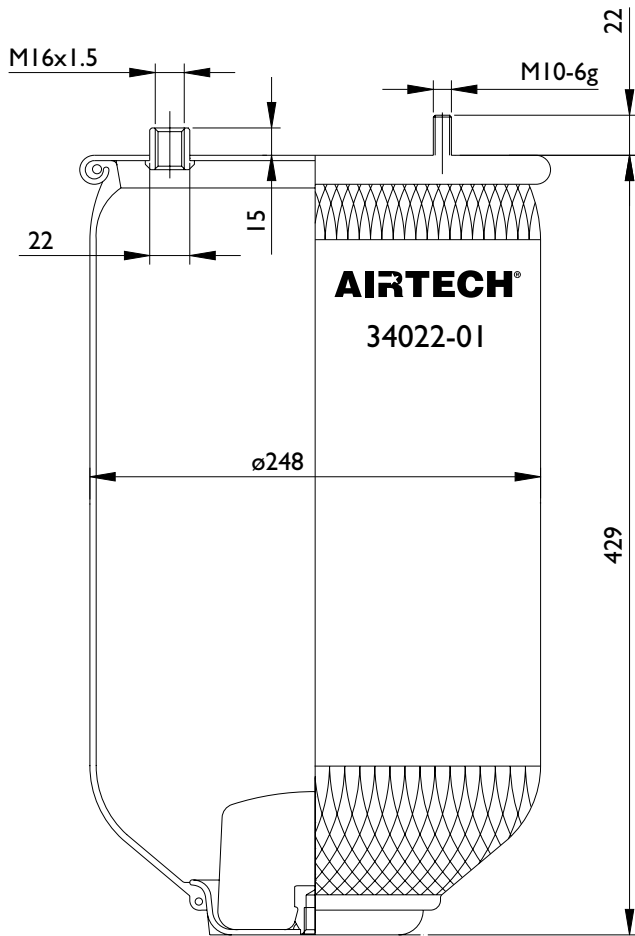

311094 Vista dall'alto

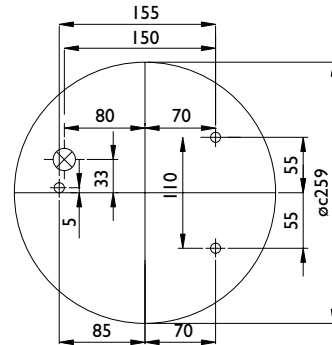

315001 Vista dal basso

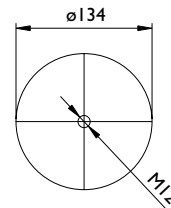

### Applicazioni principali

### Lista corrispondenze

CONTITECH	
FIRESTONE	
PHOENIX	
TAURUS	
DUNLOP UK	
DUNLOP F	
GOODYEAR	
PIRELLI	
GART	

⊗ Entrata aria

⊙ Perno combinato

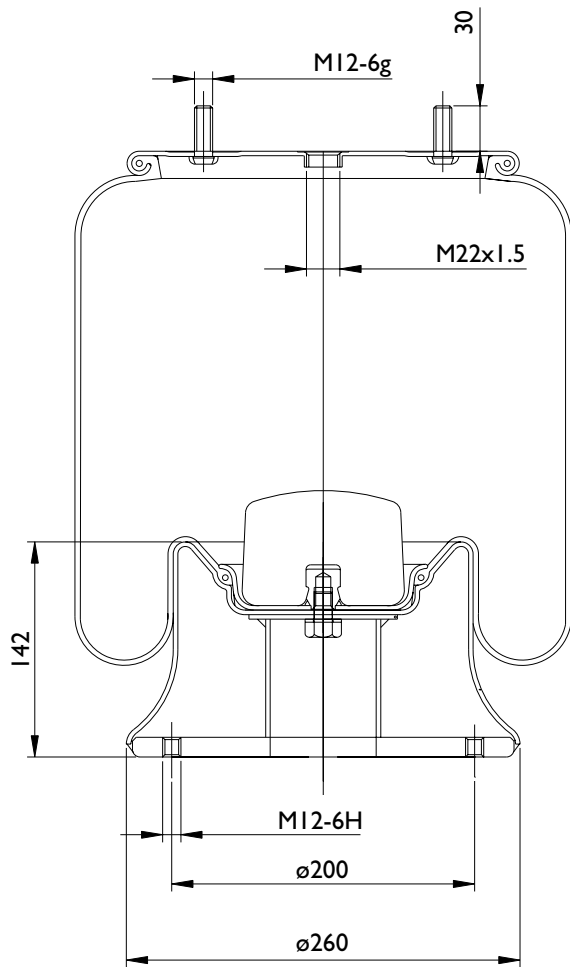

311013 Vista dall'alto

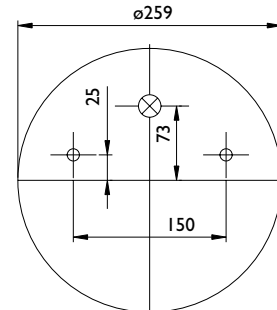

312008 Vista dal basso

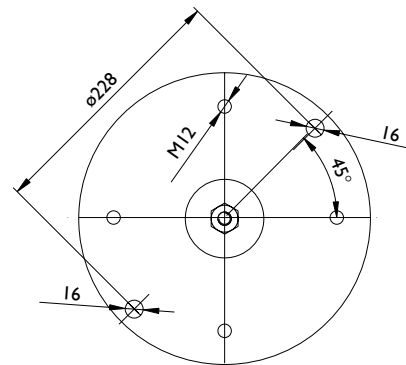

### Applicazioni principali

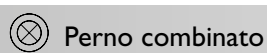
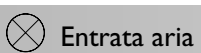

### Lista corrispondenze

CONTITECH	
FIRESTONE	
PHOENIX	
TAURUS	
DUNLOP UK	
DUNLOP F	
GOODYEAR	
PIRELLI	
GART	

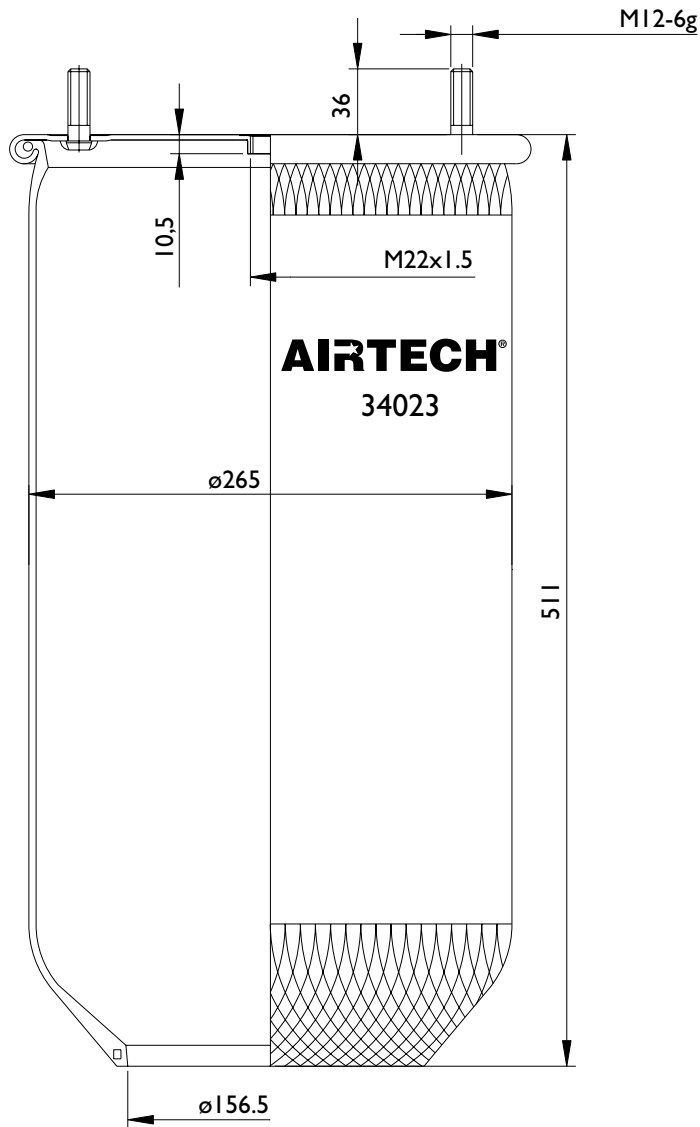
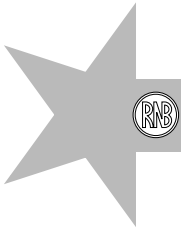

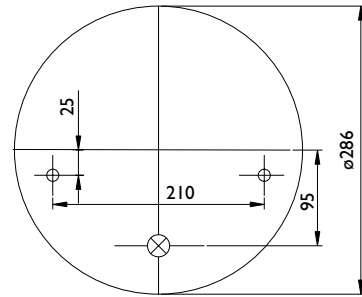

311005 Vista dall'alto



### Applicazioni principali

SAF	2923V
SAF	3.229.031.00

### Lista corrispondenze

CONTITECH	4023 N
FIRESTONE	1 T 19 L-11 / W01 M58 6335
PHOENIX	
TAURUS	
DUNLOP UK	
DUNLOP F	
GOODYEAR	
PIRELLI	1T19E2
GART	

⊗ Entrata aria

⊗ Perno combinato

# MOLLE AD ARIA COMPLETE



A520059C

**AIRTECH® 34023 K**

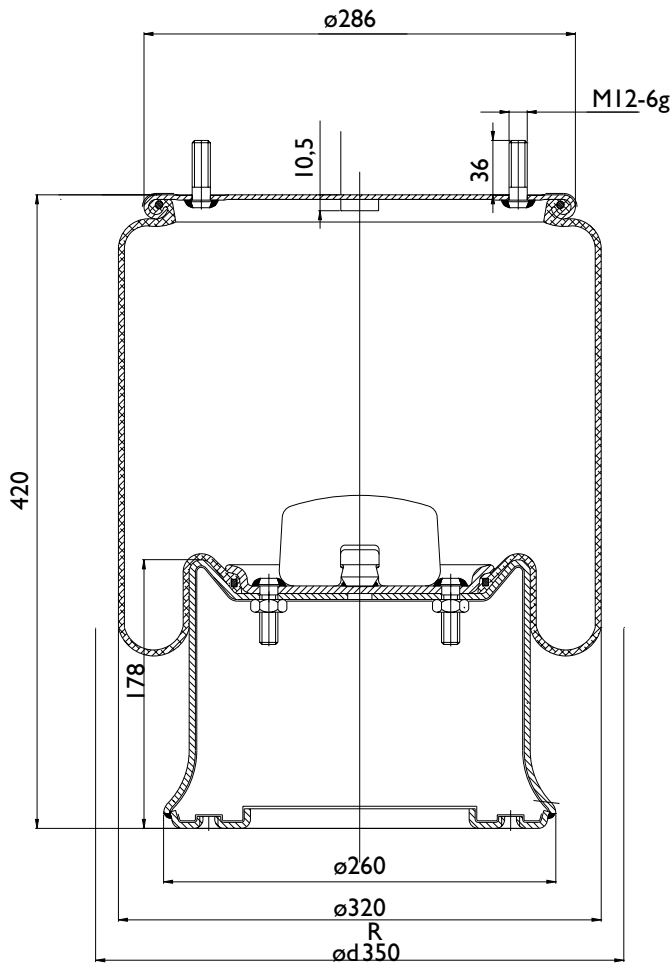

311005 Vista dall'alto

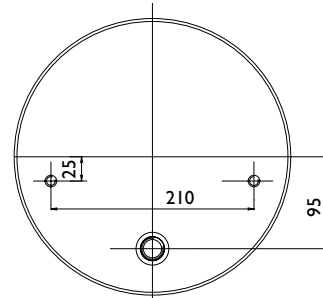

312014 Vista dal basso

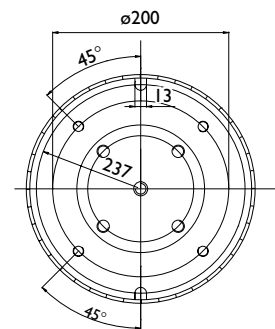

## Applicazioni principali

SAF	3.229.0031.00
SAF	2923V

## Lista corrispondenze

CONTITECH	4023 NP 03
FIRESTONE	I T 19 L-11/W01 M58 6348
PHOENIX	ID 28 B-10
TAURUS	
DUNLOP UK	
DUNLOP F	D 13 B 26
GOODYEAR	I R 14-729
PIRELLI	I T 19 E-2 / 204676
GART	D277 277.4.505



Entrata aria



Perno combinato

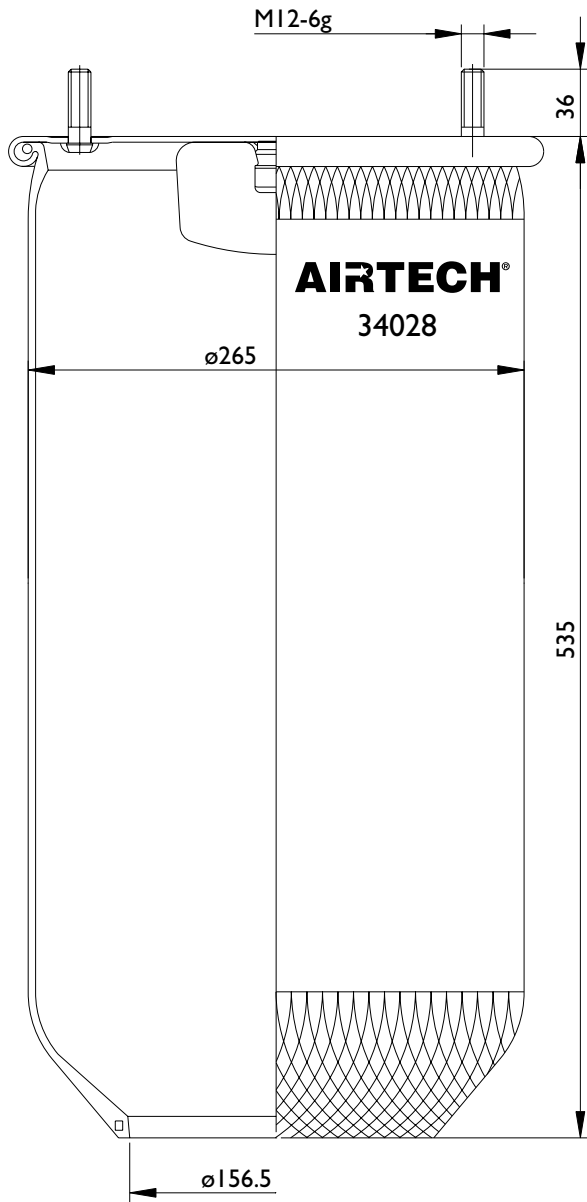

311006 Vista dall'alto

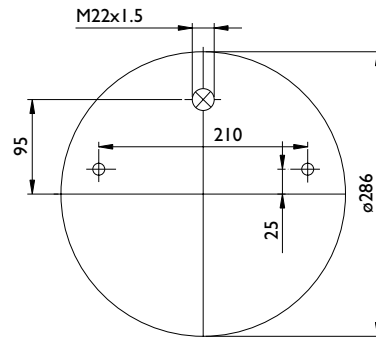

### Applicazioni principali

### Lista corrispondenze

CONTITECH	4028 N
FIRESTONE	
PHOENIX	
TAURUS	
DUNLOP UK	
DUNLOP F	
GOODYEAR	
PIRELLI	
GART	

⊗ Entrata aria

⊗ Perno combinato

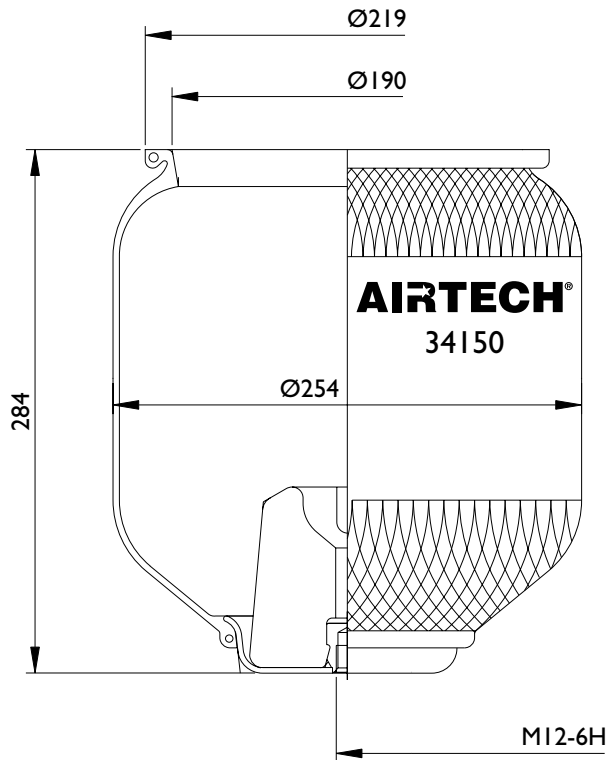

315001 Vista dal basso

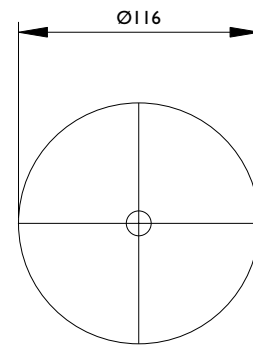

### Applicazioni principali

### Lista corrispondenze

CONTITECH	4150 NP 01
FIRESTONE	I T 15 M-0
PHOENIX	
TAURUS	
DUNLOP UK	
DUNLOP F	
GOODYEAR	I R 12 097
PIRELLI	
GART	

⊗ Entrata aria

⊗ Perno combinato



**A520057C**

**AIRTECH® 34154 KPP**

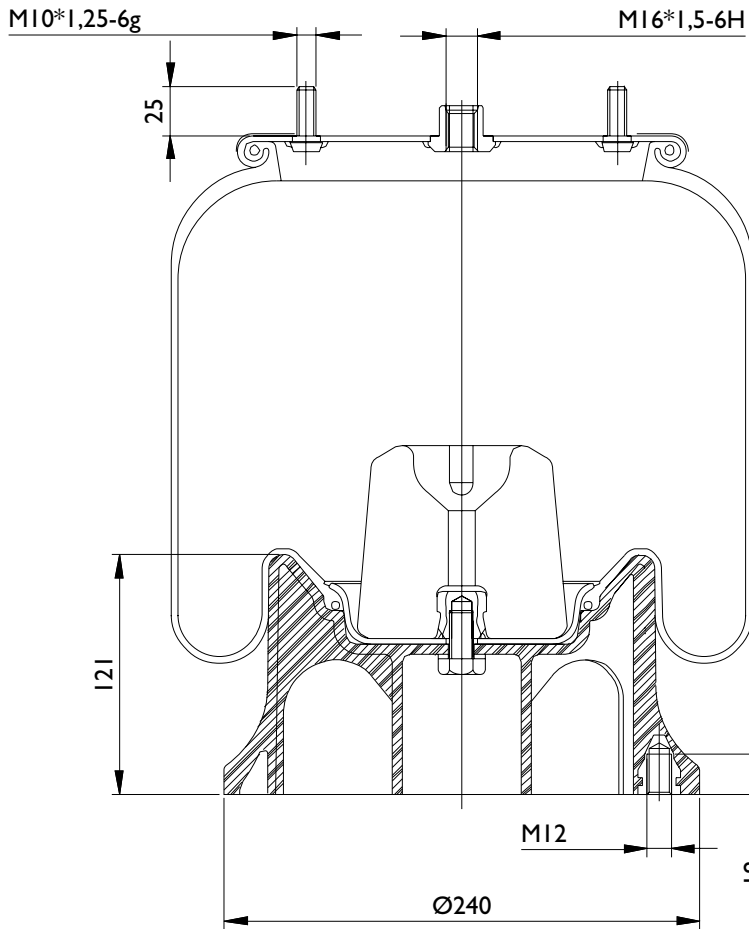

311096 Vista dall'alto

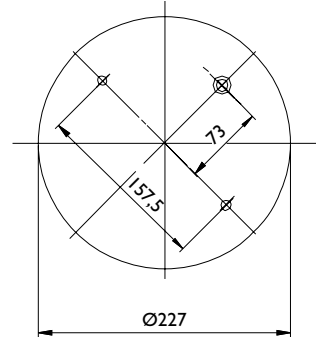

402077 Vista dal basso

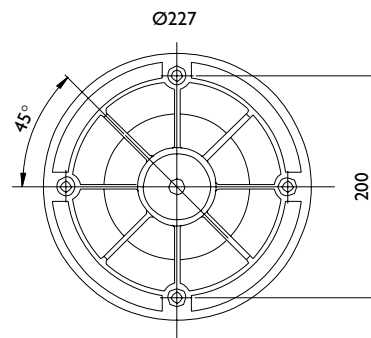

## Applicazioni principali

RENAULT R.V.I.	5010239252

## Lista corrispondenze

CONTITECH	4154 NP 05
FIRESTONE	
PHOENIX	
TAURUS	
DUNLOP UK	
DUNLOP F	
GOODYEAR	
PIRELLI	
GART	

⊗ Entrata aria

⊗ Perno combinato



# MOLLE AD ARIA COMPLETE



**AIRTECH® 34154-02 K**

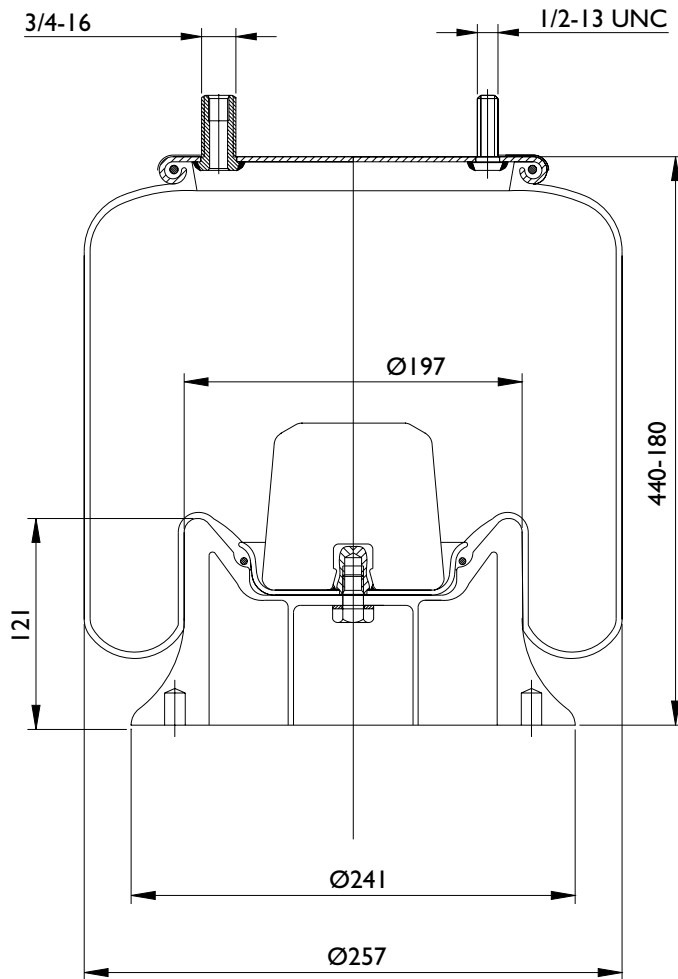

311023 Vista dall'alto

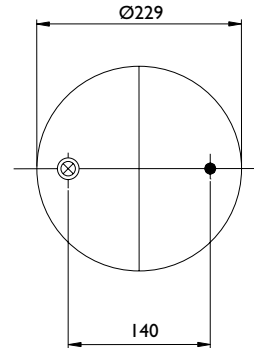

312054 Vista dal basso

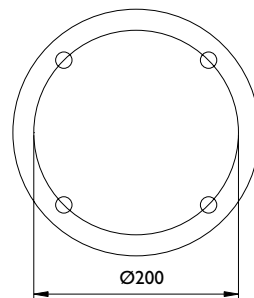

## Applicazioni principali

HENDRICKSON	B2827

## Lista corrispondenze

CONTITECH	
FIRESTONE	I T 15 M-4 / W01 358 9010
PHOENIX	
TAURUS	
DUNLOP UK	
DUNLOP F	
GOODYEAR	
PIRELLI	
GART	

⊗ Entrata aria

⊗ Perno combinato

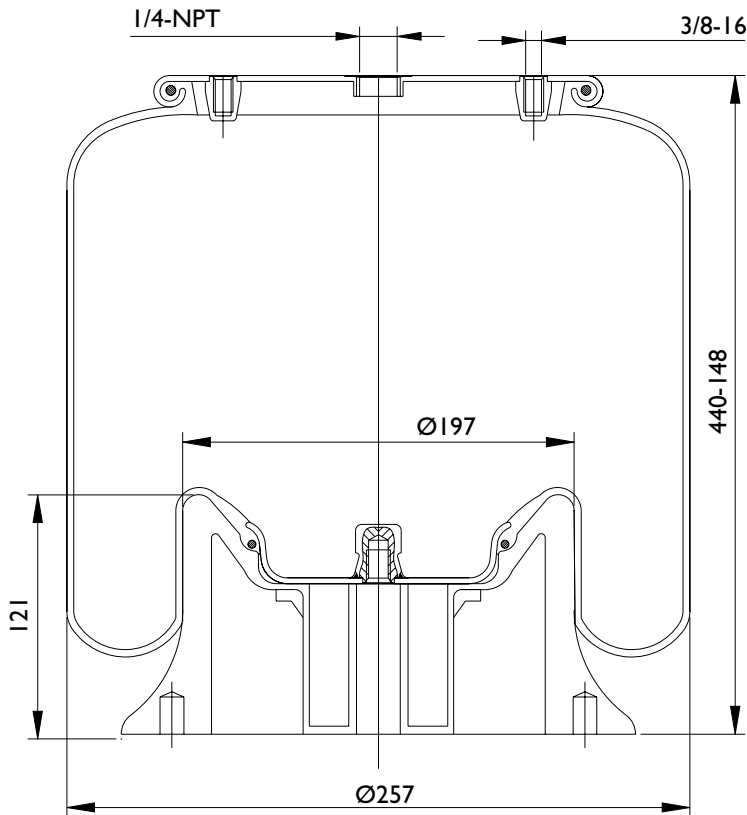

311087 Vista dall'alto

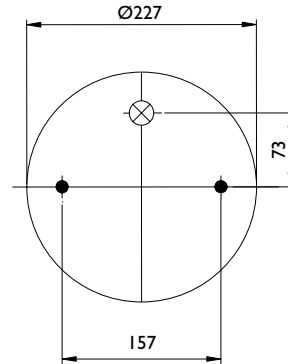

312054 Vista dal basso

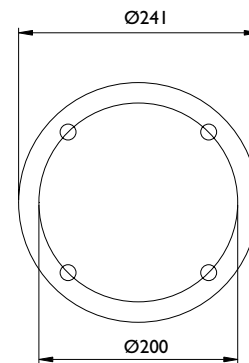

### Applicazioni principali

DAF	656991

### Lista corrispondenze

CONTITECH	
FIRESTONE	I T 15 M-4 /W01 D08 9056
PHOENIX	
TAURUS	
DUNLOP UK	
DUNLOP F	
GOODYEAR	
PIRELLI	
GART	

⊗ Entrata aria

⊗ Perno combinato

# MOLLE AD ARIA COMPLETE



**AIRTECH® 34154-04 K**

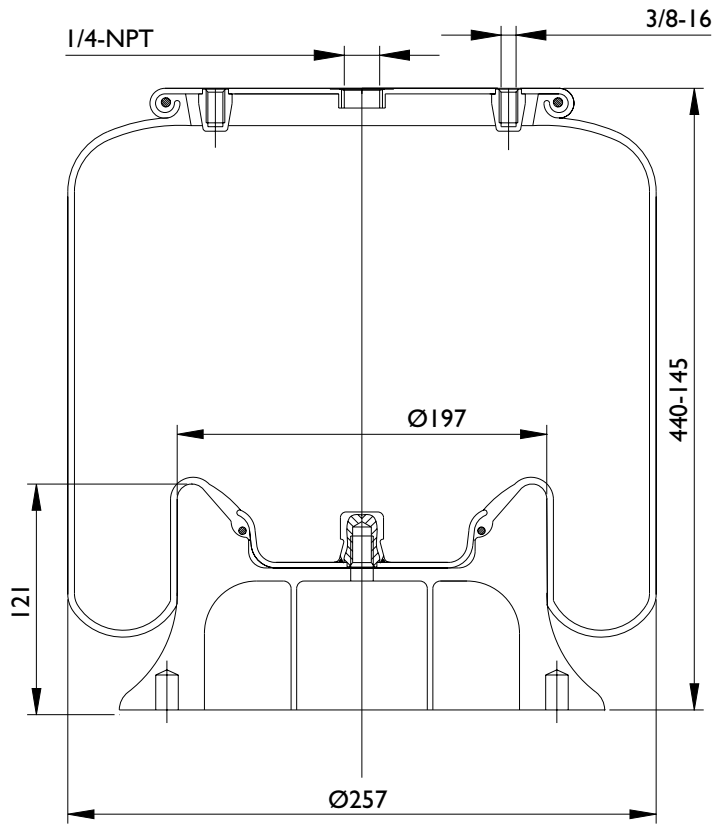

311087 Vista dall'alto

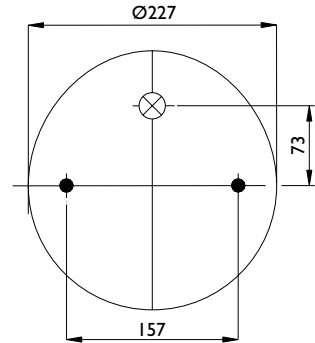

Vista dal basso

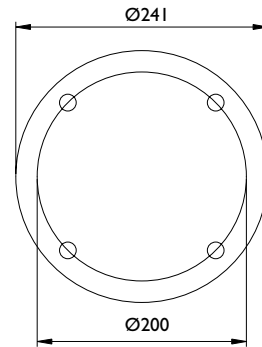

## Applicazioni principali

## Lista corrispondenze

CONTITECH	
FIRESTONE	I T 15 M-4 / W01 S05 7283
PHOENIX	
TAURUS	
DUNLOP UK	
DUNLOP F	
GOODYEAR	
PIRELLI	
GART	

Entrata aria

Perno combinato

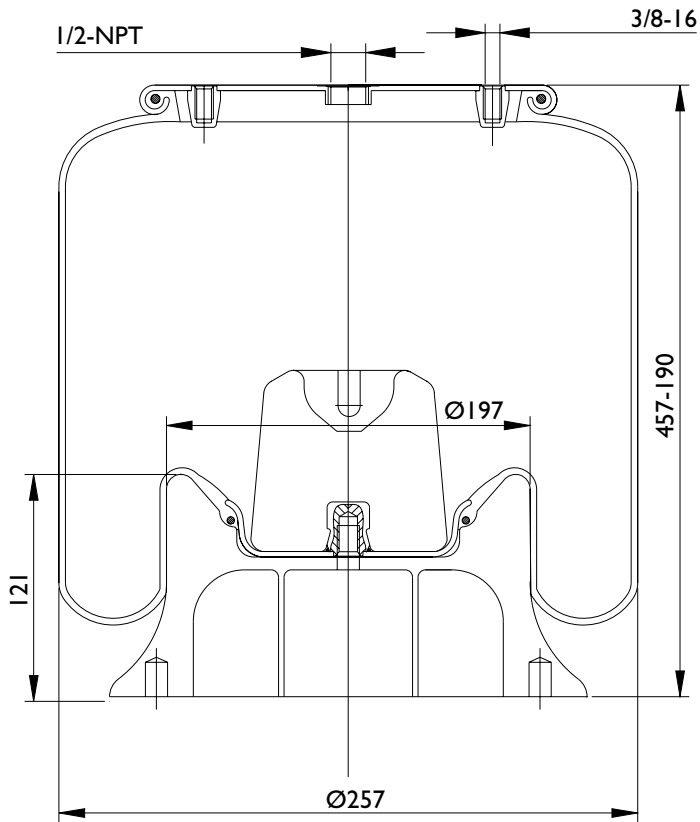

311087 Vista dall'alto

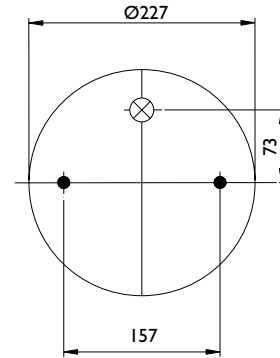

312054 Vista dal basso

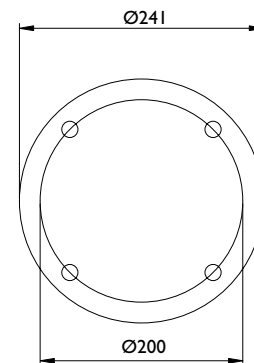

### Applicazioni principali

FODEN	I300248000

### Lista corrispondenze

CONTITECH	
FIRESTONE	I T 15 M-4 /W01 358 9069
PHOENIX	
TAURUS	
DUNLOP UK	
DUNLOP F	
GOODYEAR	I R 12-069
PIRELLI	
GART	

⊗ Entrata aria

⊗ Perno combinato

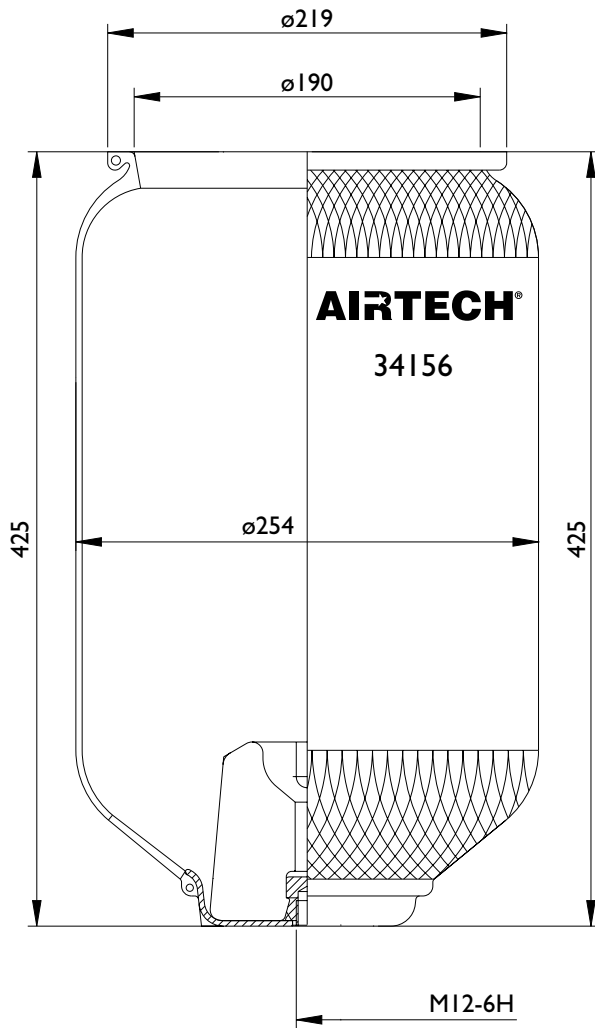

315001 Vista dal basso

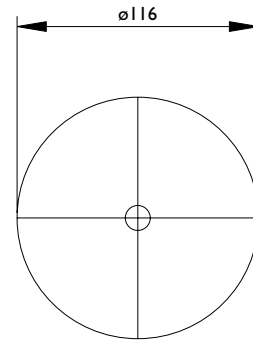

### Applicazioni principali

### Lista corrispondenze

CONTITECH	
FIRESTONE	
PHOENIX	
TAURUS	
DUNLOP UK	
DUNLOP F	
GOODYEAR	
PIRELLI	
GART	

⊗ Entrata aria

⊗ Perno combinato



**A520080**

**AIRTECH® 34156**

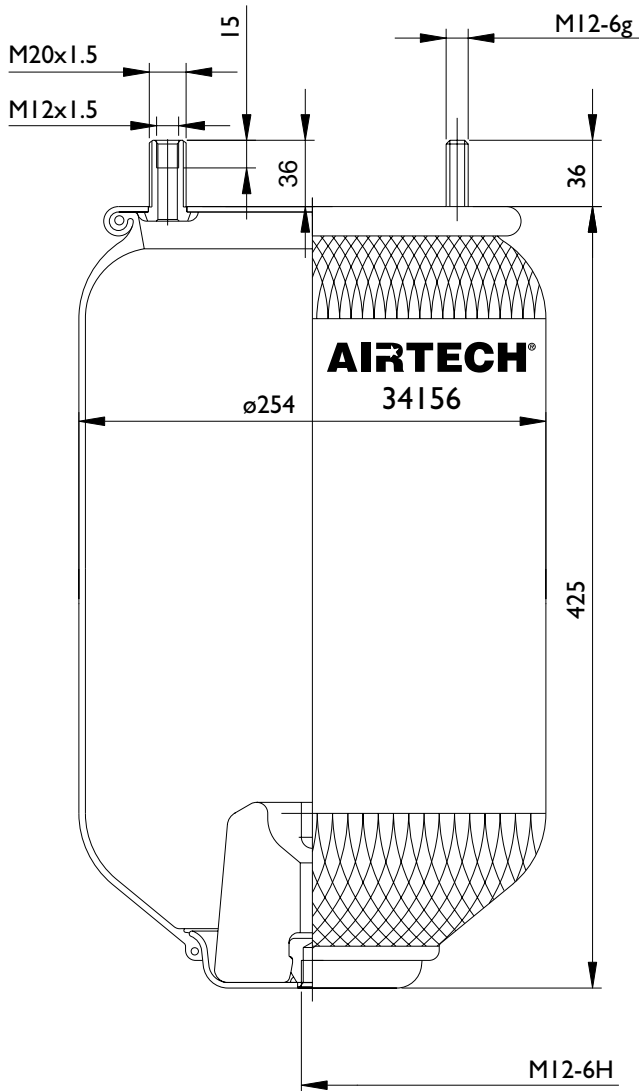

311026 Vista dall'alto

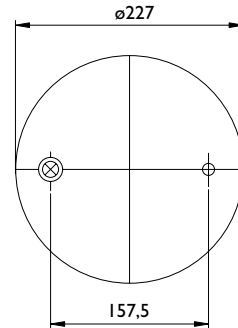

315001 Vista dal basso

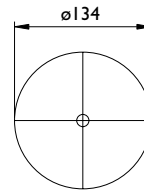

## Applicazioni principali

NEWAY	90557027
NEWAY	90557077

## Lista corrispondenze

CONTITECH	4156 NP 01
FIRESTONE	1 T 15 M-6
PHOENIX	
TAURUS	
DUNLOP UK	
DUNLOP F	
GOODYEAR	
PIRELLI	1T323-32
GART	

⊗ Entrata aria

⊗ Perno combinato

# MOLLE AD ARIA COMPLETE



A520089C

AIRTECH® 34156 KPP

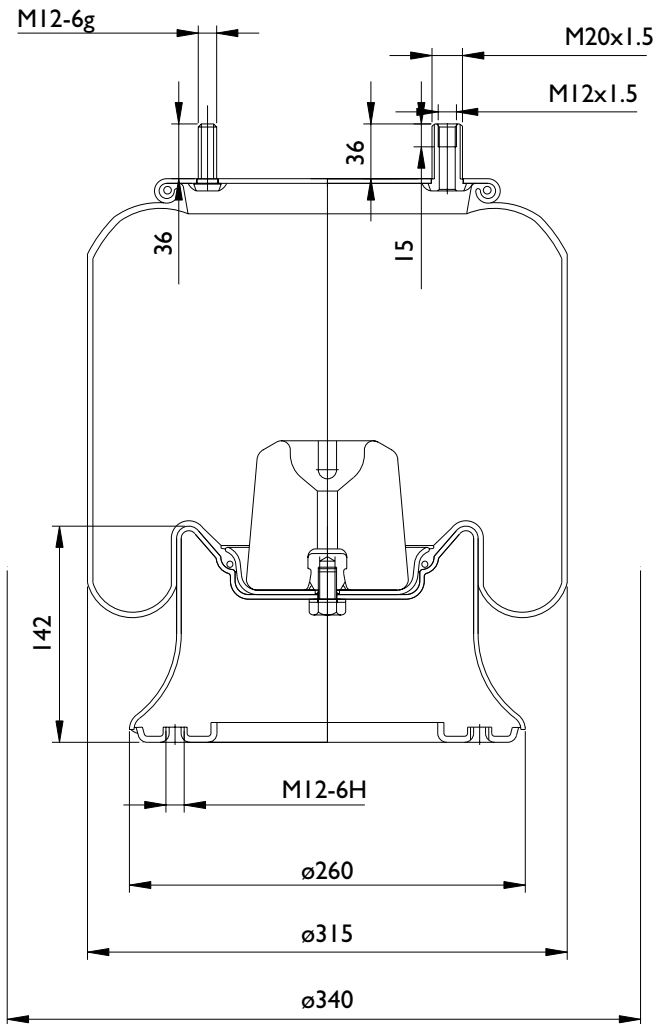

311026 Vista dall'alto

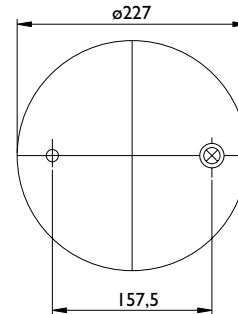

312011 Vista dal basso

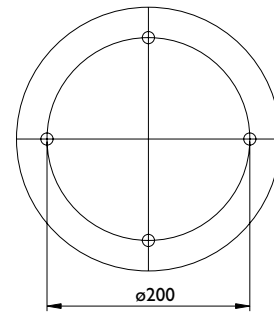

## Applicazioni principali

ROR	21215762

## Lista corrispondenze

CONTITECH	4156 NP 06
FIRESTONE	1 T 15 M-6 / W01 358 9361 (Metric)
PHOENIX	1 DK 21 A-2
TAURUS	KR 50-28
DUNLOP UK	
DUNLOP F	D12 B16
GOODYEAR	1 R 12-716
PIRELLI	1 T 323-32 / 97306
GART	D278/G 278.4.421

⊗ Entrata aria

⊗ Perno combinato

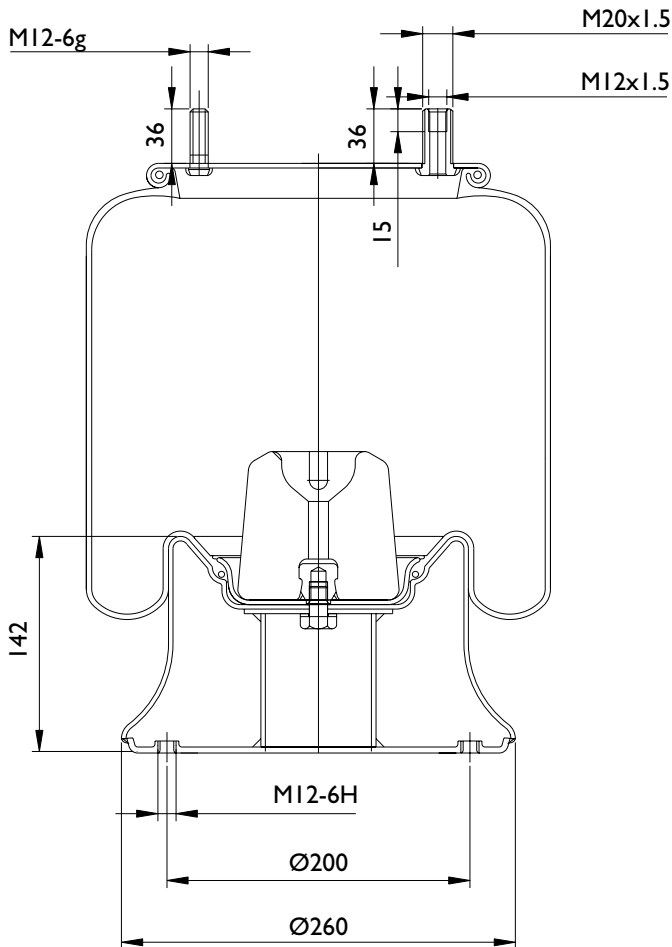

311026 Vista dall'alto

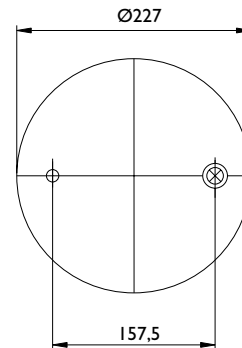

312006 Vista dal basso

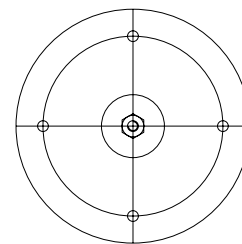

### Applicazioni principali

ROR	21215762

### Lista corrispondenze

CONTITECH	
FIRESTONE	1 T 15 M-6 / W01 358 8929 (Metric)
PHOENIX	
TAURUS	
DUNLOP UK	
DUNLOP F	
GOODYEAR	
PIRELLI	
GART	

⊗ Entrata aria

⊗ Perno combinato



# MOLLE AD ARIA SEMI-COMLETE



## AIRTECH® 34156-02

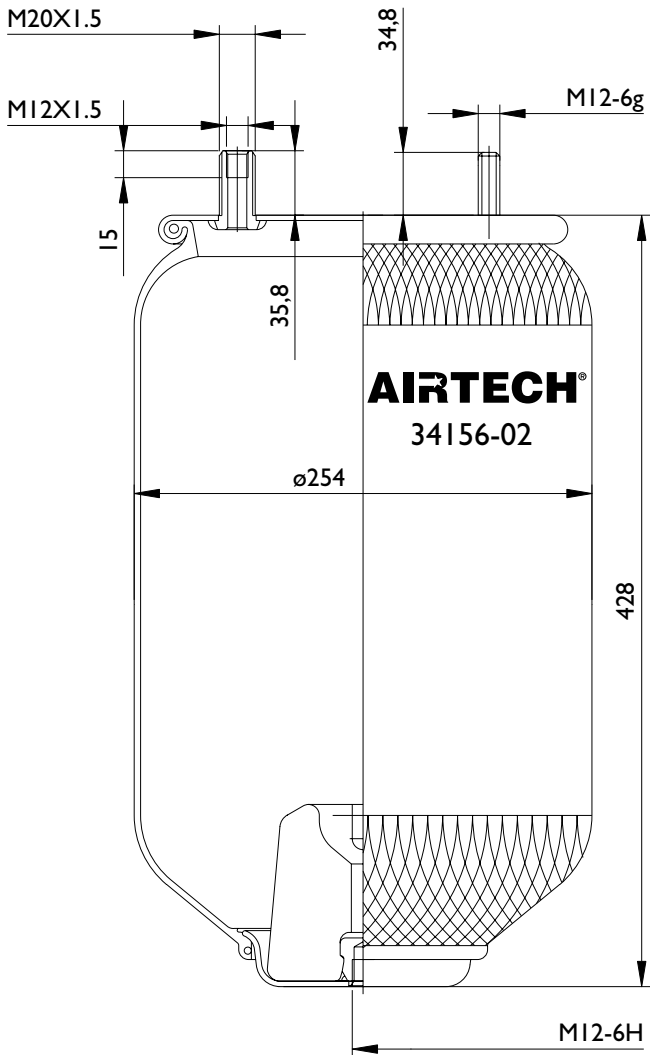

311025 Vista dall'alto

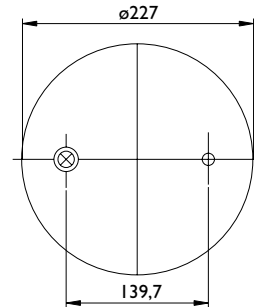

315001 Vista dal basso

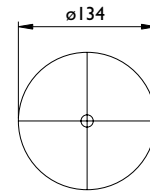

### Applicazioni principali

### Lista corrispondenze

CONTITECH	4156 NP 05
FIRESTONE	I T 15 M-6 / W01 352 0712
PHOENIX	IDK 21A-2
TAURUS	
DUNLOP UK	
DUNLOP F	
GOODYEAR	
PIRELLI	
GART	

⊗ Entrata aria

⊗ Perno combinato

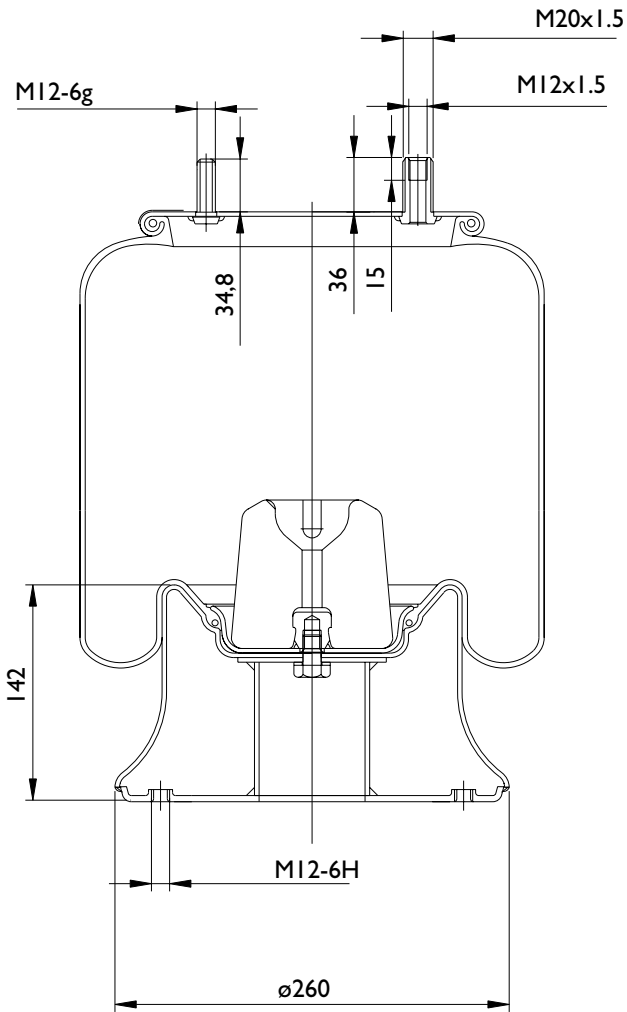
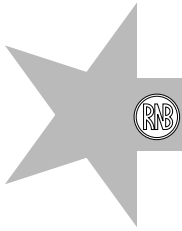

311026 Vista dall'alto

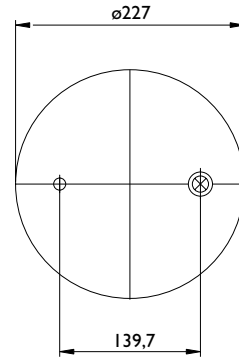

312006 Vista dal basso

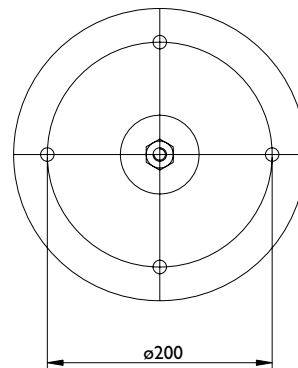

### Applicazioni principali

NEWAY	M00557002

### Lista corrispondenze

CONTITECH	
FIRESTONE	I T 15 M-6 / W01 M58 9229
PHOENIX	
TAURUS	
DUNLOP UK	
DUNLOP F	
GOODYEAR	
PIRELLI	
GART	

⊗ Entrata aria

⊗ Perno combinato

# MOLLE AD ARIA COMPLETE



A520173C

AIRTECH® 34156-03 K

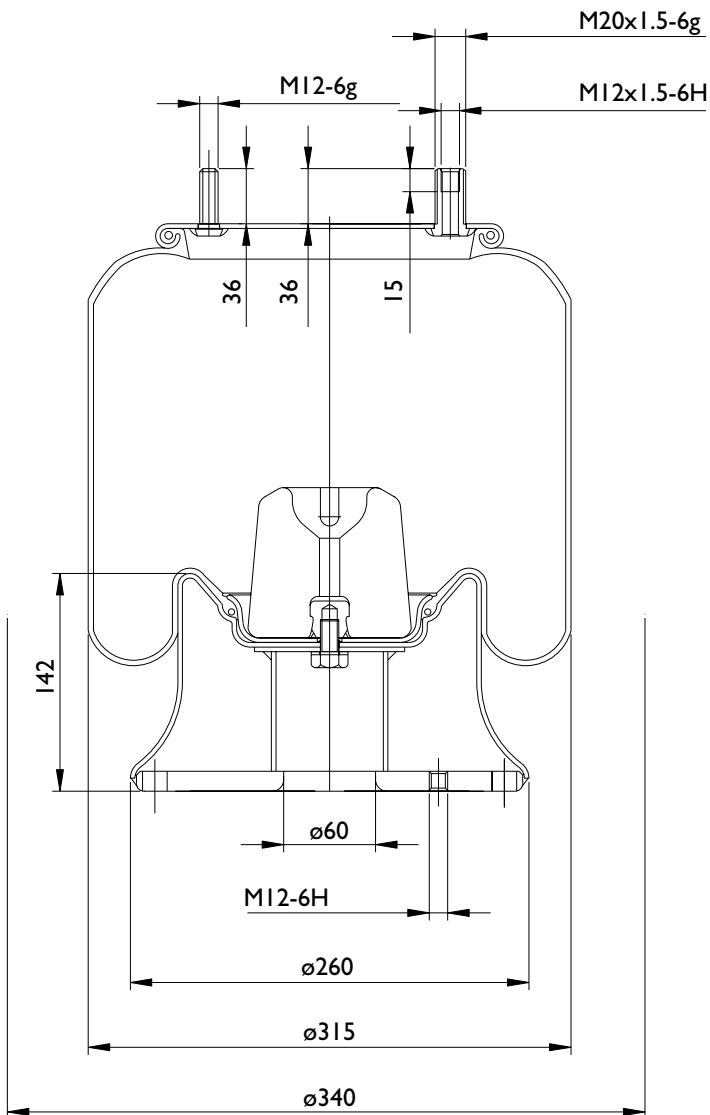

311026 Vista dall'alto

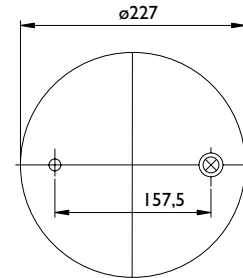

312073 Vista dal basso

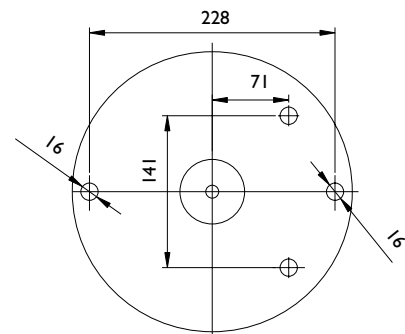

## Applicazioni principali

FRUEHAUF	M001472
FRUEHAUF	UJB0129-001

## Lista corrispondenze

CONTITECH	4156 NP 09
FIRESTONE	I T 15 M-6 / W01 379 9089
PHOENIX	
TAURUS	KR 506-28
DUNLOP UK	
DUNLOP F	D 12 B 16
GOODYEAR	I R 12-706
PIRELLI	
GART	

⊗ Entrata aria

⊗ Perno combinato

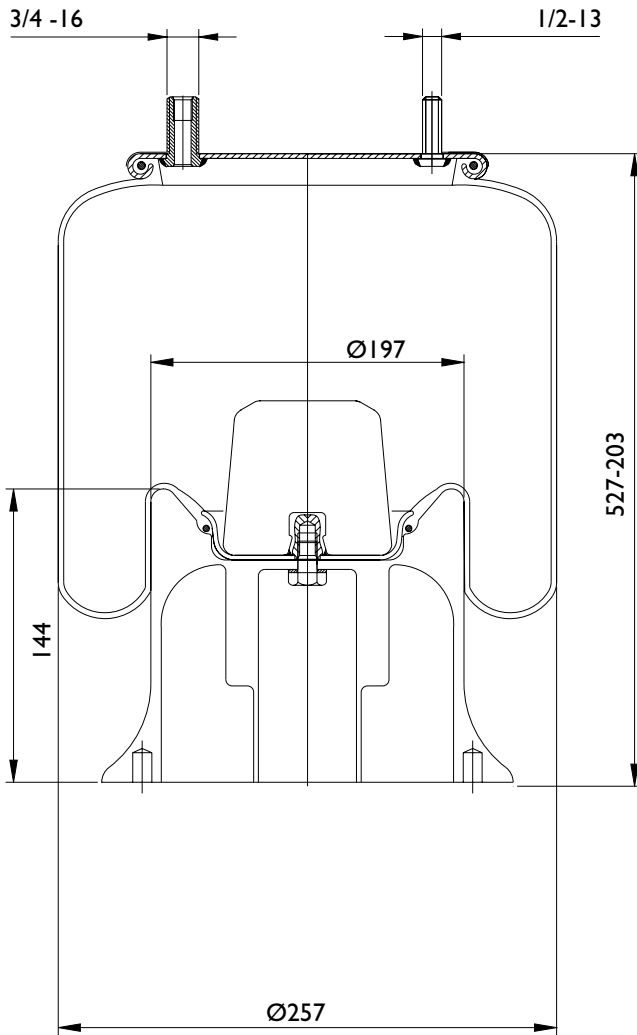

311023 Vista dall'alto

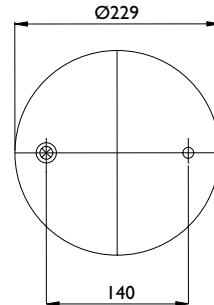

312075 Vista dal basso

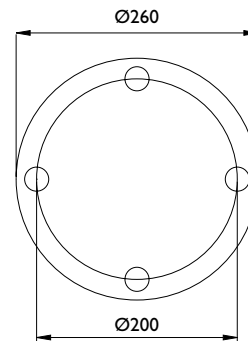

### Applicazioni principali

HENDRICKSON	B2066
NEWAY	90557006
NEWAY	90557027
NEWAY	90557031
NEWAY	90557037
NEWAY	90557075
NEWAY	AR1315-1

### Lista corrispondenze

CONTITECH	
FIRESTONE	I T 15 M-6 / W01 358 9082
PHOENIX	
TAURUS	
DUNLOP UK	
DUNLOP F	
GOODYEAR	I R 12-092
PIRELLI	
GART	

⊗ Entrata aria

⊗ Perno combinato

# MOLLE AD ARIA COMPLETE



**AIRTECH® 34156-07 K**

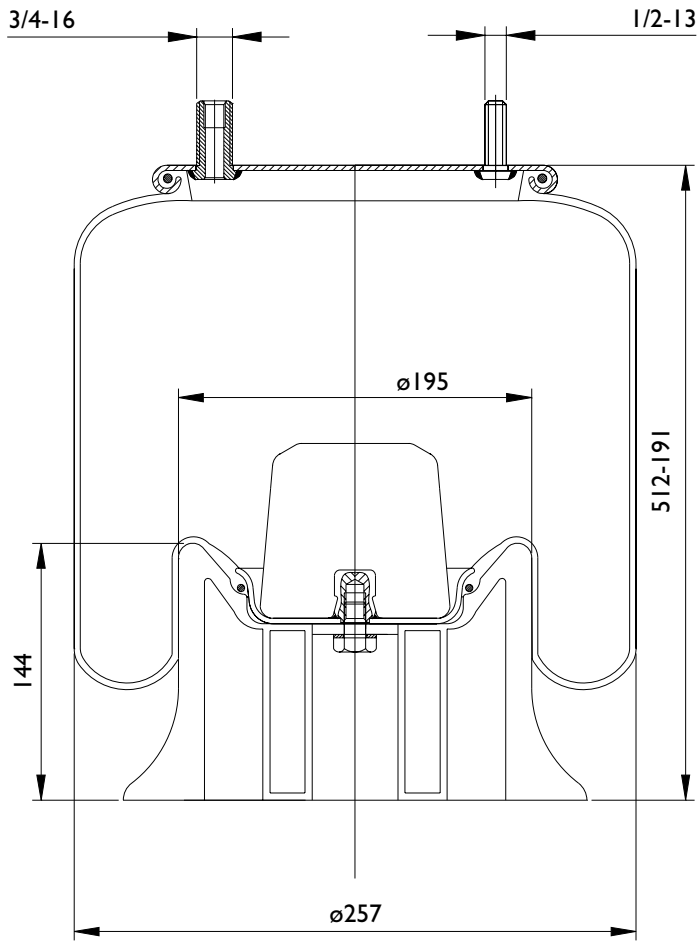

311086 Vista dall'alto

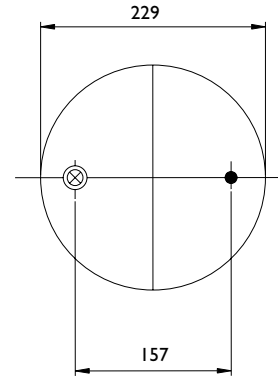

402001 Vista dal basso

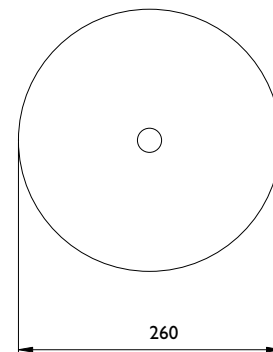

## Applicazioni principali

HENDRICKSON	HA100016

## Lista corrispondenze

CONTITECH	
FIRESTONE	I T 15 M-6 / W01 358 8929
PHOENIX	
TAURUS	
DUNLOP UK	
DUNLOP F	
GOODYEAR	I R 12-461
PIRELLI	
GART	

⊗ Entrata aria

⊗ Perno combinato

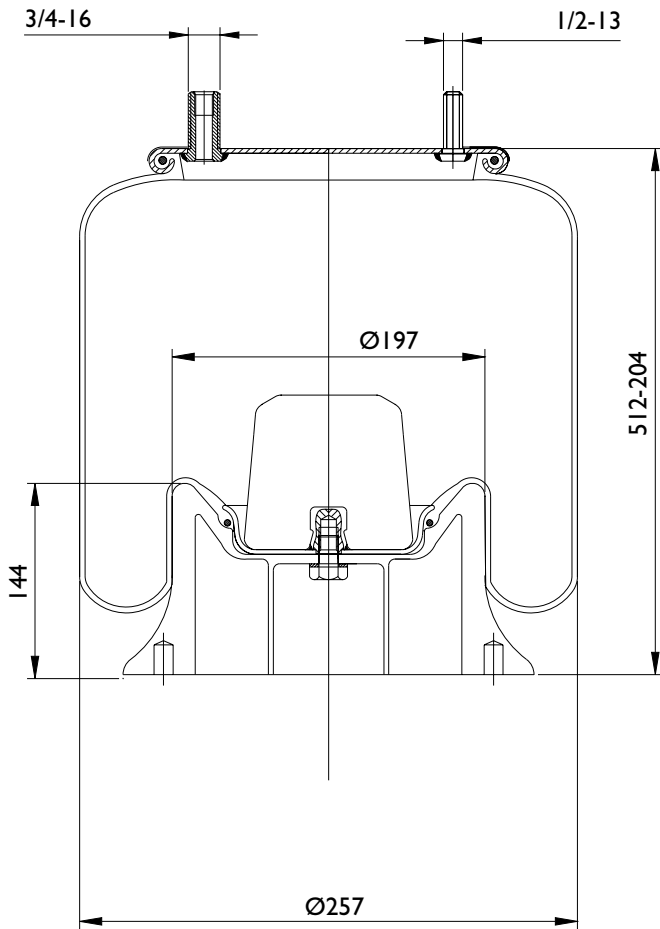
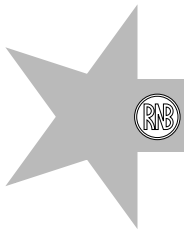

311086 Vista dall'alto

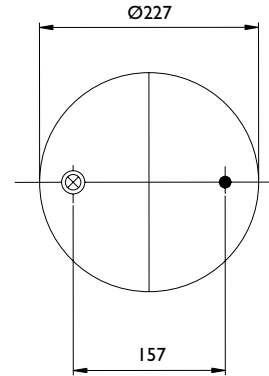

312006 Vista dal basso

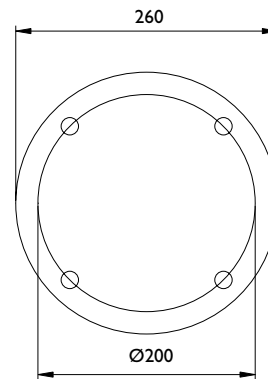

### Applicazioni principali

HENDRICKSON	HA100001
ROR/MERITOR	21215761
WEWELER	US09361F

### Lista corrispondenze

CONTITECH	
FIRESTONE	I T 15 M-6 / W01 358 9361
PHOENIX	
TAURUS	
DUNLOP UK	
DUNLOP F	
GOODYEAR	I R 12-716
PIRELLI	
GART	

⊗ Entrata aria

⊗ Perno combinato

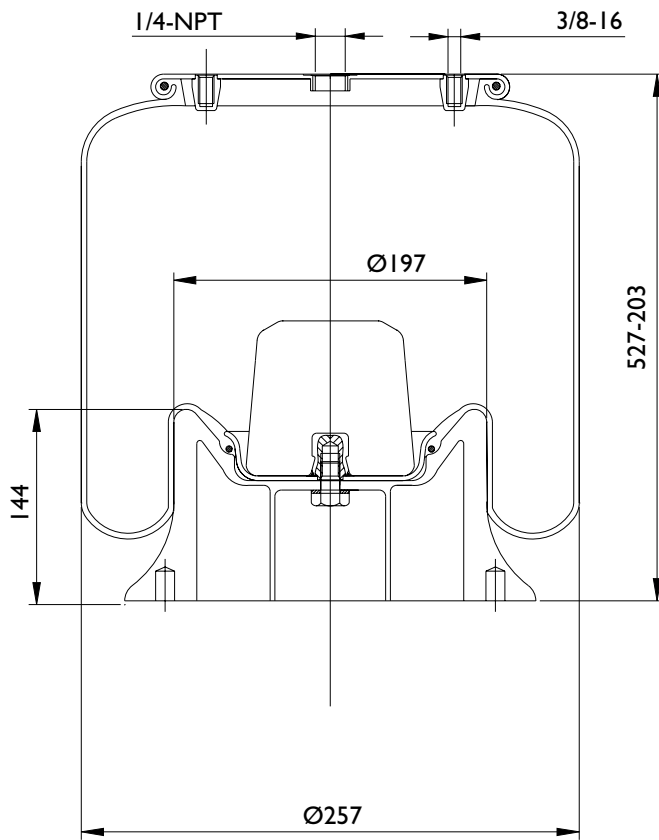

311087 Vista dall'alto

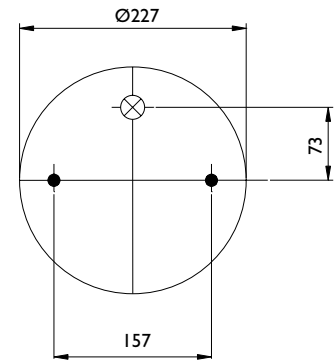

312006 Vista dal basso

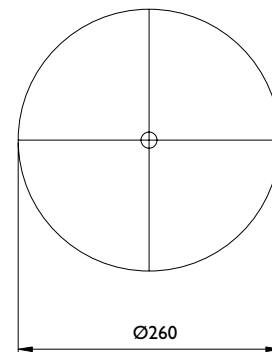

### Applicazioni principali

FRUEHAUF	UCE12304-001
TEC	507505

### Lista corrispondenze

CONTITECH	
FIRESTONE	I T 15 M-6 / W01 358 9096
PHOENIX	
TAURUS	
DUNLOP UK	
DUNLOP F	
GOODYEAR	
PIRELLI	
GART	

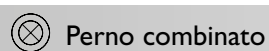

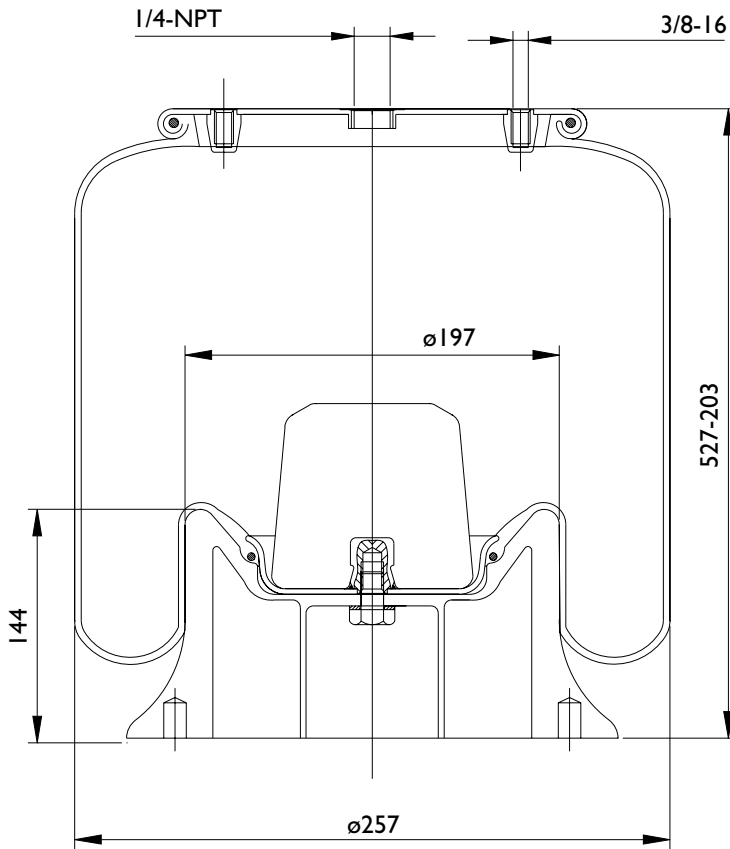

311026 Vista dall'alto

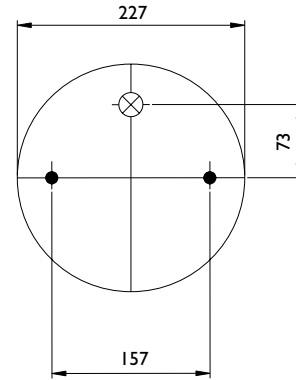

Vista dal basso

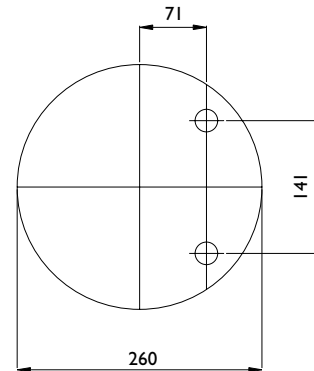

### Applicazioni principali

### Lista corrispondenze

CONTITECH	
FIRESTONE	I T 15 M-6 / W01 379-9207
PHOENIX	
TAURUS	
DUNLOP UK	
DUNLOP F	
GOODYEAR	
PIRELLI	
GART	

⊗ Entrata aria

⊗ Perno combinato



# MOLLE AD ARIA COMPLETE



## AIRTECH® 34156-11 K

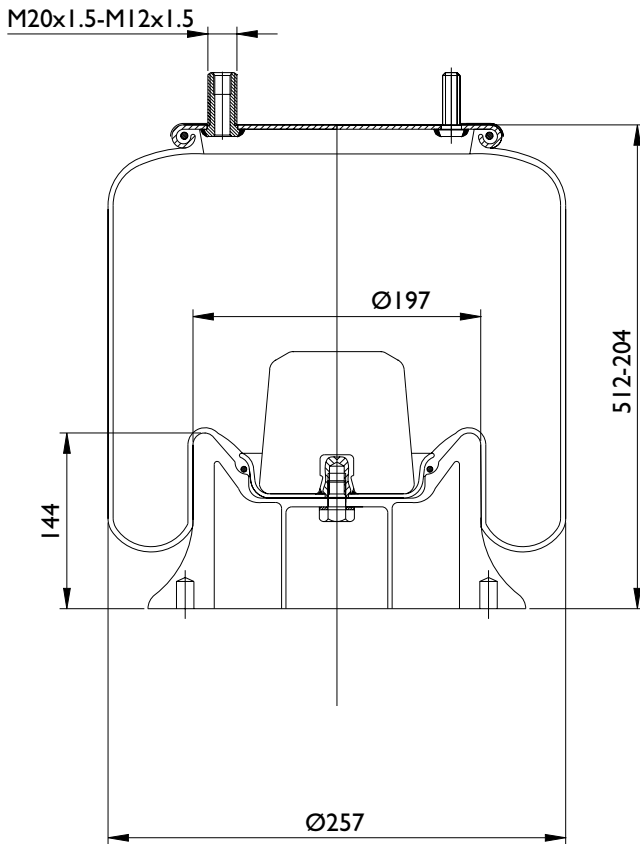

311025 Vista dall'alto

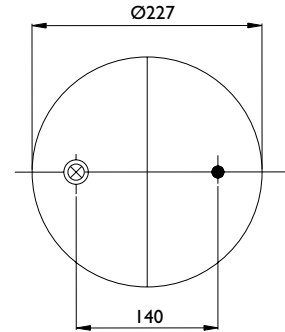

312006 Vista dal basso

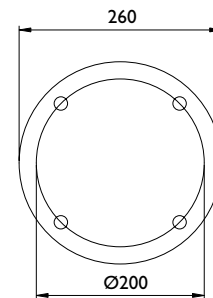

### Applicazioni principali

FODEN	I300522000

### Lista corrispondenze

CONTITECH	
FIRESTONE	I T 15 M-6 / W01 F 79-7349
PHOENIX	
TAURUS	
DUNLOP UK	
DUNLOP F	
GOODYEAR	
PIRELLI	
GART	

⊗ Entrata aria

⊗ Perno combinato



**A520133C**

**AIRTECH® 34157 KP**

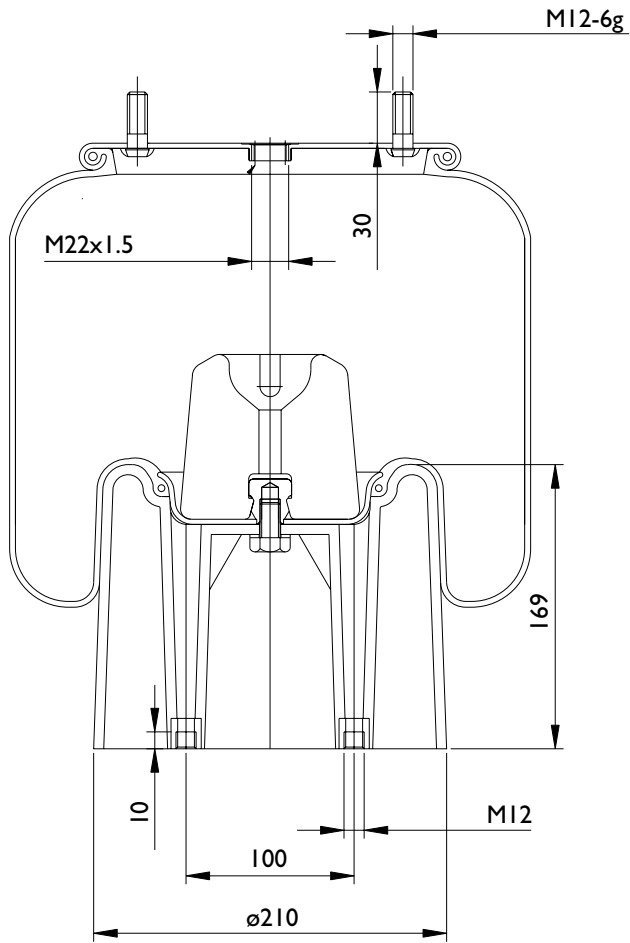

311028 Vista dall'alto

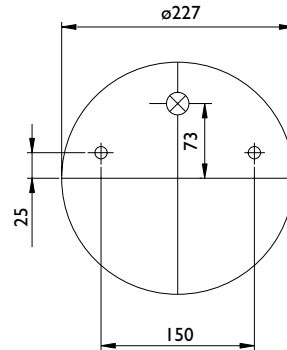

402001 Vista dal basso

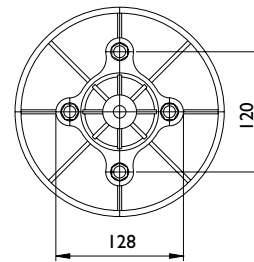

## Applicazioni principali

ROR/MERITOR	21221307

## Lista corrispondenze

CONTITECH	4157 NP 04
FIRESTONE	1 T 15 MPW-7 / W01 M58 6297
PHOENIX	IDK 20-A1
TAURUS	KR915-52
DUNLOP UK	
DUNLOP F	
GOODYEAR	
PIRELLI	
GART	

⊗ Entrata aria

⊗ Perno combinato

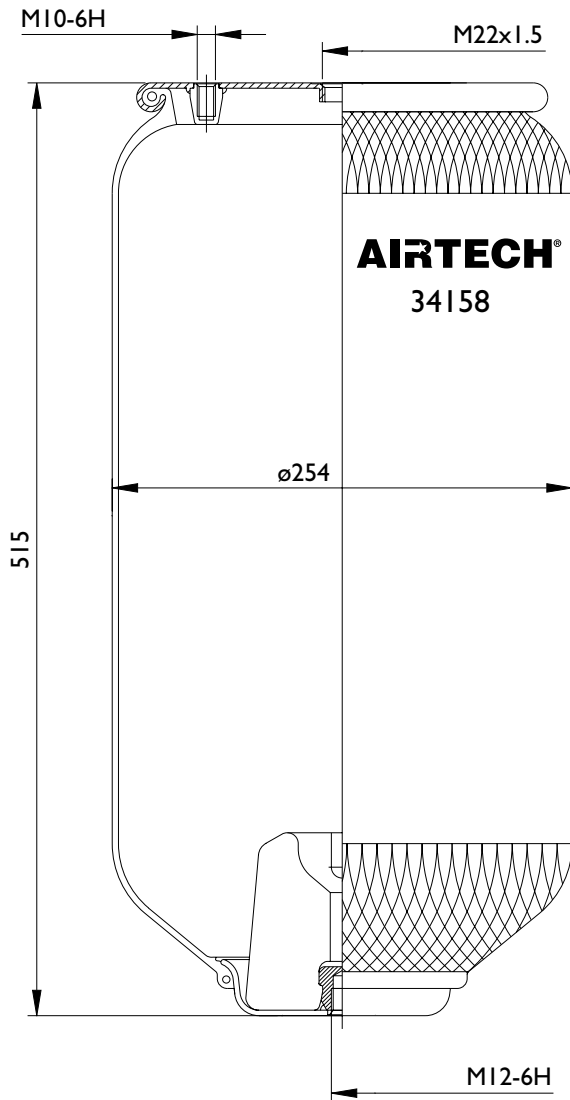

311112 Vista dall'alto

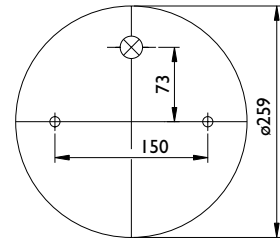

315001 Vista dal basso

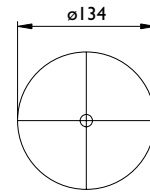

### Applicazioni principali

SCHMITZ	751065

### Lista corrispondenze

CONTITECH	4158 NP 02
FIRESTONE	IT15 MPW7
PHOENIX	
TAURUS	
DUNLOP UK	
DUNLOP F	
GOODYEAR	
PIRELLI	
GART	

⊗ Entrata aria

⊗ Perno combinato



A520091C

AIRTECH® 34158 KPP

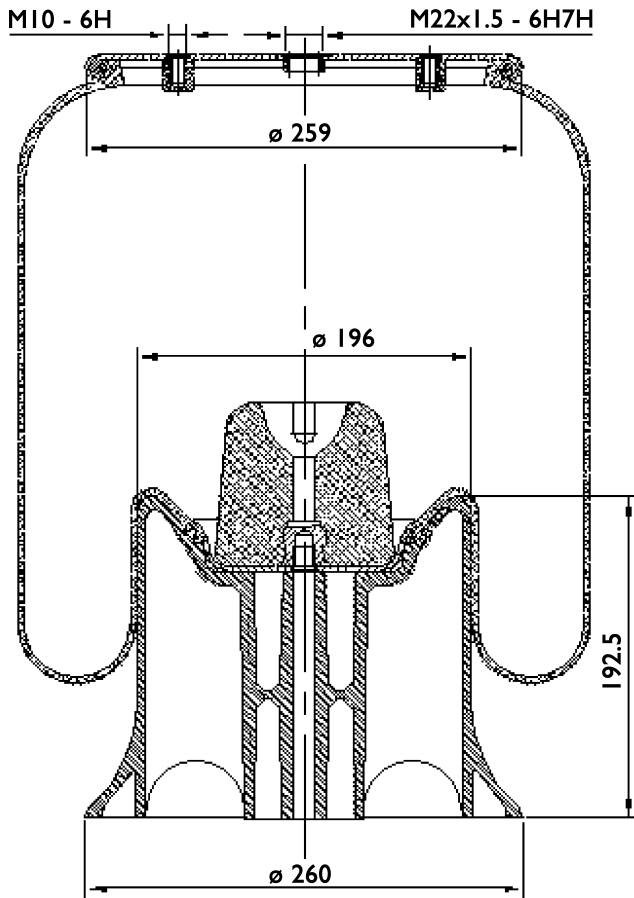

311072 Vista dall'alto

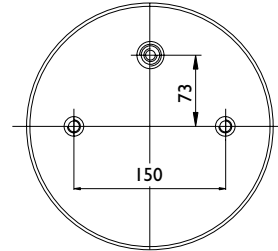

402014 Vista dal basso

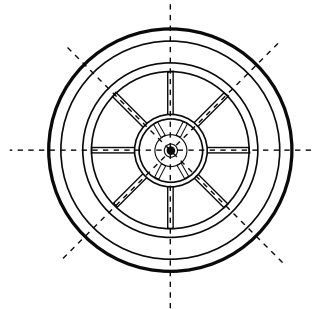

## Applicazioni principali

SCHMITZ	750999
WEWELER	US 06285F

## Lista corrispondenze

CONTITECH	4158 NP03
FIRESTONE	1 T 15 MPW9 / W01 M58 8185
PHOENIX	IDK 20-B1
TAURUS	
DUNLOP UK	
DUNLOP F	
GOODYEAR	1 R 12-749
PIRELLI	
GART	D278HS 278.1.530

⊗ Entrata aria

⊗ Perno combinato

# MOLLE AD ARIA SEMI-COMLETE



A520117

**AIRTECH® 34159**

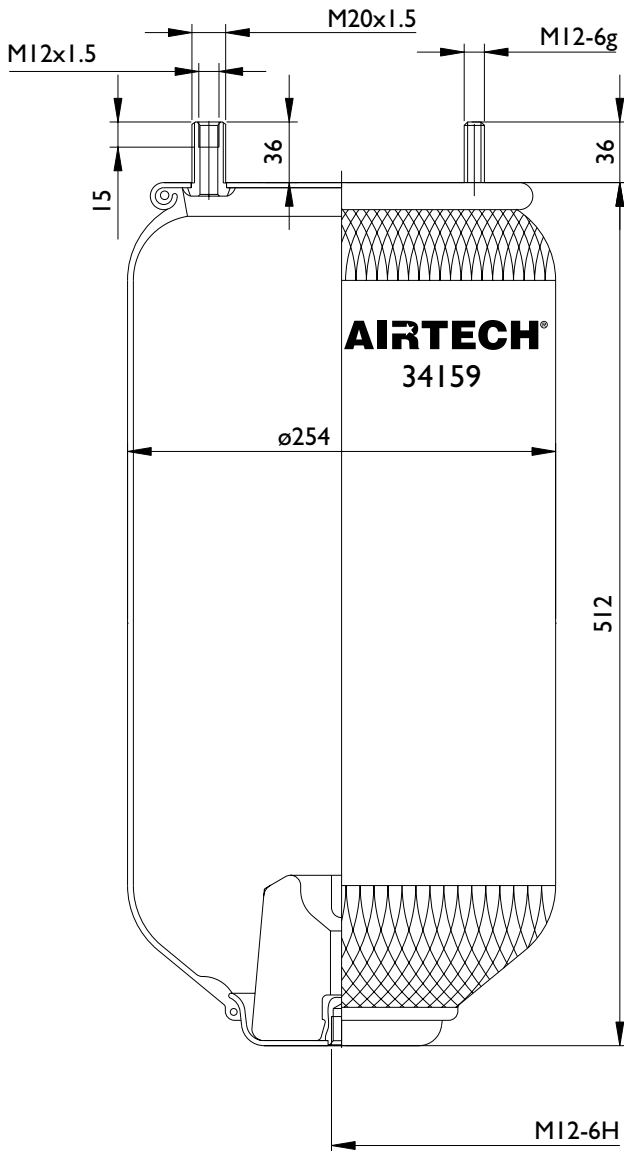

311026 Vista dall'alto

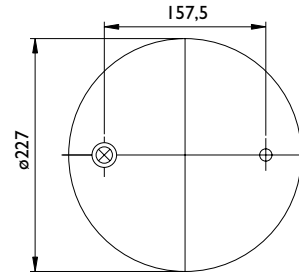

315001 Vista dal basso

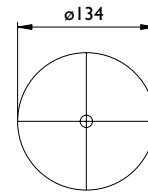

## Applicazioni principali

## Lista corrispondenze

CONTITECH	4159 NP 05
FIRESTONE	I T 15 M-9
PHOENIX	
TAURUS	
DUNLOP UK	
DUNLOP F	
GOODYEAR	I R 12-761
PIRELLI	I T 323-40
GART	

⊗ Entrata aria

⊗ Perno combinato

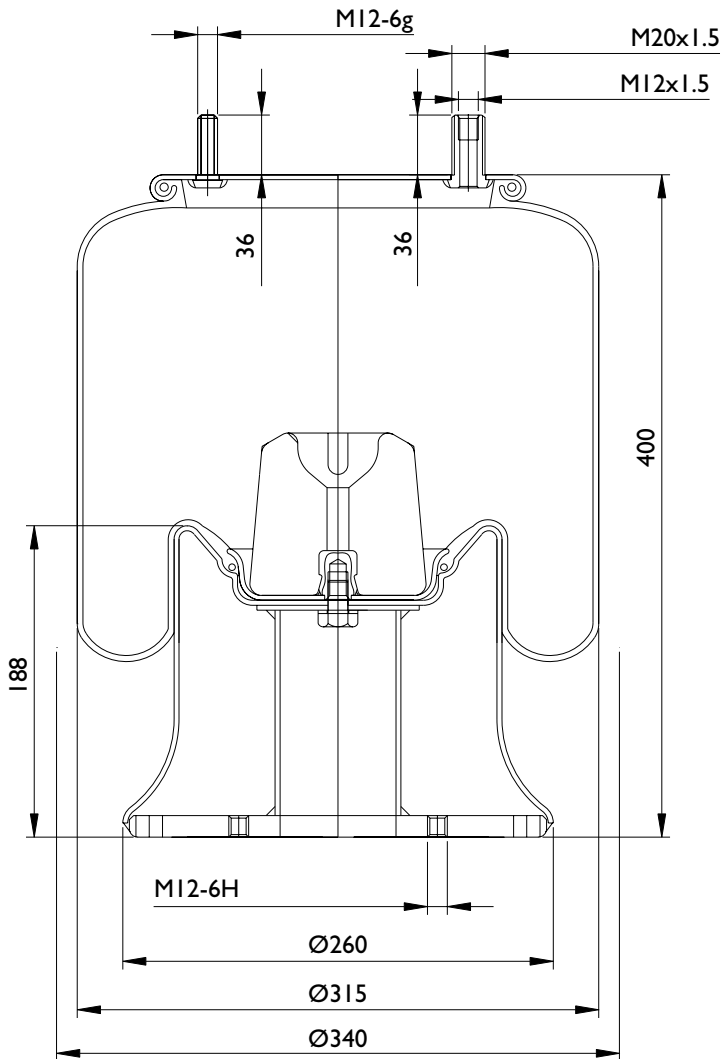
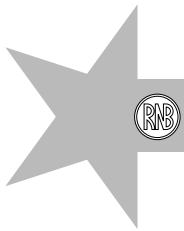

311026 Vista dall'alto

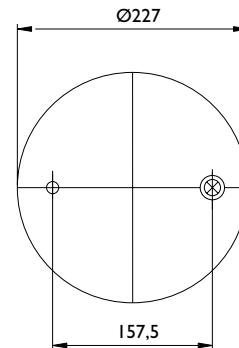

312015 Vista dal basso

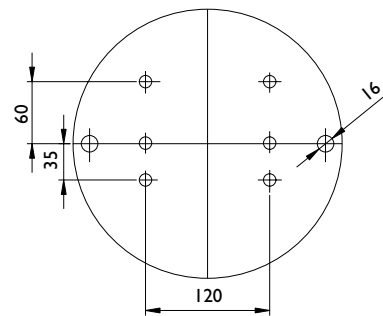

### Applicazioni principali

### Lista corrispondenze

CONTITECH	4159NP05
FIRESTONE	IT 15 M-9
PHOENIX	IDK21B5-B2
TAURUS	K509-22
DUNLOP UK	
DUNLOP F	D12B08
GOODYEAR	IR12-70I
PIRELLI	IT323-40
GART	D278/H

⊗ Entrata aria

⊗ Perno combinato

# MOLLE AD ARIA COMPLETE



A520066C

AIRTECH® 34159-02 K

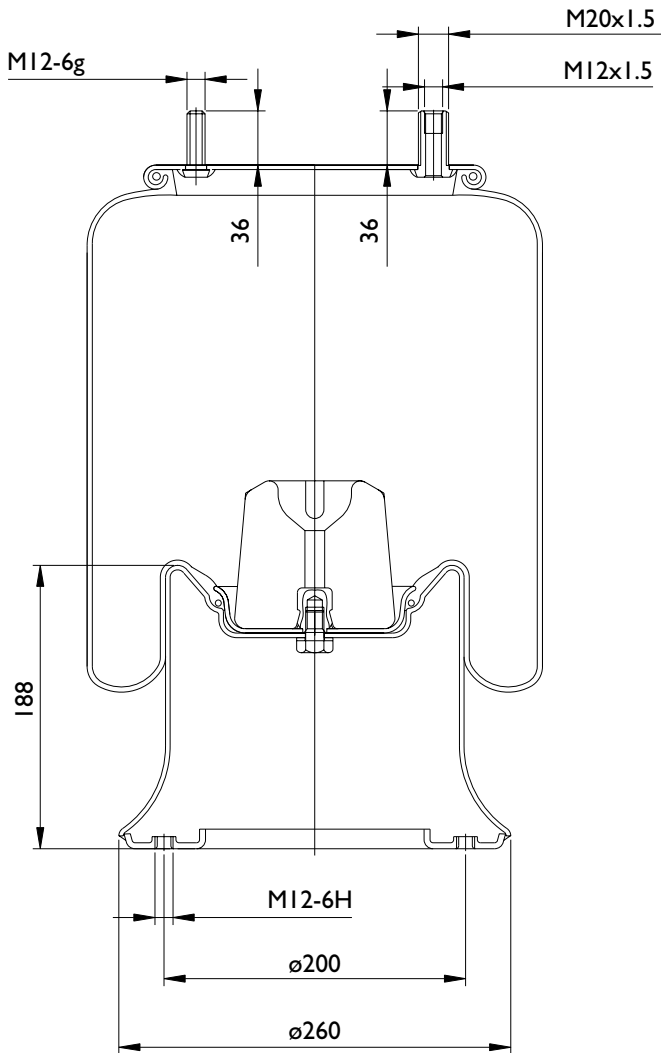

311026 Vista dall'alto

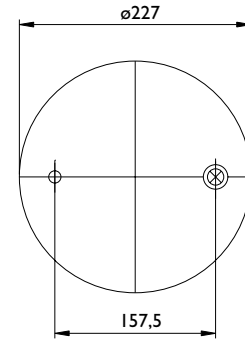

312010 Vista dal basso

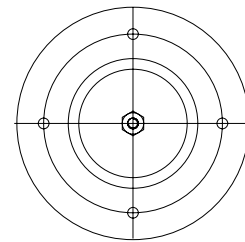

## Applicazioni principali

FREUHAUF	UJB0203001
NEWAY	90557075
ROR/MERITOR	21215891
ROR/MERITOR	21216135
SMB	M001782
WEWELER	I535864F

## Lista corrispondenze

CONTITECH	4159 NP 06
FIRESTONE	I T 15 M-9 / W01 M58 9130
PHOENIX	I DK 21 B2
TAURUS	KR 509-25
DUNLOP UK	PNP 31 I370000
DUNLOP F	D 12 B 02
GOODYEAR	I R 12-701
PIRELLI	I T 323-40 / 204124
GART	D278/H 278.4.511

⊗ Entrata aria

⊗ Perno combinato



**A520094C**

**AIRTECH® 34159-02 KPP**

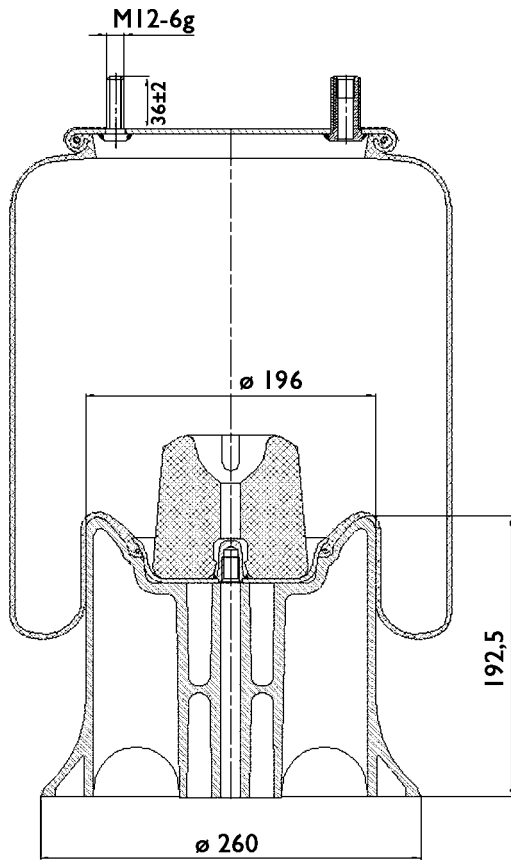

311002 Vista dall'alto

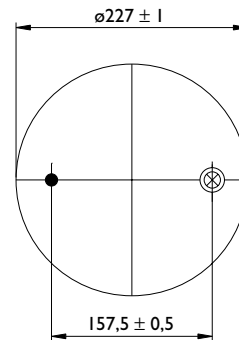

402014 Vista dal basso

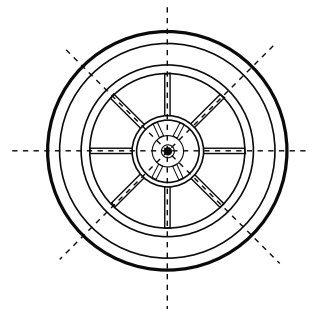

## Applicazioni principali

CARDI	58051210
FRUEHAUF	1525199
SEG-SAMRO	H2500324
SMB	M001774
TROUILLET	HT 18002
VIBERTI	128147123

## Lista corrispondenze

CONTITECH	
FIRESTONE	IT 15 M-9 / W01 379-9131
PHOENIX	IDK21B8
TAURUS	KR 509-25
DUNLOP UK	PNP 311 370 000
DUNLOP F	D 12 B 02
GOODYEAR	I R 12-721
PIRELLI	IT323-40 / 200751
GART	D278/H 278.1.510

⊗ Entrata aria

⊗ Perno combinato



# MOLLE AD ARIA SEMI-COMPLETE



**AIRTECH® 34159-03**

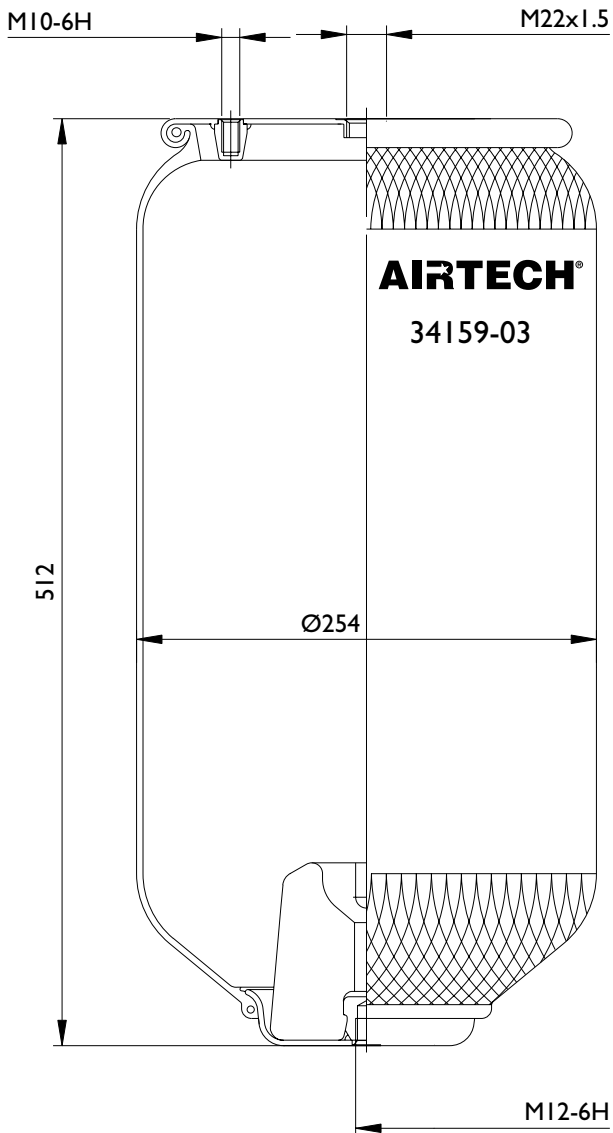

311112 Vista dall'alto

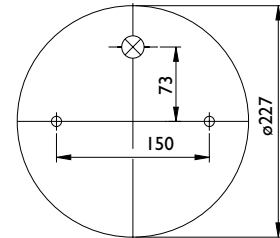

315001 Vista dal basso

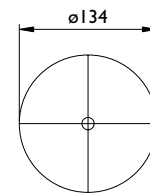

## Applicazioni principali

## Lista corrispondenze

CONTITECH	
FIRESTONE	
PHOENIX	
TAURUS	
DUNLOP UK	PNP 311370000
DUNLOP F	D 12 B 08
GOODYEAR	
PIRELLI	
GART	

⊗ Entrata aria

⊗ Perno combinato

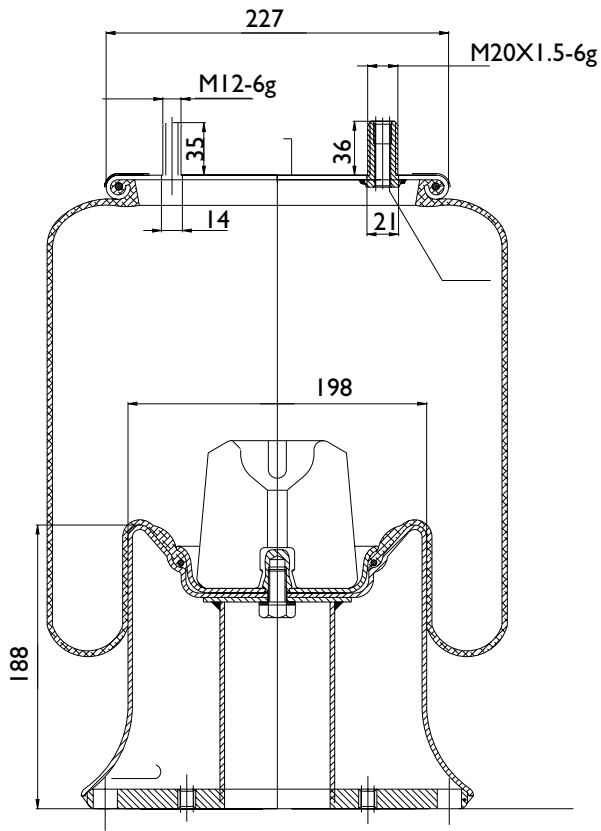
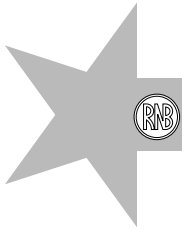

311025 Vista dall'alto

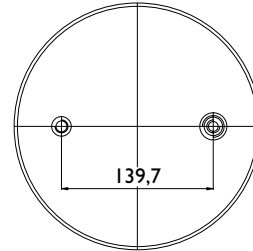

Vista dal basso

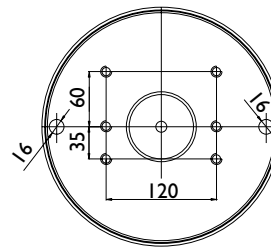

### Applicazioni principali

### Lista corrispondenze

CONTITECH	
FIRESTONE	IT 15 M-9
PHOENIX	
TAURUS	
DUNLOP UK	
DUNLOP F	
GOODYEAR	
PIRELLI	
GART	

⊗ Entrata aria

⊗ Perno combinato

# MOLLE AD ARIA COMPLETE



## AIRTECH® 34159-04 K

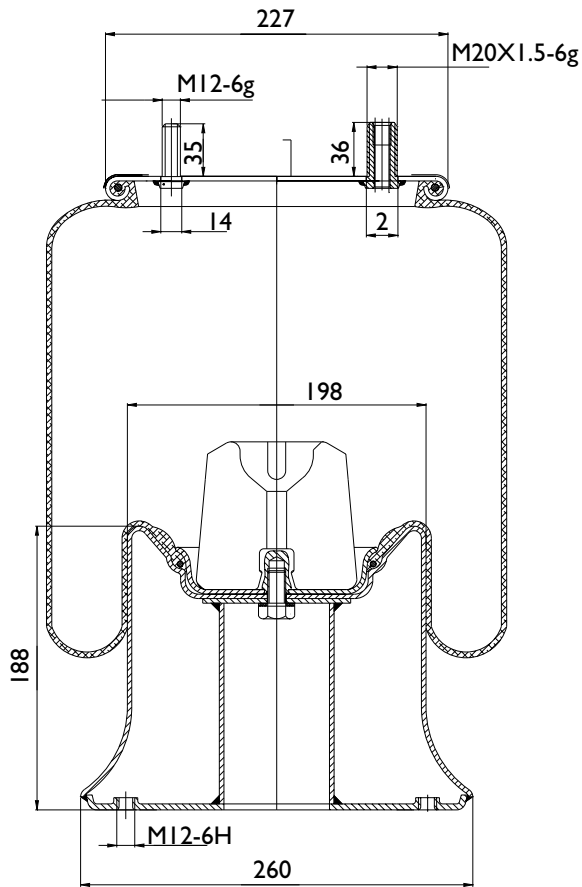

311025 Vista dall'alto

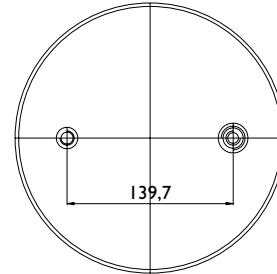

312009 Vista dal basso

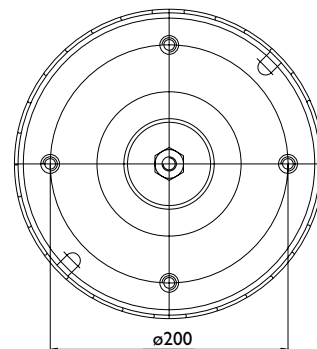

### Applicazioni principali

NEWAY	M00557007

### Lista corrispondenze

CONTITECH	
FIRESTONE	IT 15 M-9/W01 M58 9222
PHOENIX	
TAURUS	
DUNLOP UK	
DUNLOP F	
GOODYEAR	
PIRELLI	
GART	

⊗ Entrata aria

⊗ Perno combinato



**A520128C**

**AIRTECH® 34159-05 K**

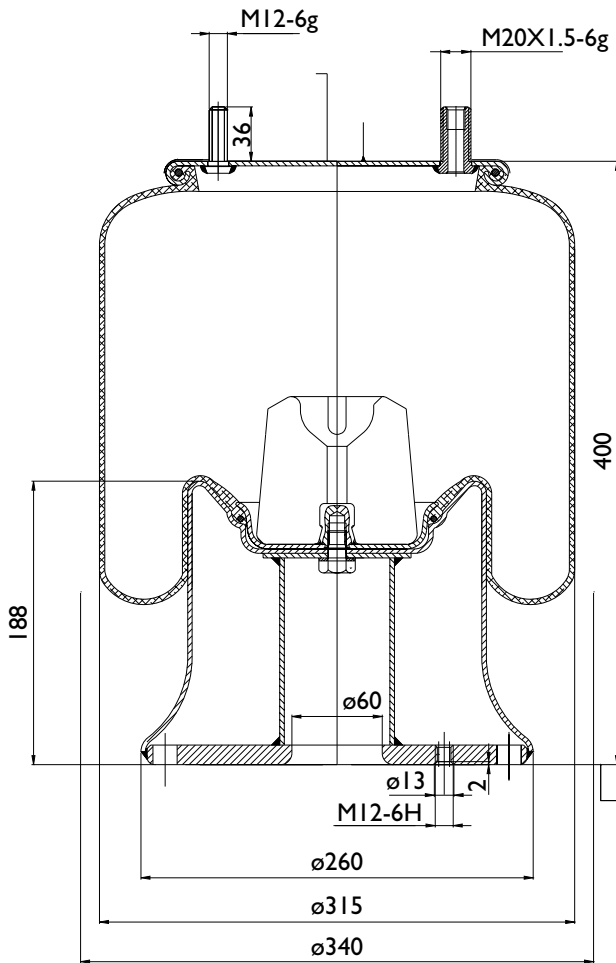

311026 Vista dall'alto

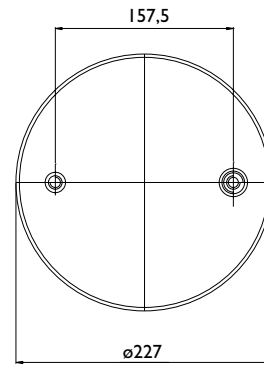

312067 Vista dal basso

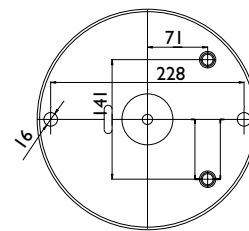

## Applicazioni principali

FRUEHAUF	UJB0203-001

## Lista corrispondenze

CONTITECH	4159 NP 07
FIRESTONE	1 T 15M9/W01 M58/8859/379-9091
PHOENIX	1 DK 21 B6
TAURUS	KR 509-9091
DUNLOP UK	
DUNLOP F	D 12 B01
GOODYEAR	1 R 12-702
PIRELLI	1 T 323-40 / 202302
GART	D278/H (278.2.511)

⊗ Entrata aria

⊗ Perno combinato

# MOLLE AD ARIA COMPLETE



## AIRTECH® 34159-07 K

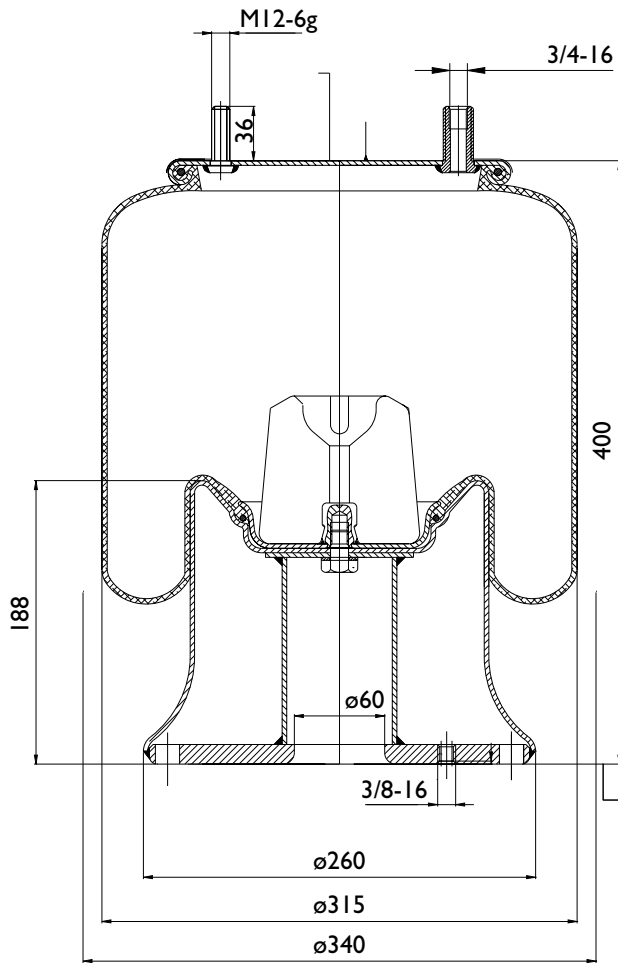

311023 Vista dall'alto

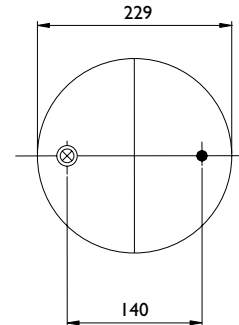

312077 Vista dal basso

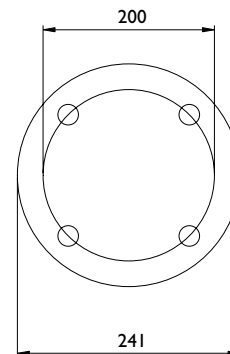

### Applicazioni principali

HENDRICKSON	B3842
ERF	139275-4
NEWAY	90557008
NEWAY	90557009
NEWAY	90557082

### Lista corrispondenze

CONTITECH	
FIRESTONE	
PHOENIX	
TAURUS	
DUNLOP UK	
DUNLOP F	
GOODYEAR	I R 12-103
PIRELLI	
GART	

⊗ Entrata aria

⊗ Perno combinato

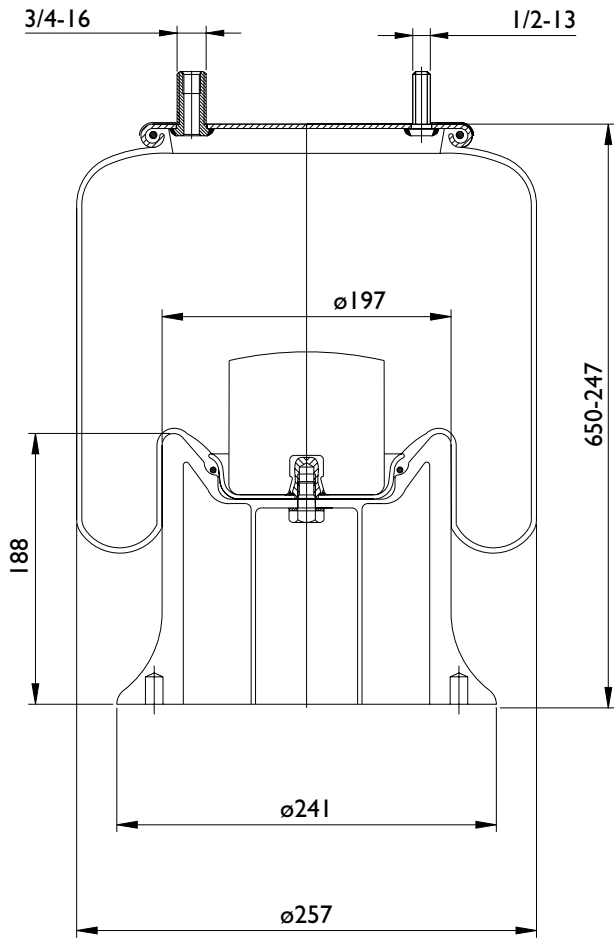

311086 Vista dall'alto

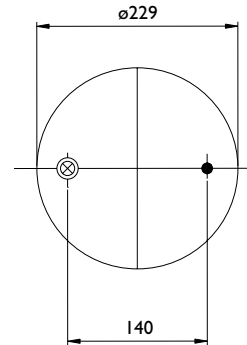

312006 Vista dal basso

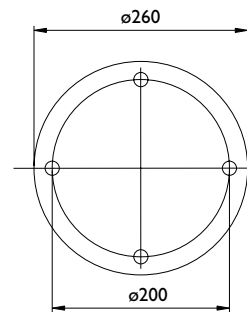

### Applicazioni principali

HENDRICKSON	B6195
NEWAY	90557086

### Lista corrispondenze

CONTITECH	
FIRESTONE	I T 15 M-9 / W01 358 9192
PHOENIX	
TAURUS	
DUNLOP UK	
DUNLOP F	
GOODYEAR	I R 12-167
PIRELLI	
GART	

⊗ Entrata aria

⊗ Perno combinato

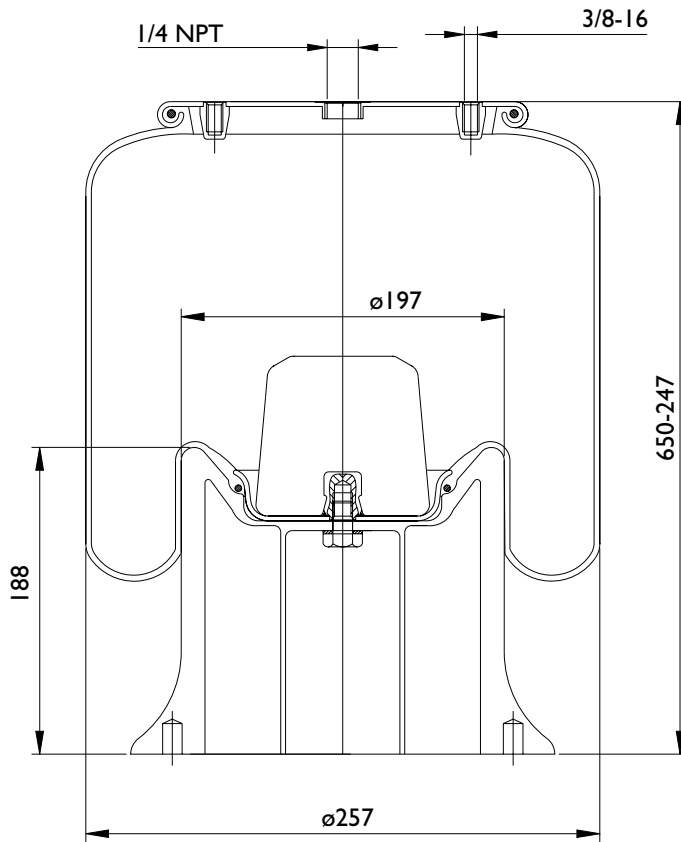

311087 Vista dall'alto

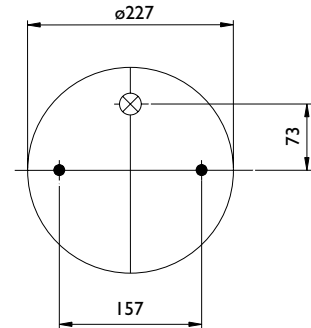

312009 Vista dal basso

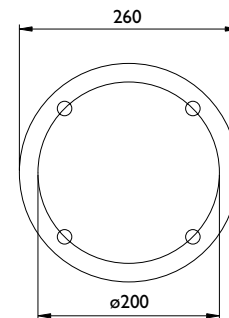

### Applicazioni principali

SCANIA+SCANIA BUSSAR	255294

### Lista corrispondenze

CONTITECH	
FIRESTONE	I T 15 M-9 / W01 358 9104
PHOENIX	
TAURUS	
DUNLOP UK	
DUNLOP F	
GOODYEAR	
PIRELLI	
GART	

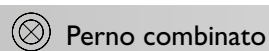



**A520093**

**AIRTECH® 34390-01**

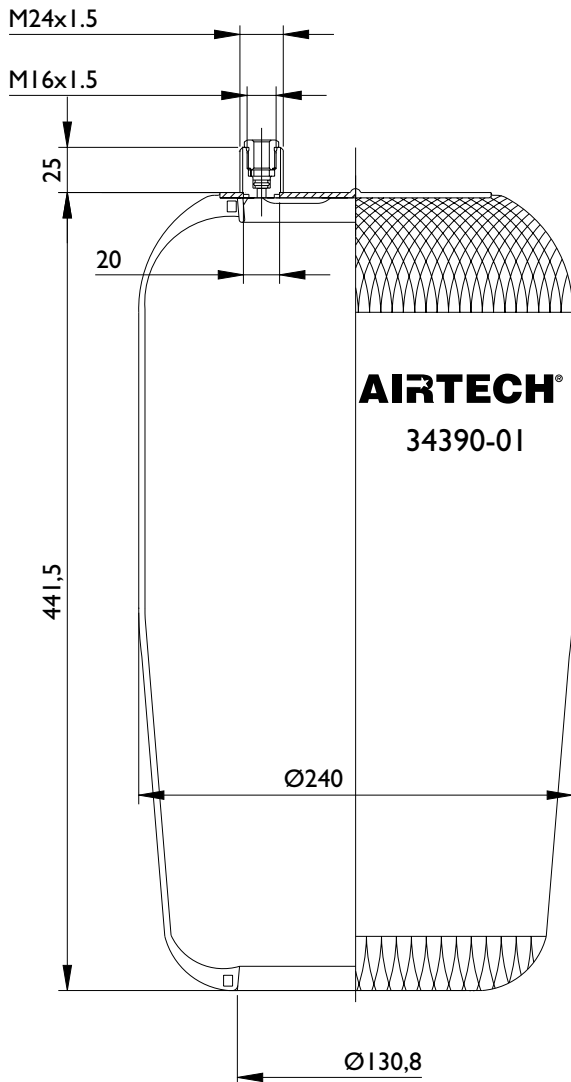

314001 Vista dall'alto

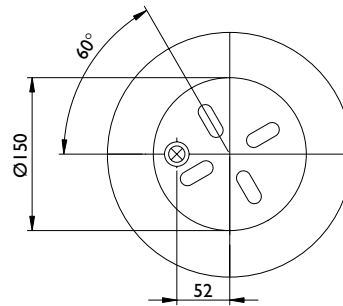

### Applicazioni principali

DAIMLER CHRYSLER (ACTROS)	A 942.320.01.21
DAIMLER CHRYSLER (ACTROS)	A 942.327.00.01
DAIMLER CHRYSLER (ACTROS)	A 942.328.00.01

### Lista corrispondenze

CONTITECH	4390 NI
FIRESTONE	
PHOENIX	
TAURUS	
DUNLOP UK	
DUNLOP F	
GOODYEAR	
PIRELLI	I VSC 285-30 206 782
GART	

⊗ Entrata aria

⊗ Perno combinato



# MOLLE AD ARIA COMPLETE



A520093C

AIRTECH® 34390-01 K

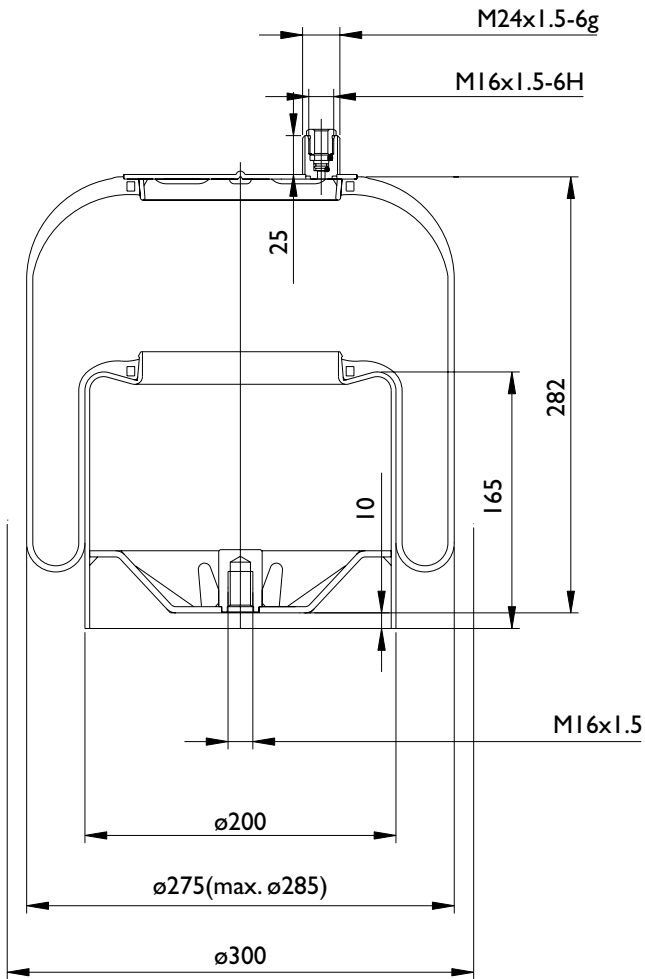

314001 Vista dall'alto

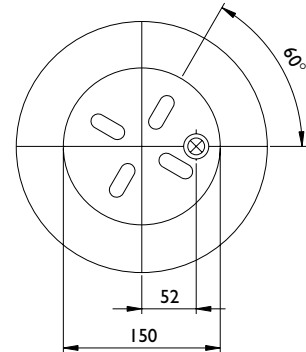

312032 Vista dal basso

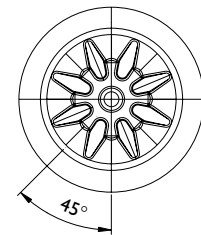

## Applicazioni principali

DAIMLER CHRYSLER	A 942.320.01.21

## Lista corrispondenze

CONTITECH	4390 NP 01
FIRESTONE	
PHOENIX	
TAURUS	
DUNLOP UK	
DUNLOP F	
GOODYEAR	
PIRELLI	
GART	

⊗ Entrata aria

⊗ Perno combinato

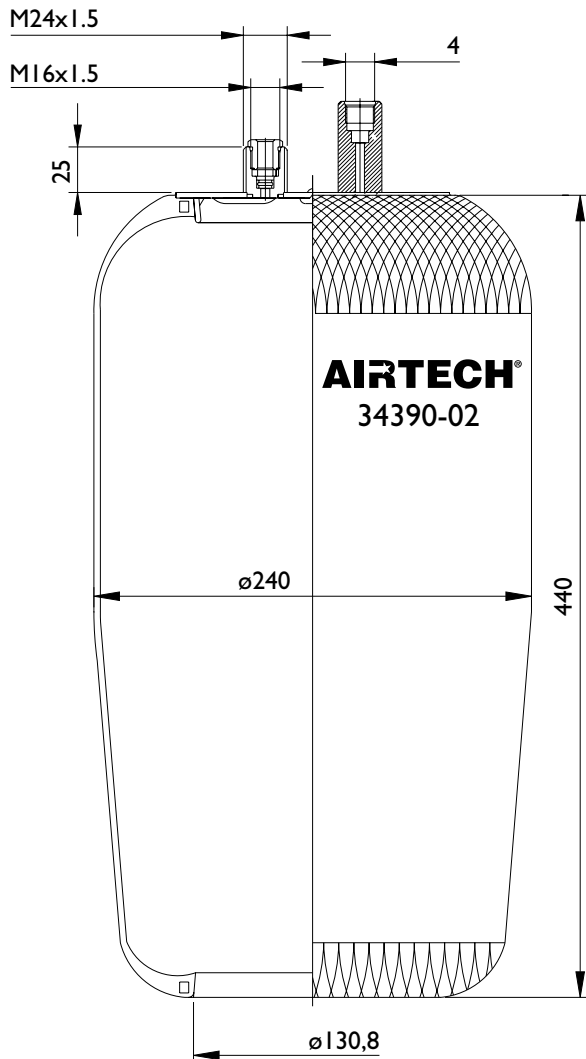

311004 Vista dall'alto

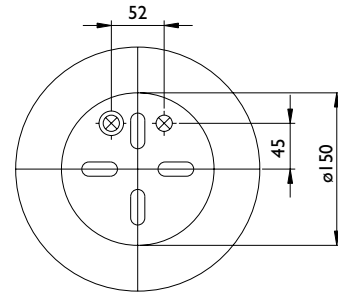

### Applicazioni principali

DAIMLER CHRYSLER	A942.320.02.21

### Lista corrispondenze

CONTITECH	4390 NP 02
FIRESTONE	
PHOENIX	
TAURUS	
DUNLOP UK	
DUNLOP F	
GOODYEAR	
PIRELLI	
GART	

⊗ Entrata aria

⊗ Perno combinato

# MOLLE AD ARIA COMPLETE



A520098C

**AIRTECH®** 34390-02 K

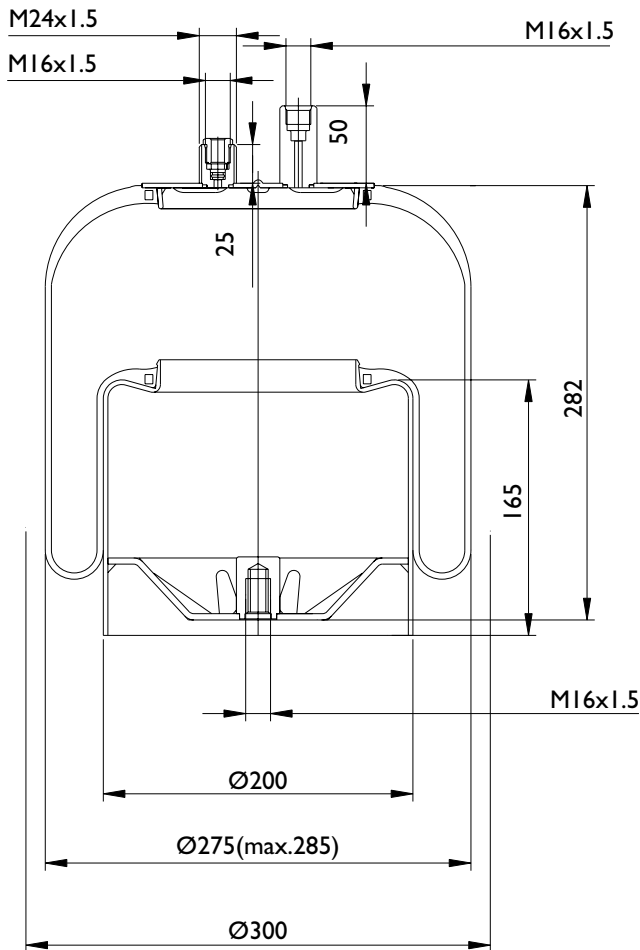

314002 Vista dall'alto

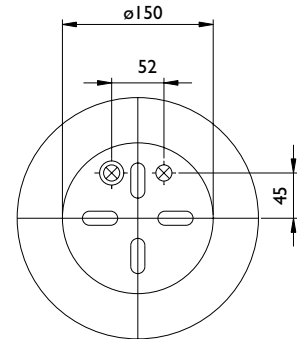

312032 Vista dal basso

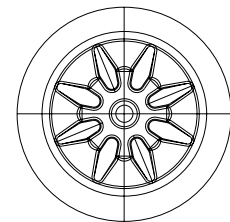

## Applicazioni principali

DAIMLER CHRYSLER	A 942.320.02.21

## Lista corrispondenze

CONTITECH	4390 NP 02
FIRESTONE	
PHOENIX	
TAURUS	
DUNLOP UK	
DUNLOP F	
GOODYEAR	
PIRELLI	
GART	

⊗ Entrata aria

⊗ Perno combinato



**A520164C**

**AIRTECH® 34420K**

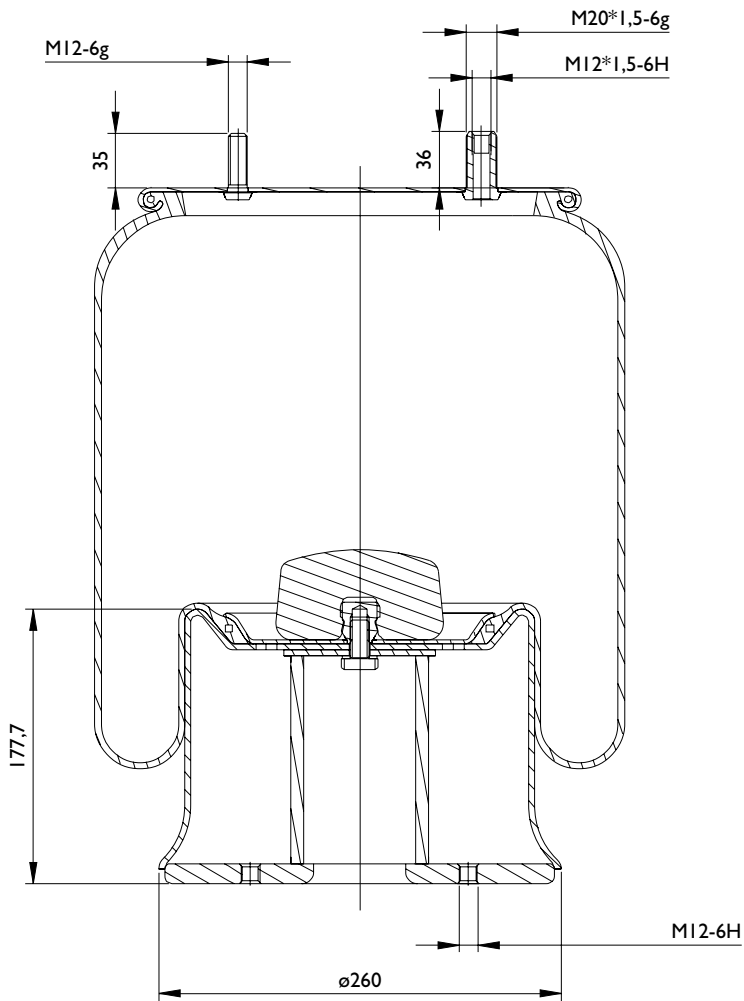

311103 Vista dall'alto

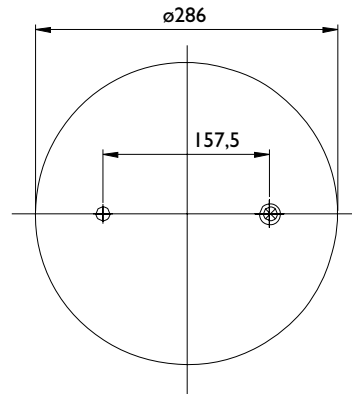

312111 Vista dal basso

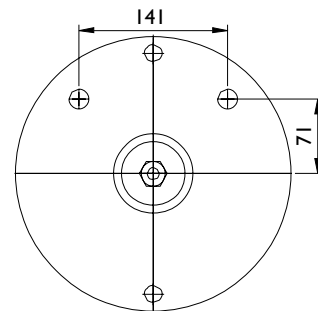

## Applicazioni principali

FRUEHAUF	431487

## Lista corrispondenze

CONTITECH	
FIRESTONE	
PHOENIX	
TAURUS	
DUNLOP UK	
DUNLOP F	
GOODYEAR	
PIRELLI	IT 19 E-2 204420
GART	

⊗ Entrata aria

⊗ Perno combinato

# MOLLE AD ARIA SEMI-COMPLETE



A520072

**AIRTECH® 34713**

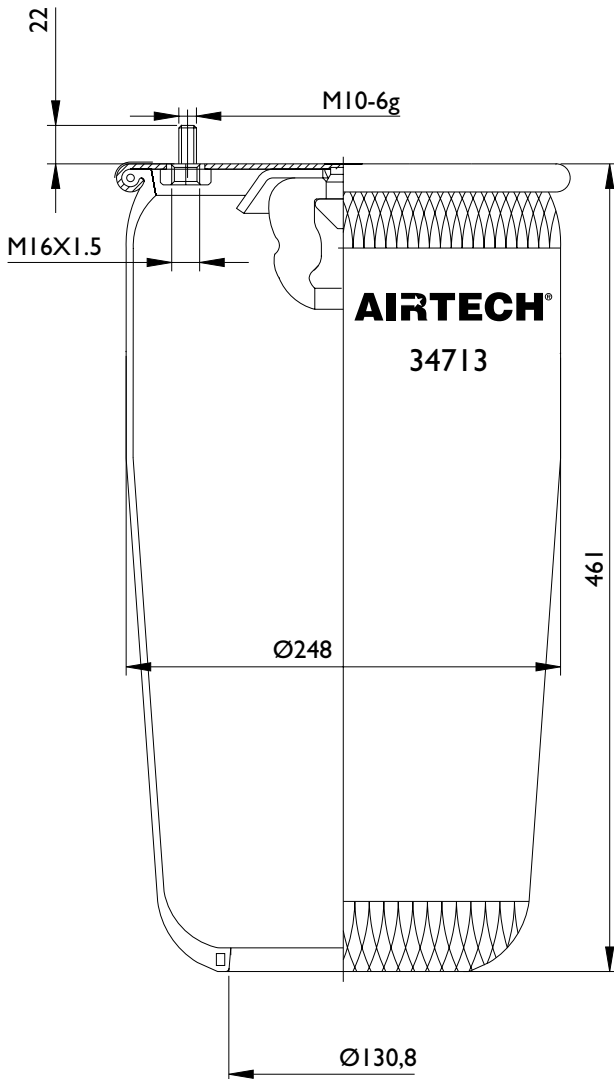

311037 Vista dall'alto

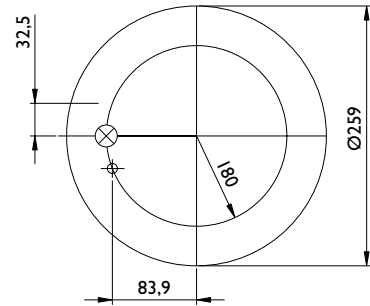

## Applicazioni principali

VOLVO	1076595
VOLVO	8158106

## Lista corrispondenze

CONTITECH	4713 N
FIRESTONE	
PHOENIX	
TAURUS	
DUNLOP UK	
DUNLOP F	
GOODYEAR	
PIRELLI	
GART	

⊗ Entrata aria

⊗ Perno combinato



**A520072C**

**AIRTECH® 34713 K**

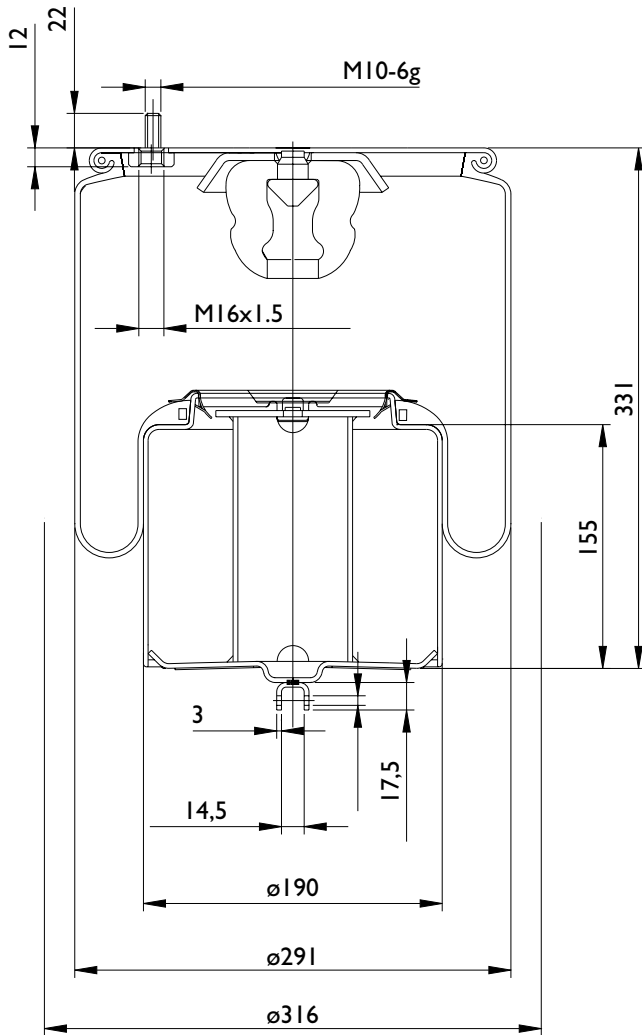

311037 Vista dall'alto

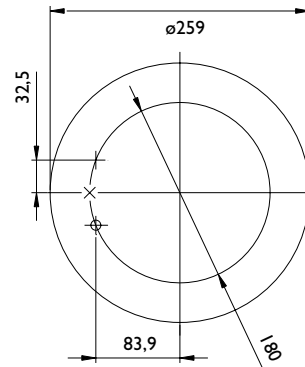

312074 Vista dal basso

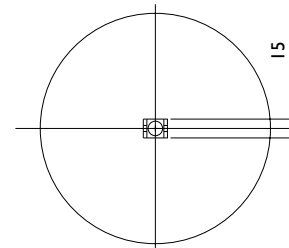

## Applicazioni principali

VOLVO	I076594

## Lista corrispondenze

CONTITECH	4713 NP 02
FIRESTONE	
PHOENIX	
TAURUS	
DUNLOP UK	
DUNLOP F	
GOODYEAR	I R 12-762
PIRELLI	
GART	

⊗ Entrata aria

⊗ Perno combinato

# MOLLE AD ARIA COMPLETE



A520121C

AIRTECH® 34718 K

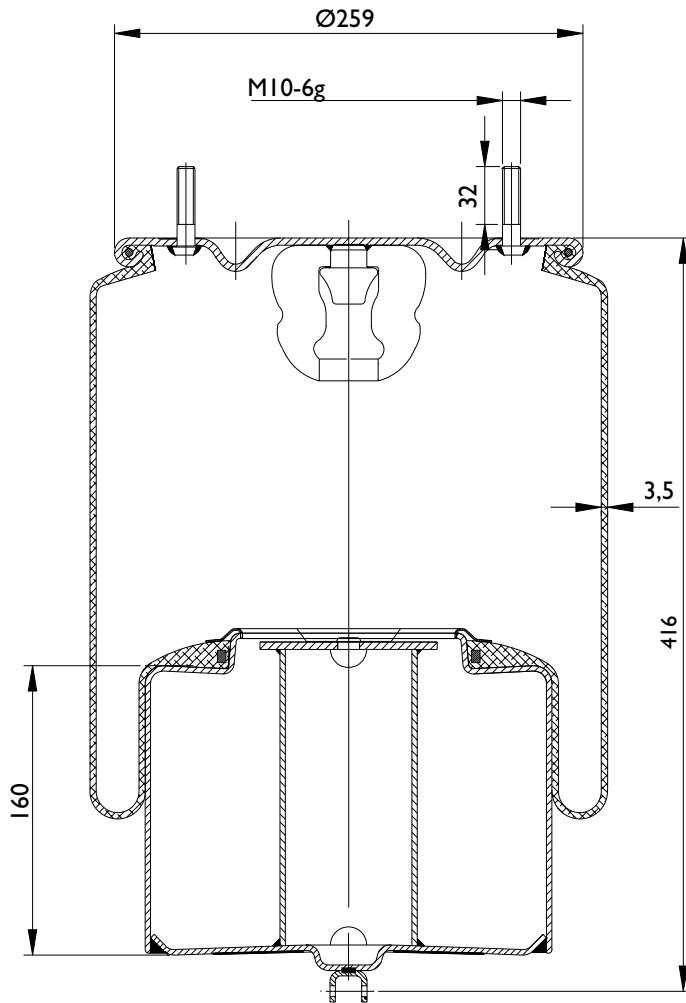

311115 Vista dall'alto

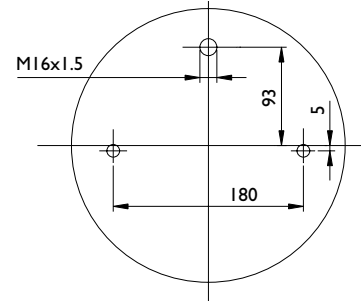

312068 Vista dal basso

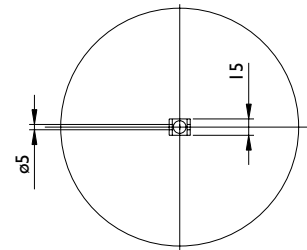

## Applicazioni principali

VOLVO	1075363
VOLVO	1629718

## Lista corrispondenze

CONTITECH	4718 N
FIRESTONE	
PHOENIX	
TAURUS	
DUNLOP UK	
DUNLOP F	
GOODYEAR	
PIRELLI	
GART	

⊗ Entrata aria

⊗ Perno combinato

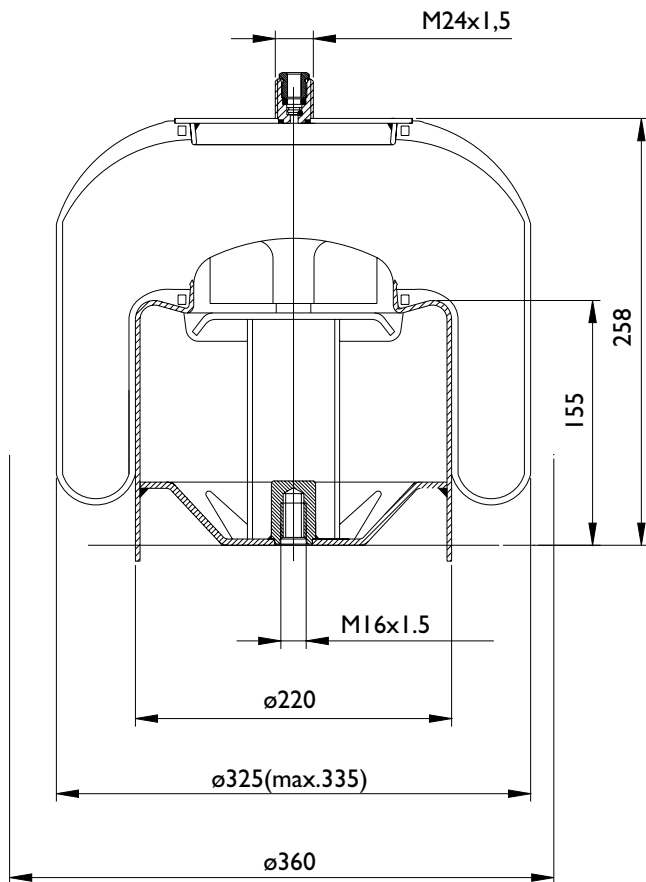

Vista dall'alto

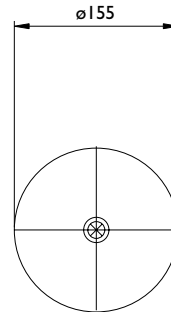

312087 Vista dal basso

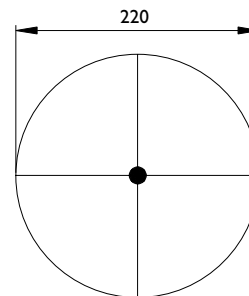

### Applicazioni principali

DAIMLER CHRYSLER	A 946.320.03.21

### Lista corrispondenze

CONTITECH	4737 NP 01
FIRESTONE	
PHOENIX	
TAURUS	
DUNLOP UK	
DUNLOP F	
GOODYEAR	
PIRELLI	
GART	

⊗ Entrata aria

⊗ Perno combinato



# MOLLE AD ARIA COMPLETE



## AIRTECH® 34737-02 K

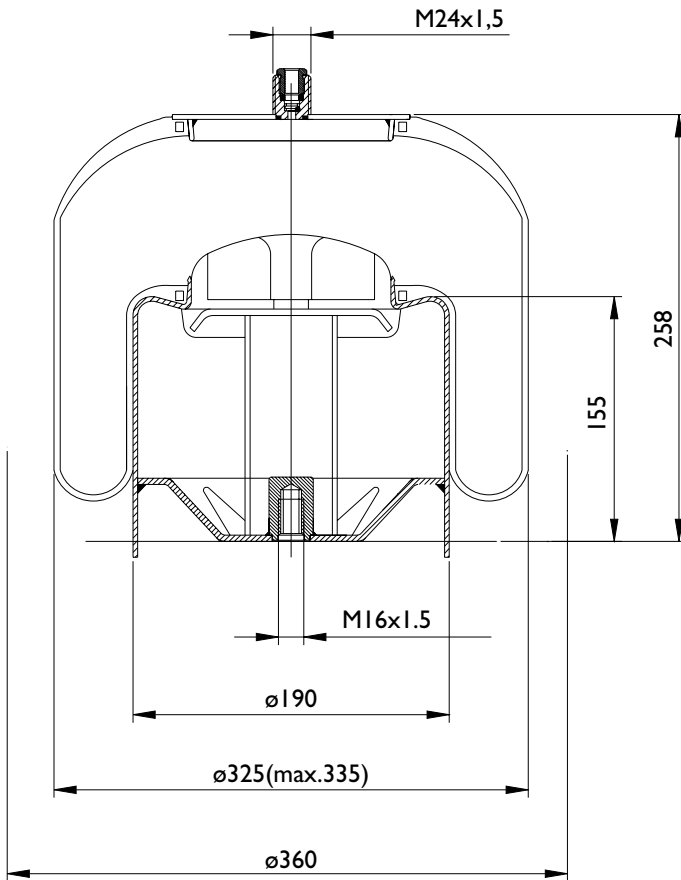

Vista dall'alto

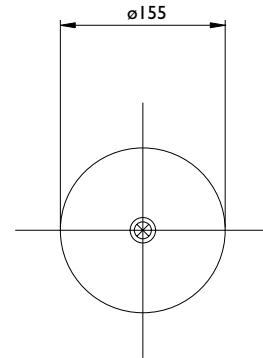

312088 Vista dal basso

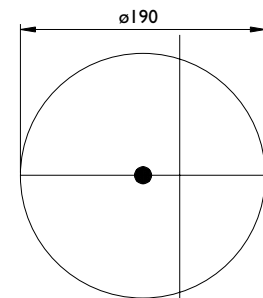

### Applicazioni principali

DAIMLER CHRYSLER	A 946.320.05.21

### Lista corrispondenze

CONTITECH	4737 NP 02
FIRESTONE	
PHOENIX	
TAURUS	
DUNLOP UK	
DUNLOP F	
GOODYEAR	
PIRELLI	
GART	

⊗ Entrata aria

⊗ Perno combinato

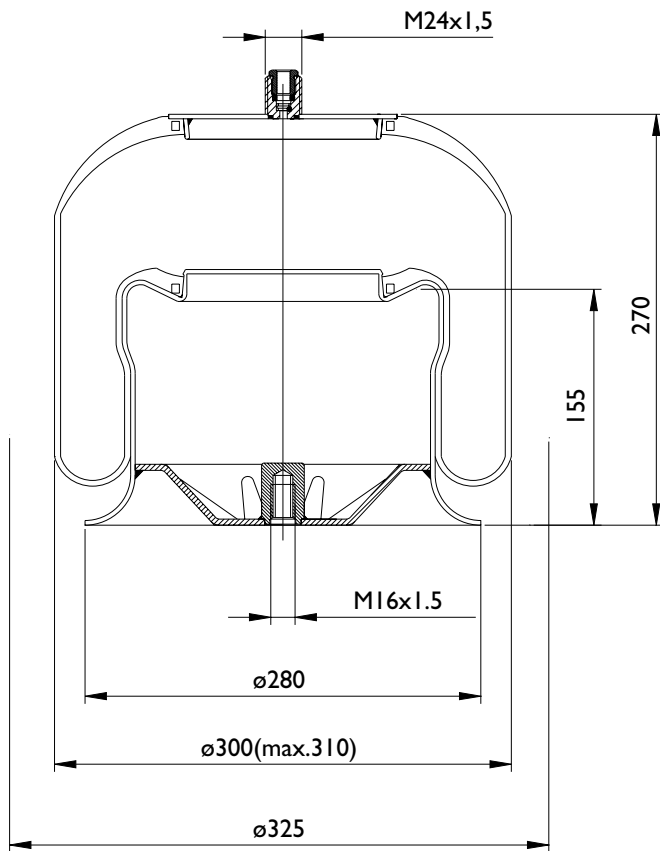
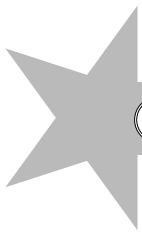

Vista dall'alto

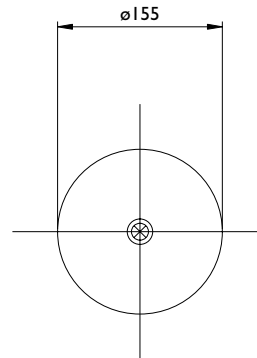

312086 Vista dal basso

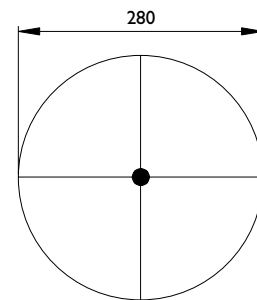

### Applicazioni principali

DAIMLER CHRYSLER	A 942.320.01.17

### Lista corrispondenze

CONTITECH	4757 NP 01
FIRESTONE	
PHOENIX	
TAURUS	
DUNLOP UK	
DUNLOP F	
GOODYEAR	
PIRELLI	
GART	

⊗ Entrata aria

⊗ Perno combinato

# MOLLE AD ARIA COMPLETE



**AIRTECH® 34757-02 K**

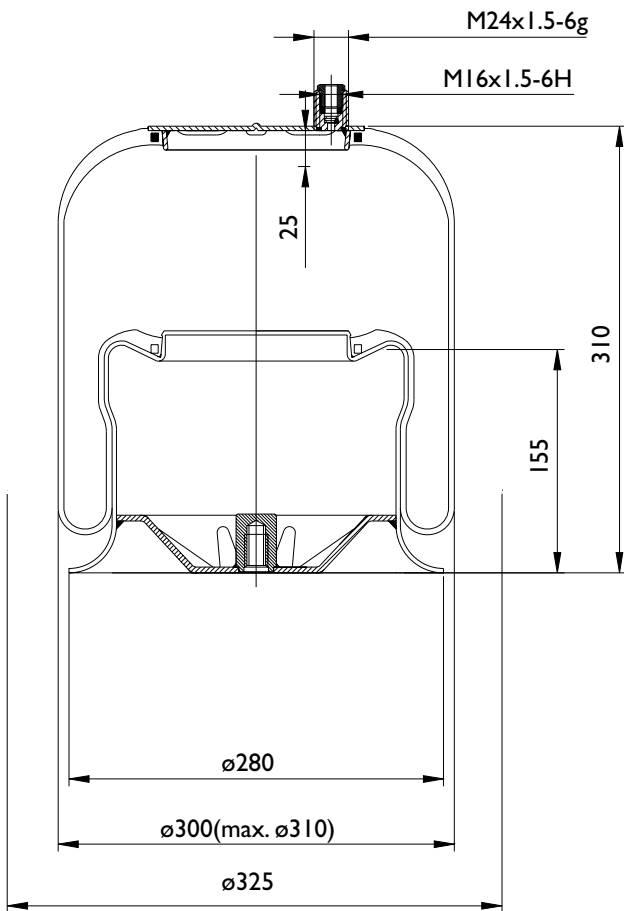

Vista dall'alto

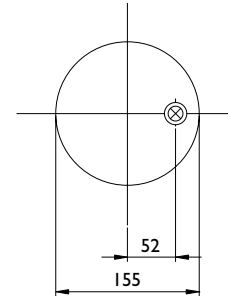

312086 Vista dal basso

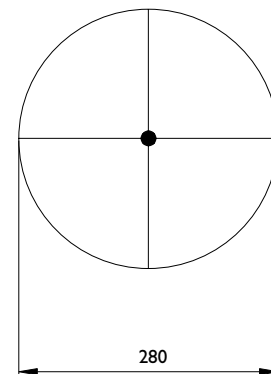

## Applicazioni principali

DAIMLER CHRYSLER	A 942.320.02.17

## Lista corrispondenze

CONTITECH	4757 NP 02
FIRESTONE	
PHOENIX	
TAURUS	
DUNLOP UK	
DUNLOP F	
GOODYEAR	
PIRELLI	
GART	

⊗ Entrata aria

⊗ Perno combinato

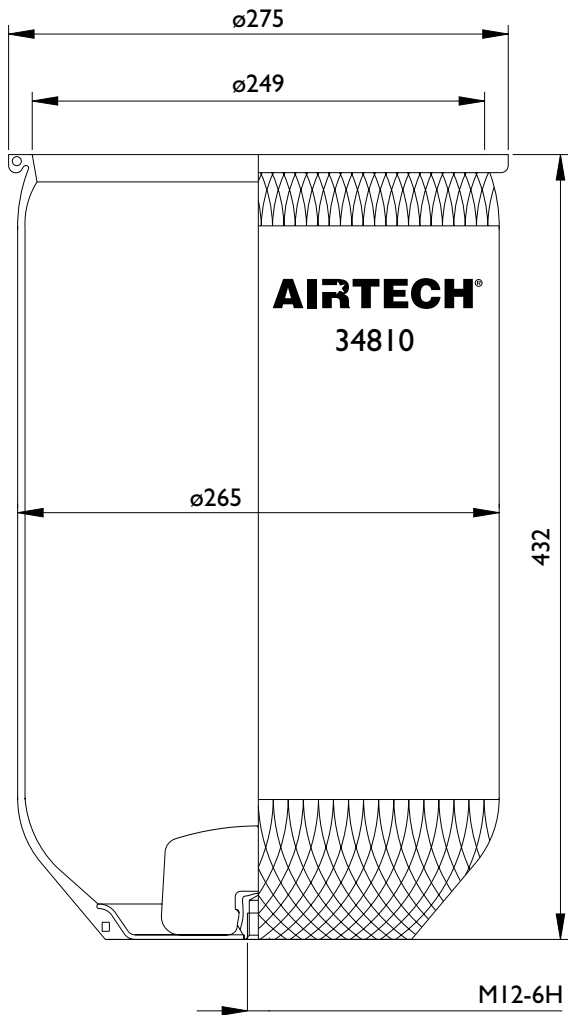
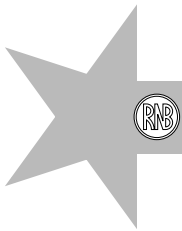

315002 Vista dal basso

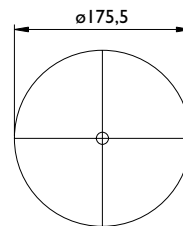

### Applicazioni principali

MAN	81.43601.6019
PEGASO	174933

### Lista corrispondenze

CONTITECH	810 NTB
FIRESTONE	1 T 19 L-7 / W01 M58 0749
PHOENIX	
TAURUS	
DUNLOP UK	
DUNLOP F	
GOODYEAR	1 R 14-713
PIRELLI	1T19E1-93702
GART	

⊗ Entrata aria

⊗ Perno combinato

# MOLLE AD ARIA SEMI-COMPLETE



## AIRTECH® 34813

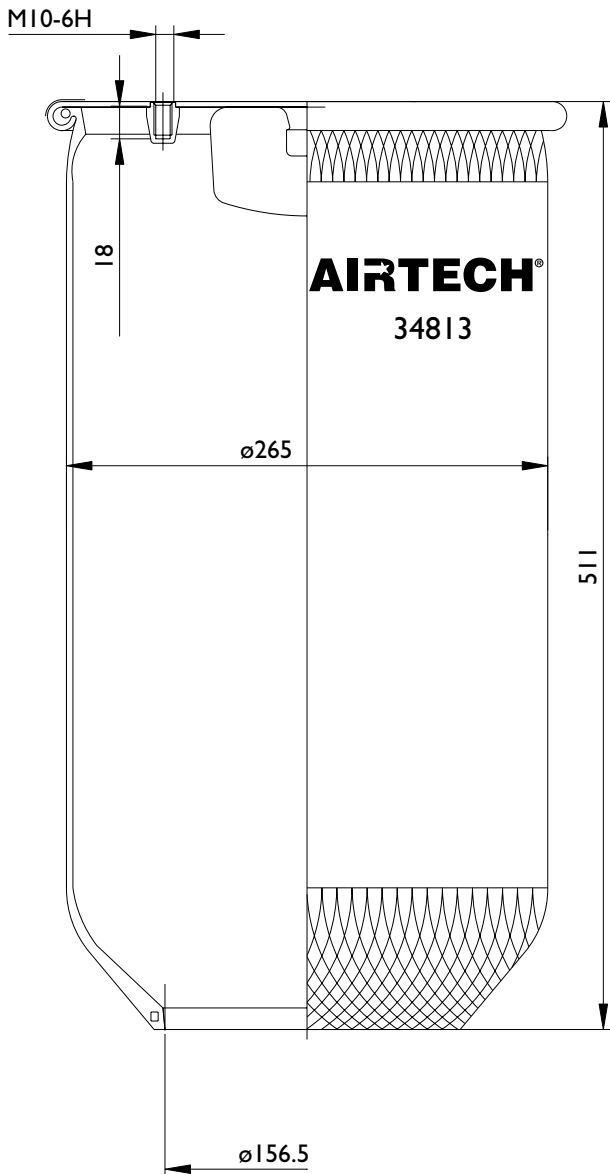

311014 Vista dall'alto

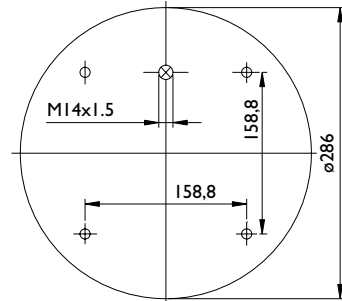

### Applicazioni principali

SCANIA	255.293
SCANIA	255.295
SCANIA	298.568
SCANIA	325.748
SCANIA	1.107.674
SCANIA	1.314.906

### Lista corrispondenze

CONTITECH	4813 NP 07
FIRESTONE	1 T 19 L-11
PHOENIX	ID28B-9
TAURUS	KR622-01
DUNLOP UK	
DUNLOP F	D13 B10
GOODYEAR	IR14-727
PIRELLI	IT19 E2BR
GART	D287 (4.520)

⊗ Entrata aria

⊗ Perno combinato

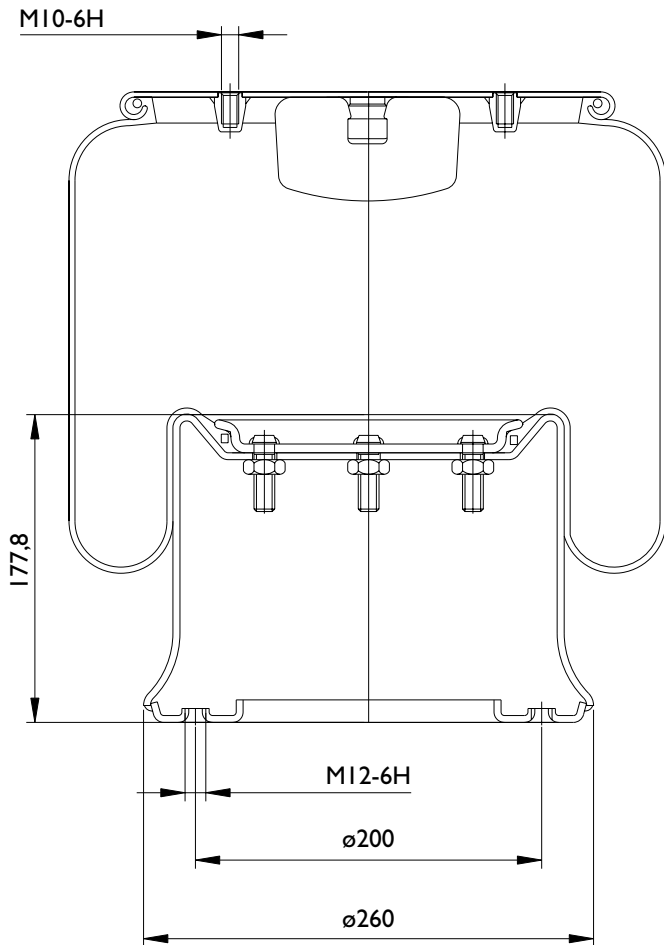

311014 Vista dall'alto

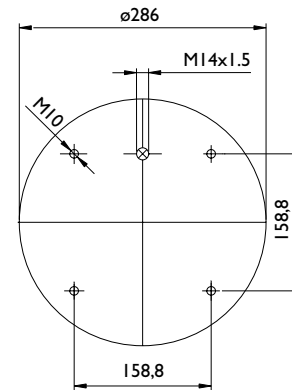

312014 Vista dal basso

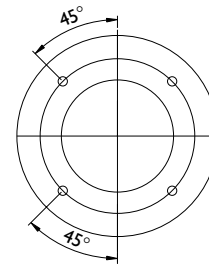

### Applicazioni principali

SAF	3.229.0006.01
SCANIA	1107674
SCANIA	1314906
SCANIA	298568

### Lista corrispondenze

CONTITECH	4813 NP 07
FIRESTONE	1 T 19 L-11 / W01 S05 7358
PHOENIX	1 D 28 B-9
TAURUS	KR 622-01
DUNLOP UK	
DUNLOP F	D 13 B 10
GOODYEAR	1 R 14-727
PIRELLI	1 T 19 E-2 BR / 97764
GART	D287 287.0.520

⊗ Entrata aria

⊗ Perno combinato

# MOLLE AD ARIA SEMI-COMLETE



A520126

**AIRTECH® 34838**

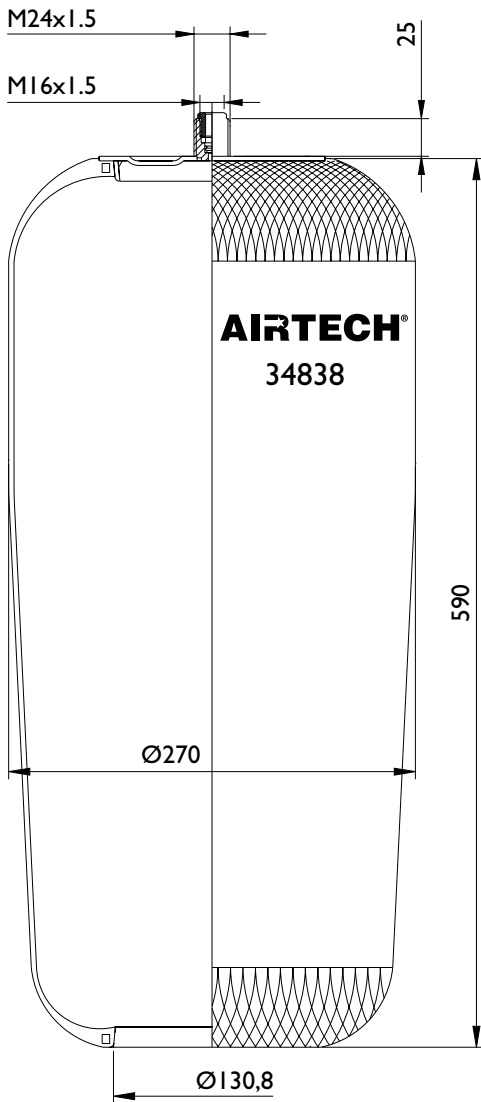

314003 Vista dall'alto

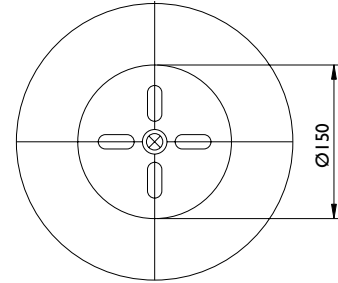

## Applicazioni principali

DAIMLER CHRYSLER serie ACTROS	A 946.320.04.21

## Lista corrispondenze

CONTITECH	4838 NP 03
FIRESTONE	
PHOENIX	
TAURUS	
DUNLOP UK	
DUNLOP F	
GOODYEAR	
PIRELLI	
GART	

⊗ Entrata aria

⊗ Perno combinato



A520030

**AIRTECH® 3488 I**

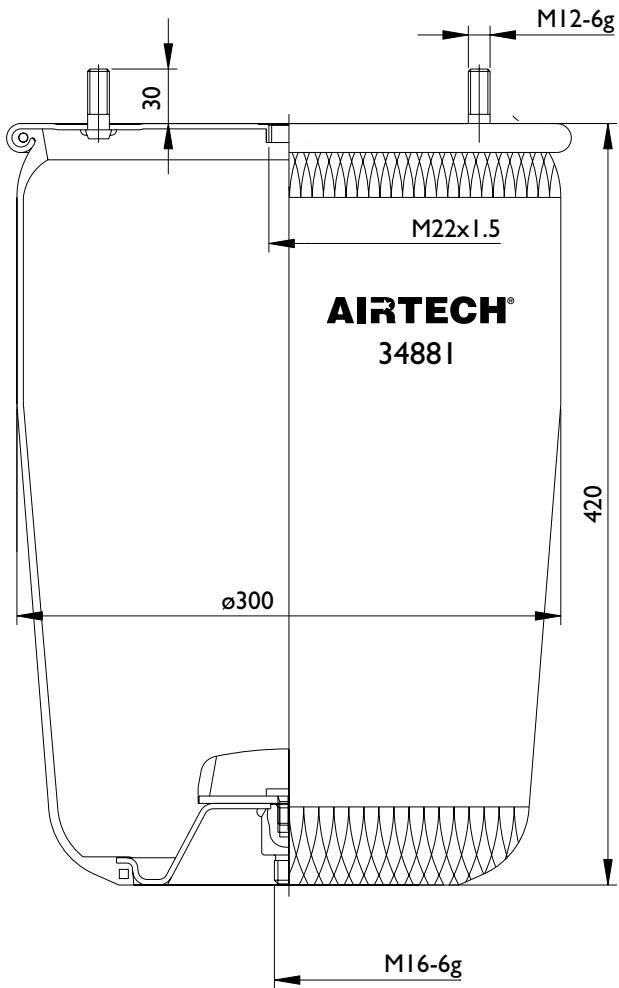

311019 Vista dall'alto

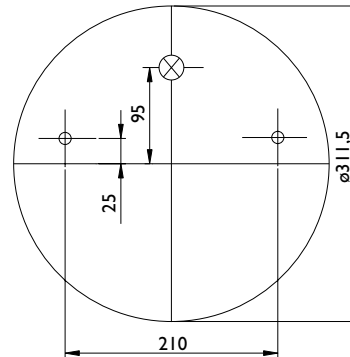

315004 Vista dal basso

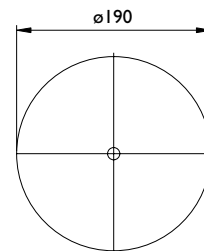

## Applicazioni principali

BPW	05.429.41.01.0

## Lista corrispondenze

CONTITECH	488 I NP 02
FIRESTONE	I T 66 D-7.0 / W01 M58 8601
PHOENIX	I DK 32 K
TAURUS	UR 838-01 T
DUNLOP UK	
DUNLOP F	D14 U37
GOODYEAR	IR 14-701
PIRELLI	ITC360-40 / 205537
GART	C292/A 292.0.461

⊗ Entrata aria

⊗ Perno combinato



# MOLLE AD ARIA COMPLETE

 **A520030C**

**AIRTECH® 34881-01 K**

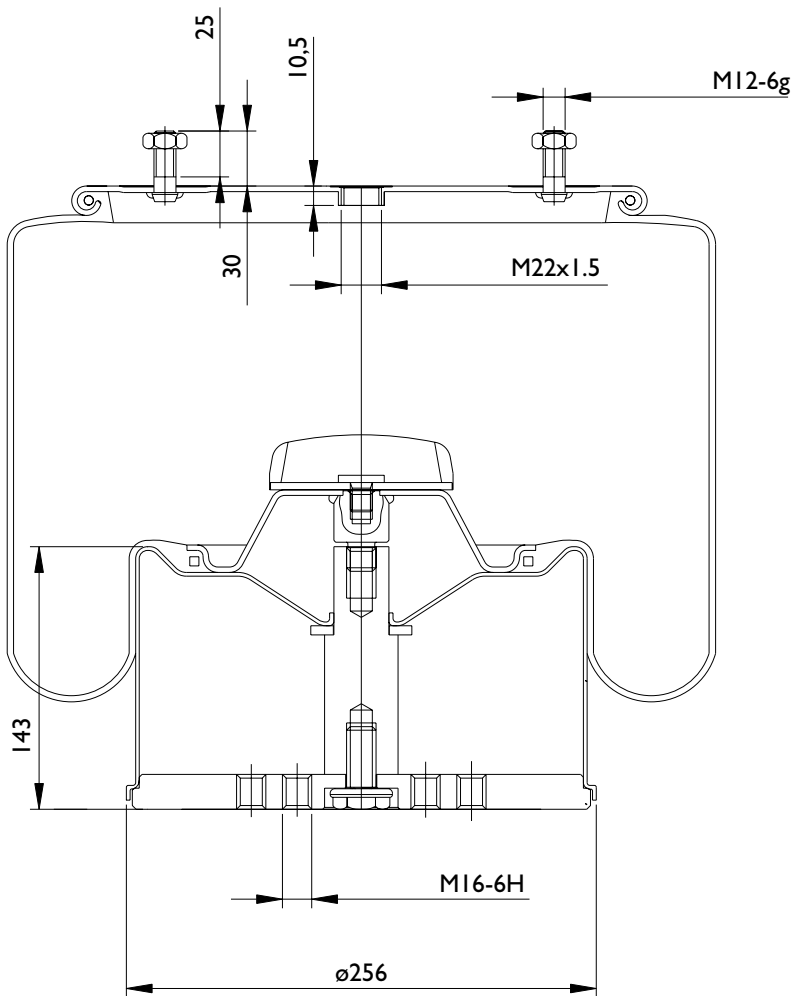

311019 Vista dall'alto

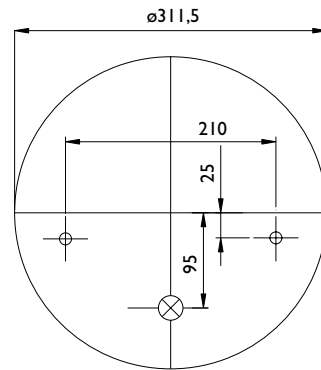

Vista dal basso

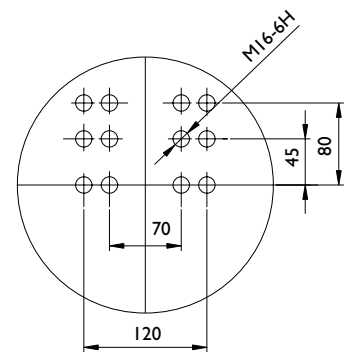



## Applicazioni principali

BPW	05.42941.010

## Lista corrispondenze

CONTITECH	4881 MB
FIRESTONE	IT66D-7.0 / W01 M58 8601
PHOENIX	IDK32K
TAURUS	UR83701
DUNLOP UK	
DUNLOP F	D14 B37
GOODYEAR	IR14-701
PIRELLI	ITC360-45
GART	

 Entrata aria

 Perno combinato

# MOLLE AD ARIA COMPLETE



A520130C

AIRTECH® 34881-01 KPP

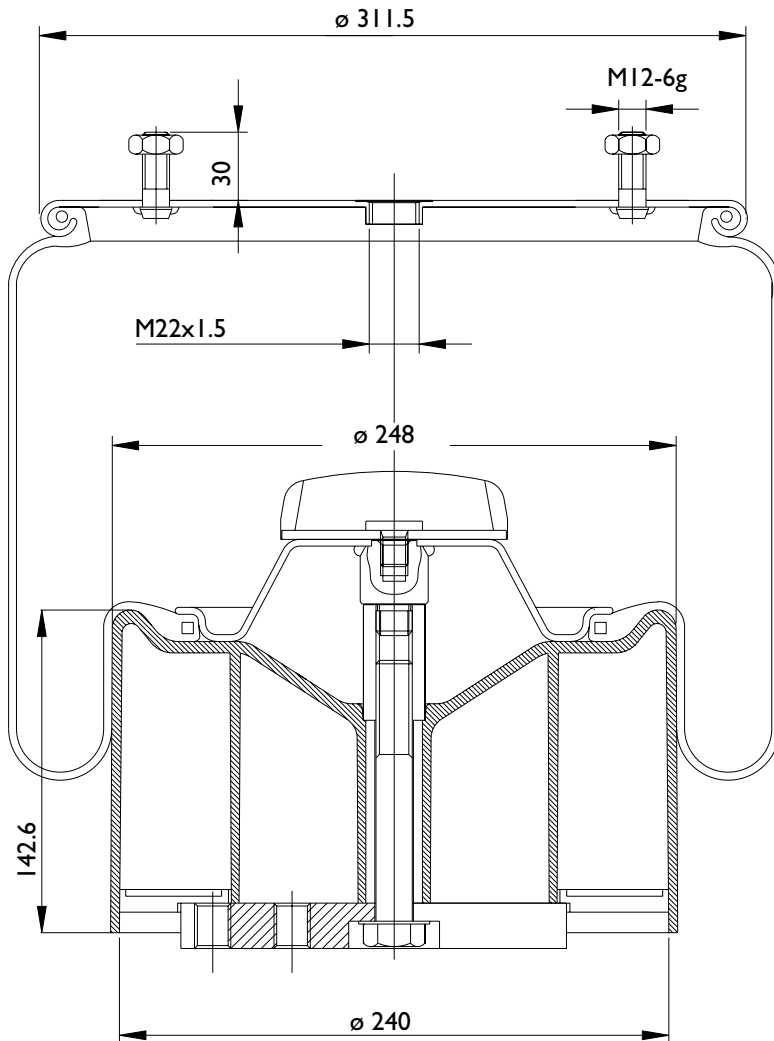

311019 Vista dall'alto

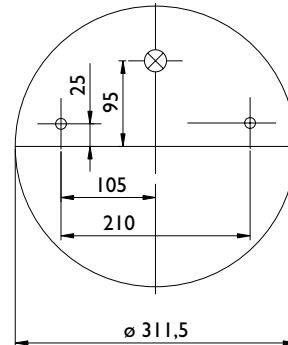

Vista dal basso

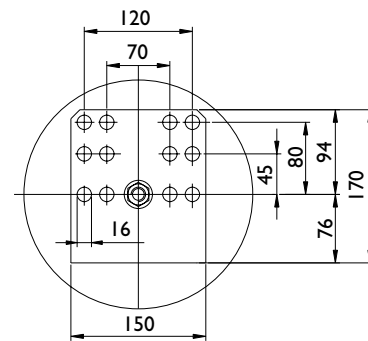

## Applicazioni principali

BPW	05.42943.410

## Lista corrispondenze

CONTITECH	4881MB
FIRESTONE	
PHOENIX	
TAURUS	
DUNLOP UK	
DUNLOP F	
GOODYEAR	
PIRELLI	ITC360-45 / 206357
GART	

⊗ Entrata aria

⊗ Perno combinato

# MOLLE AD ARIA SEMI-COMLETE



A520075

**AIRTECH® 34911**

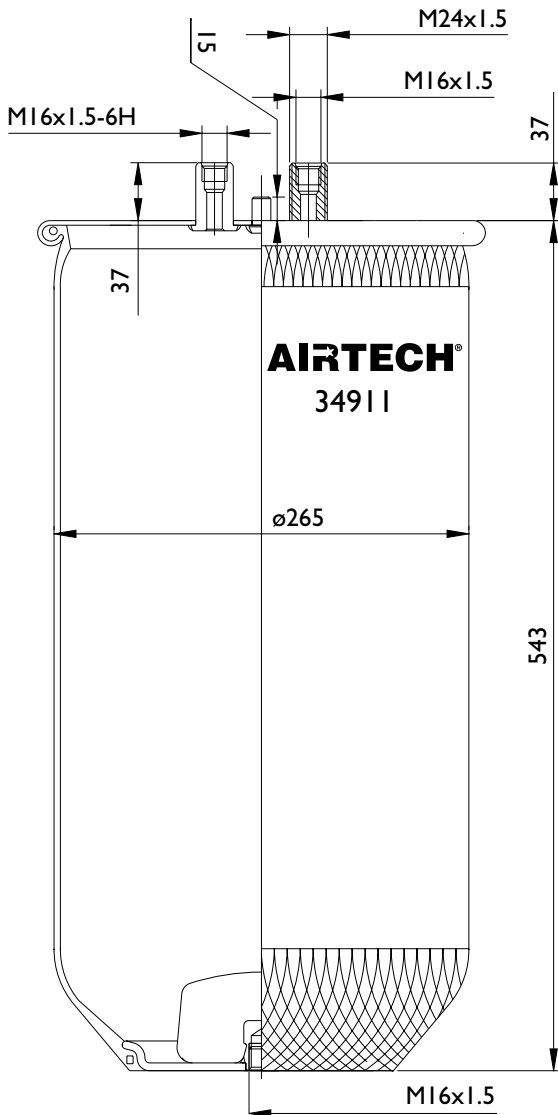

311090 Vista dall'alto

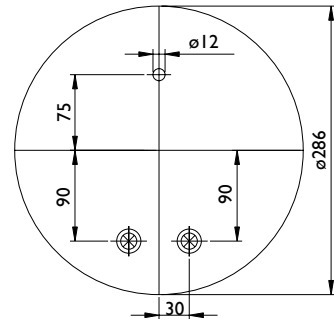

315009 Vista dal basso

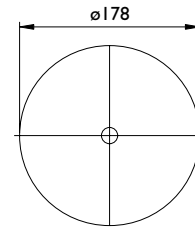

## Applicazioni principali

RVI	5.011.239.971
RVI	5.011.294.308

## Lista corrispondenze

CONTITECH	4911 N
FIRESTONE	
PHOENIX	
TAURUS	
DUNLOP UK	
DUNLOP F	
GOODYEAR	
PIRELLI	
GART	



Entrata aria



Perno combinato

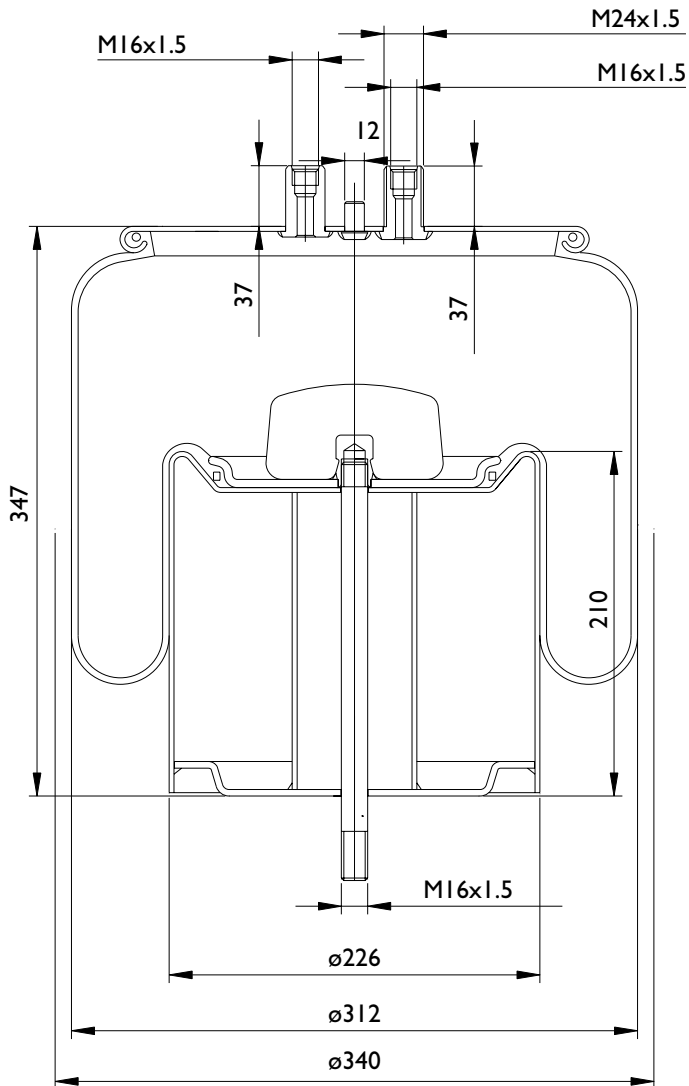

311090 Vista dall'alto

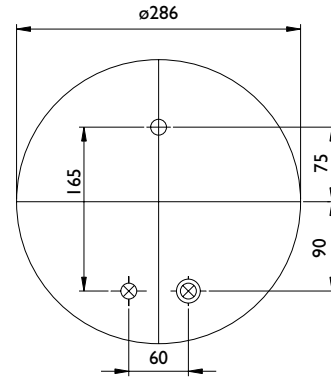

312039 Vista dal basso

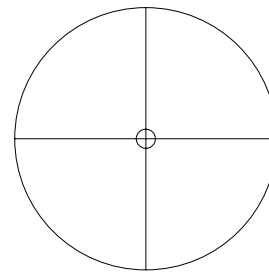

### Applicazioni principali

RVI	5.010.239.971

### Lista corrispondenze

CONTITECH	4911 NP 02
FIRESTONE	
PHOENIX	
TAURUS	
DUNLOP UK	
DUNLOP F	
GOODYEAR	
PIRELLI	
GART	

⊗ Entrata aria

⊗ Perno combinato

# MOLLE AD ARIA SEMI-COMLETE



A520060

**AIRTECH® 34912**

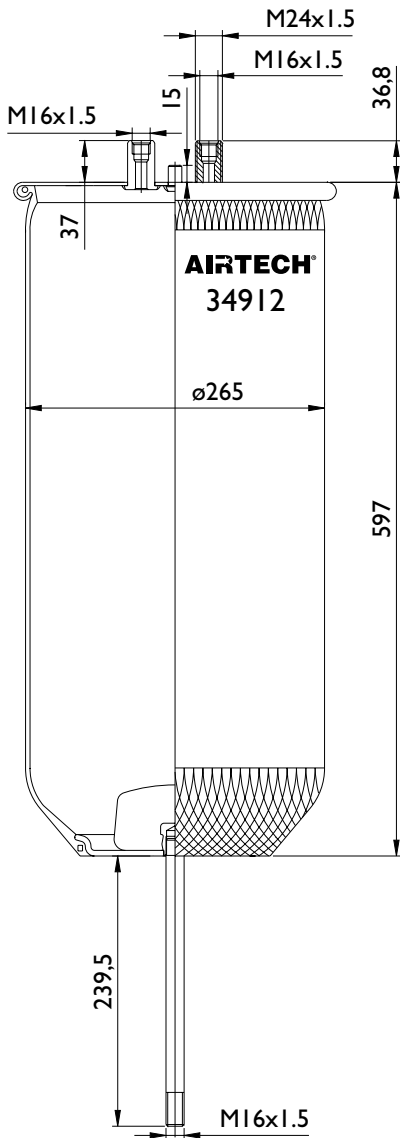

311090 Vista dall'alto

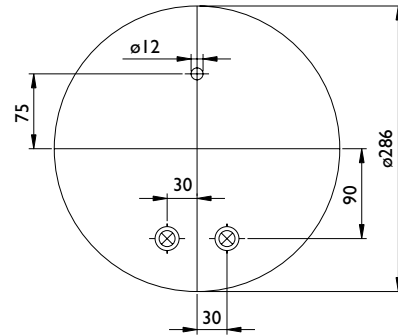

315009 Vista dal basso

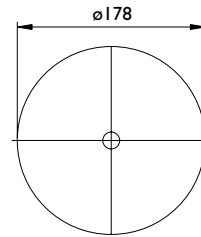

## Applicazioni principali

RVI	5.001.832.067
RVI	5.010.294.307

## Lista corrispondenze

CONTITECH	4912 N P08
FIRESTONE	
PHOENIX	
TAURUS	
DUNLOP UK	
DUNLOP F	
GOODYEAR	
PIRELLI	I T 19 E4 206 780
GART	



Entrata aria



Perno combinato



**A520060C**

**AIRTECH® 34912 K**

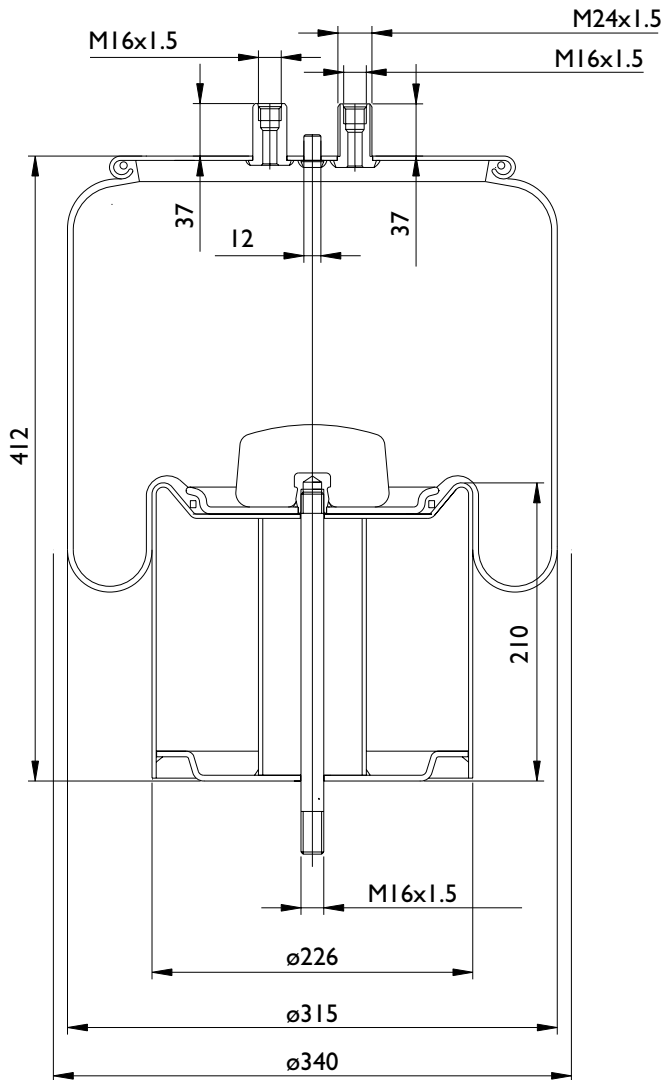

311090 Vista dall'alto

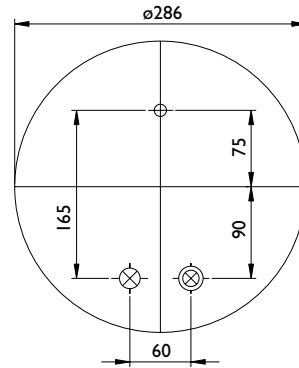

312039 Vista dal basso

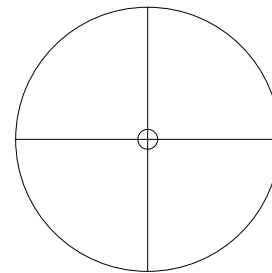

## Applicazioni principali

RVI	5.001.832.067
RVI	5.010.294.307 A/B

## Lista corrispondenze

CONTITECH	4912 NP 07
FIRESTONE	
PHOENIX	
TAURUS	
DUNLOP UK	
DUNLOP F	
GOODYEAR	I R 13-711
PIRELLI	I T 19 E4 206 779
GART	

⊗ Entrata aria

⊗ Perno combinato

# MOLLE AD ARIA SEMI-COMLETE



A520045

**AIRTECH® 34913**

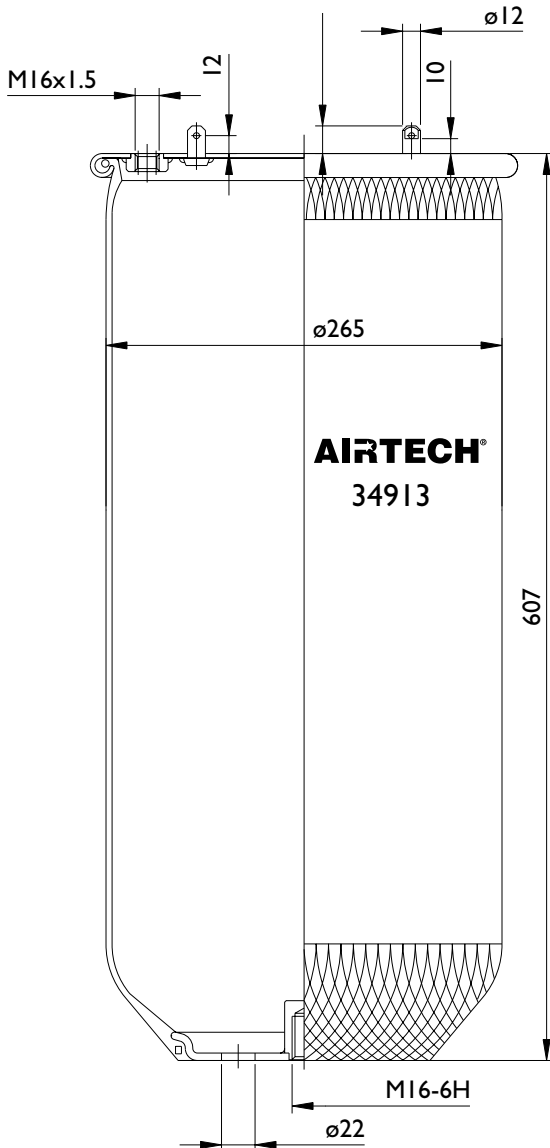

311092 Vista dall'alto

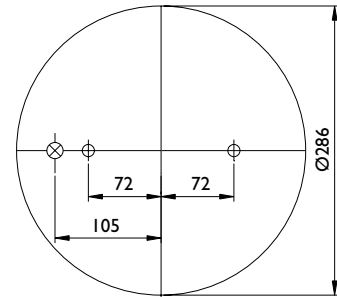

315008 Vista dal basso

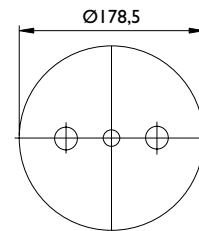

## Applicazioni principali

SCANIA+SCANIA BUSSAR	137 93 92
SCANIA+SCANIA BUSSAR	137 93 93
SCANIA+SCANIA BUSSAR	144 02 94

## Lista corrispondenze

CONTITECH	4913 NP 02
FIRESTONE	IT 19 F-14 / W01 095 0366
PHOENIX	
TAURUS	
DUNLOP UK	
DUNLOP F	
GOODYEAR	
PIRELLI	IT19E-93 / 206201
GART	



Entrata aria



Perno combinato

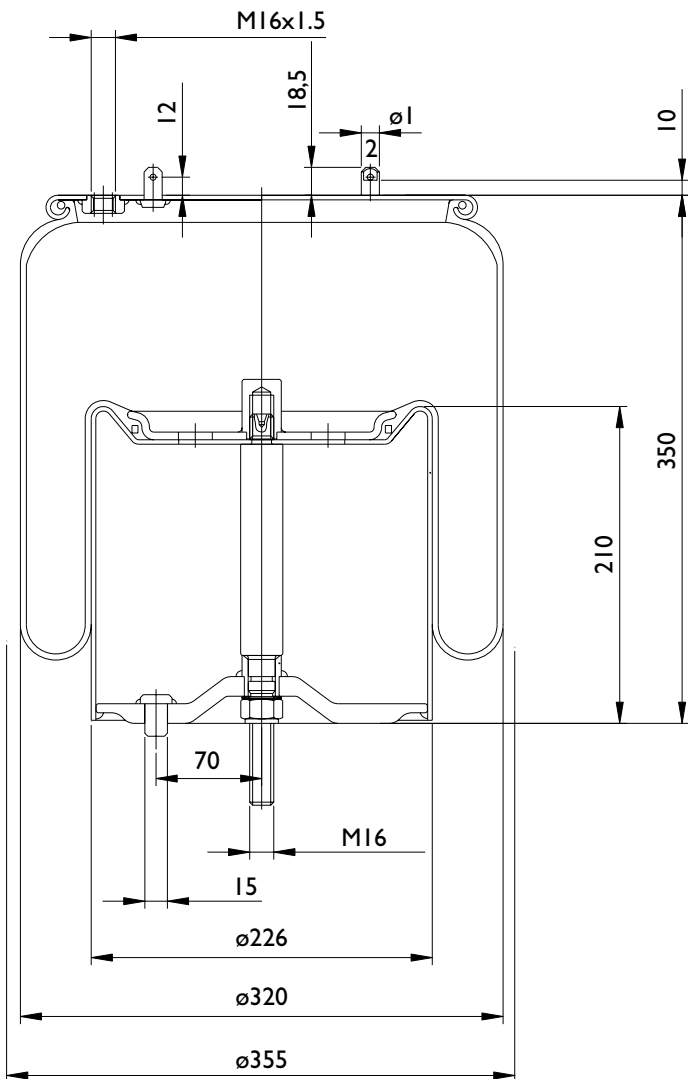

311092 Vista dall'alto

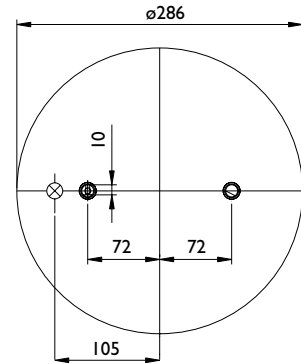

312070 Vista dal basso

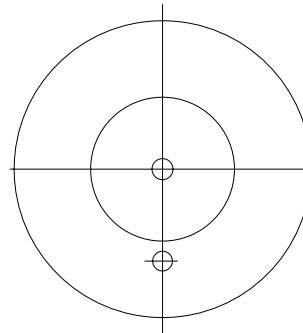

### Applicazioni principali

SCANIA+SCANIA BUSSAR	137 93 92
SCANIA+SCANIA BUSSAR	137 93 93
SCANIA+SCANIA BUSSAR	144 02 94

### Lista corrispondenze

CONTITECH	4913 NP 02
FIRESTONE	1 T 19 F-14 / W01 095 0366
PHOENIX	ID 28 H16
TAURUS	KR 625-16
DUNLOP UK	
DUNLOP F	
GOODYEAR	1 R 14-753
PIRELLI	IT19E-93 206 201
GART	C282/H 282.1.600

⊗ Entrata aria

⊗ Perno combinato



# MOLLE AD ARIA SEMI-COMLETE



A520112

AIRTECH® 34915

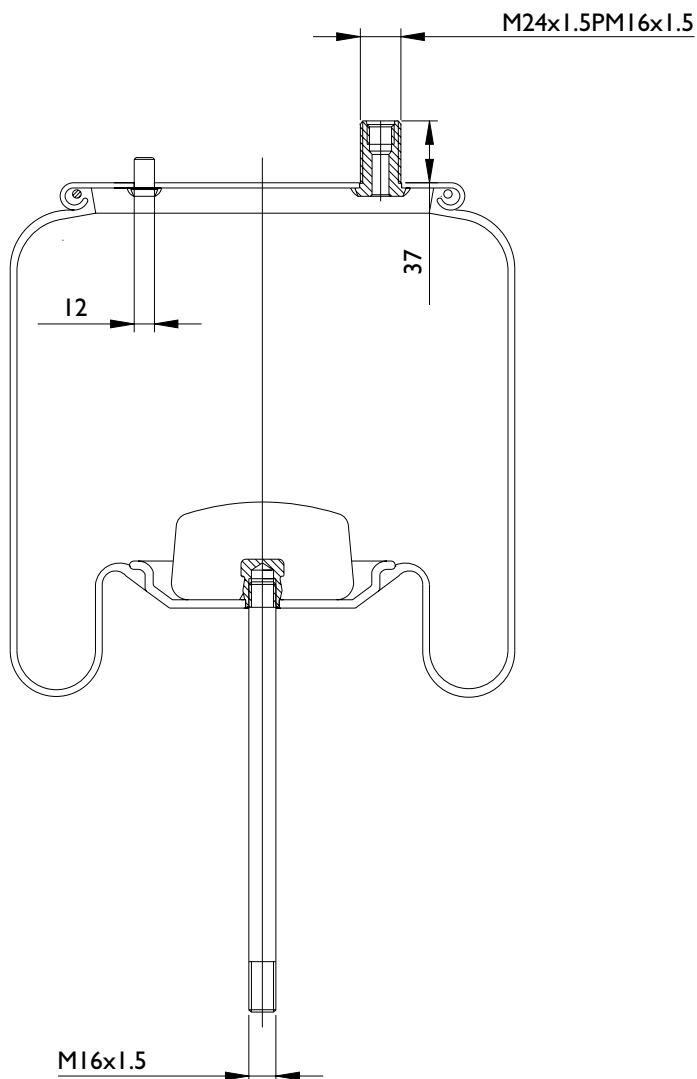

311126 Vista dall'alto

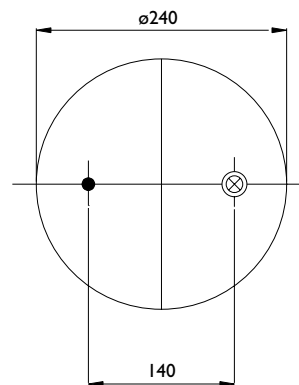

Vista dal basso

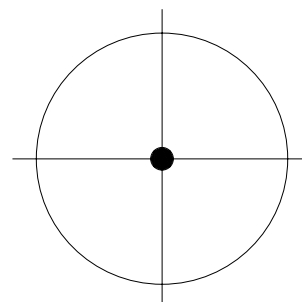

## Applicazioni principali

RVI PREMIUM G340T	50 01 855 856
RVI	50 10 294 546

## Lista corrispondenze

CONTITECH	4915 NP 03
FIRESTONE	
PHOENIX	
TAURUS	
DUNLOP UK	
DUNLOP F	
GOODYEAR	
PIRELLI	
GART	

⊗ Entrata aria

⊗ Perno combinato



**A520120C**

**AIRTECH® 34925 K**

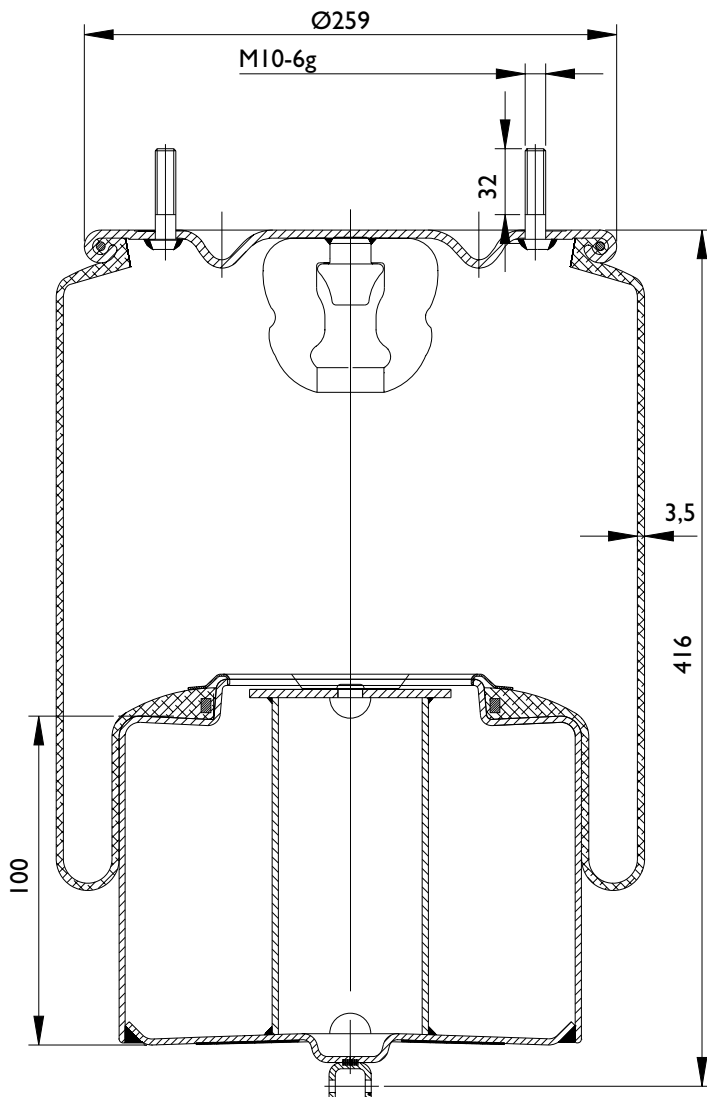

311115 Vista dall'alto

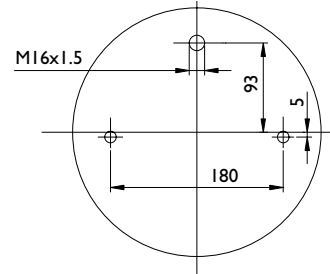

312068 Vista dal basso

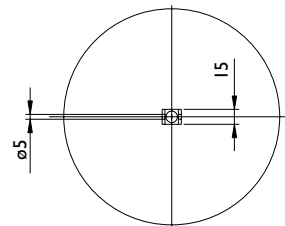

## Applicazioni principali

VOLVO	1075365
VOLVO	1629782

## Lista corrispondenze

CONTITECH	4925 N
FIRESTONE	
PHOENIX	
TAURUS	
DUNLOP UK	
DUNLOP F	
GOODYEAR	
PIRELLI	
GART	

⊗ Entrata aria

⊗ Perno combinato

# MOLLE AD ARIA SEMI-COMLETE



A520053

**AIRTECH® 34940**

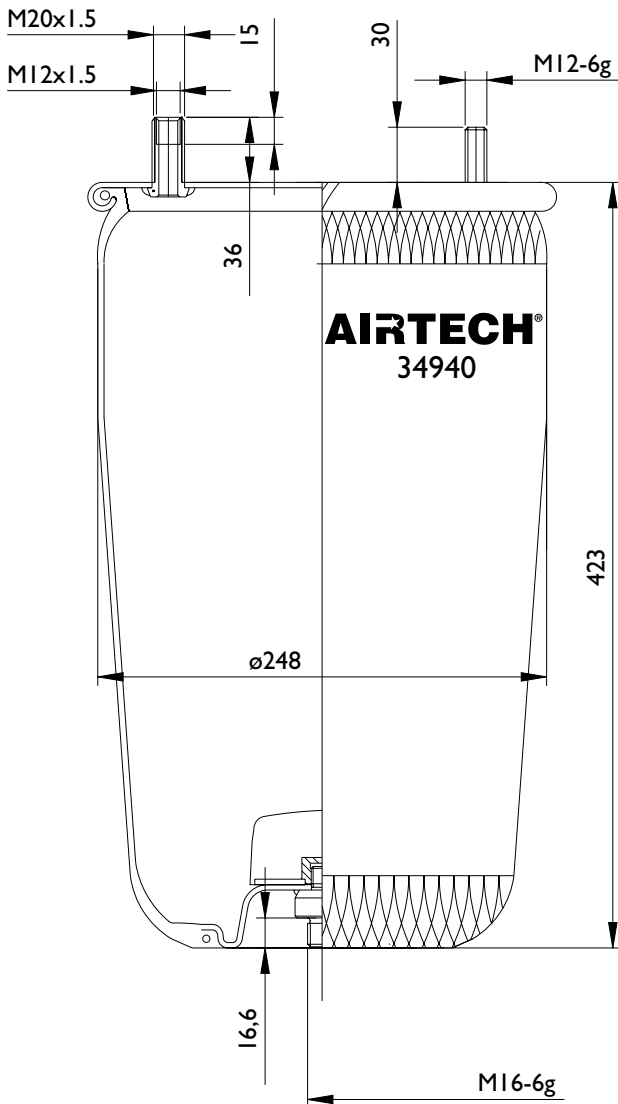

311046 Vista dall'alto

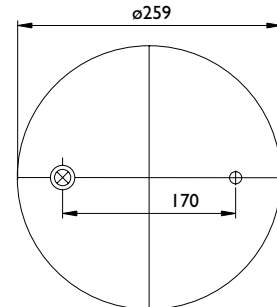

315003 Vista dal basso

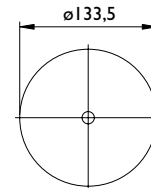

## Applicazioni principali

BPW	05.42941.560

## Lista corrispondenze

CONTITECH	4940 NP 02
FIRESTONE	
PHOENIX	
TAURUS	
DUNLOP UK	
DUNLOP F	
GOODYEAR	
PIRELLI	
GART	

⊗ Entrata aria

⊗ Perno combinato



**A520054**

**AIRTECH® 34941**

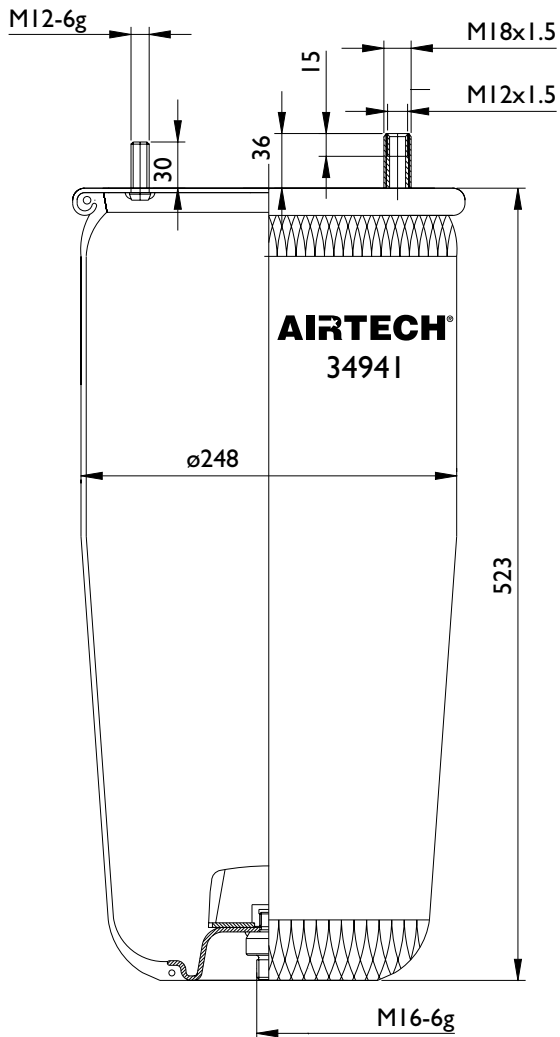

311046 Vista dall'alto

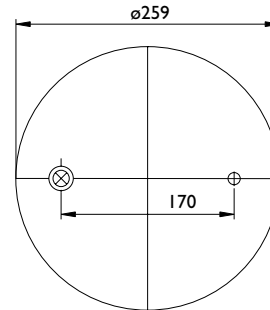

315003 Vista dal basso

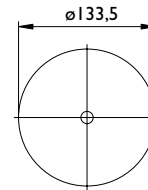

## Applicazioni principali

BPW	05.42941.250

## Lista corrispondenze

CONTITECH	4941 NP 02
FIRESTONE	
PHOENIX	
TAURUS	
DUNLOP UK	
DUNLOP F	
GOODYEAR	
PIRELLI	
GART	

⊗ Entrata aria

⊗ Perno combinato

# MOLLE AD ARIA COMPLETE



A520054C

**AIRTECH® 34941 K**

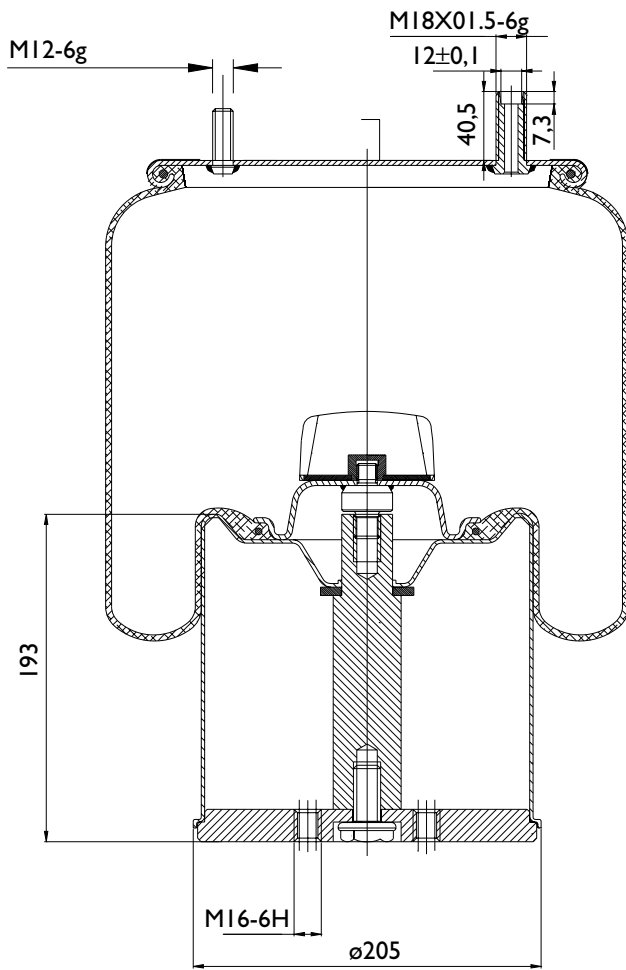

311046 Vista dall'alto

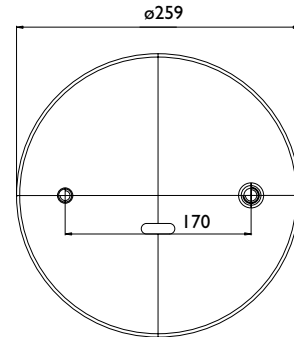

Vista dal basso

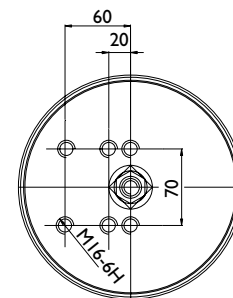

## Applicazioni principali

BPW	05.42941.250

## Lista corrispondenze

CONTITECH	4941 NP 02
FIRESTONE	
PHOENIX	
TAURUS	
DUNLOP UK	
DUNLOP F	
GOODYEAR	
PIRELLI	
GART	



Entrata aria



Perno combinato



A520047

**AIRTECH®** 34960

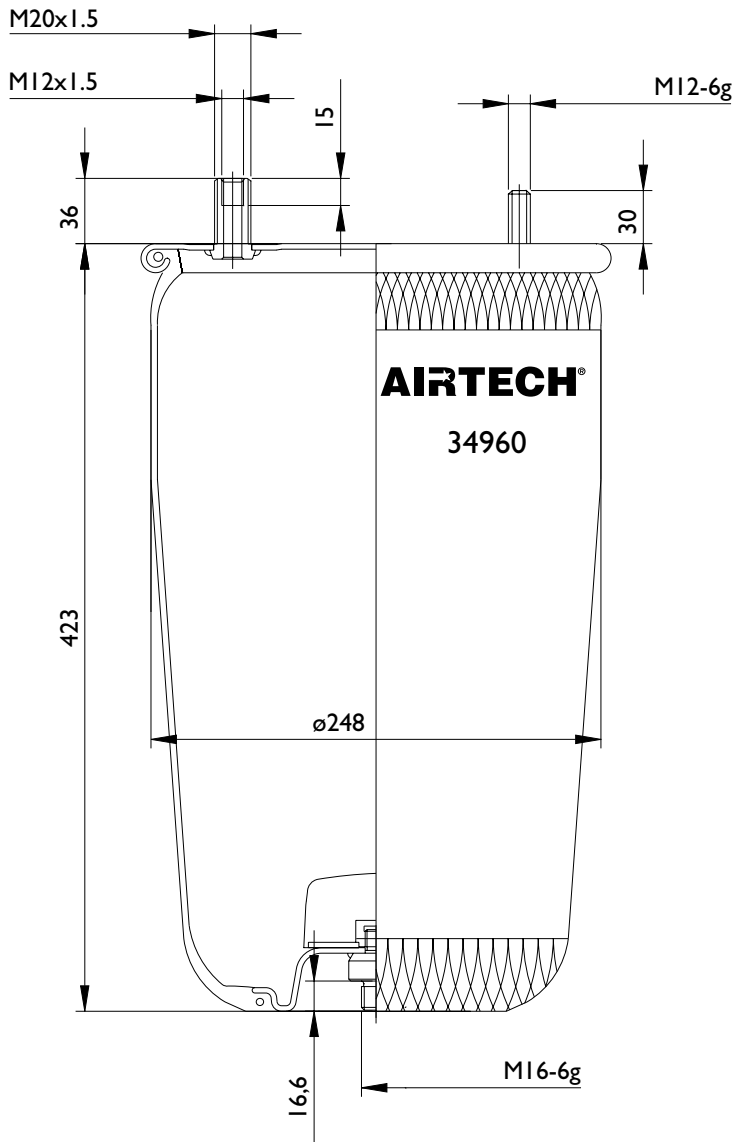

311016 Vista dall'alto

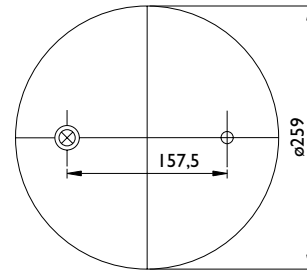

315003 Vista dal basso

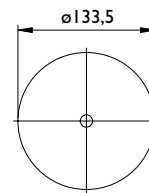

## Applicazioni principali

BPW	05.42941.770

## Lista corrispondenze

CONTITECH	4960 NP 02
FIRESTONE	
PHOENIX	
TAURUS	
DUNLOP UK	
DUNLOP F	
GOODYEAR	
PIRELLI	
GART	

⊗ Entrata aria

⊗ Perno combinato

# MOLLE AD ARIA SEMI-COMLETE



A520071

**AIRTECH® 34961**

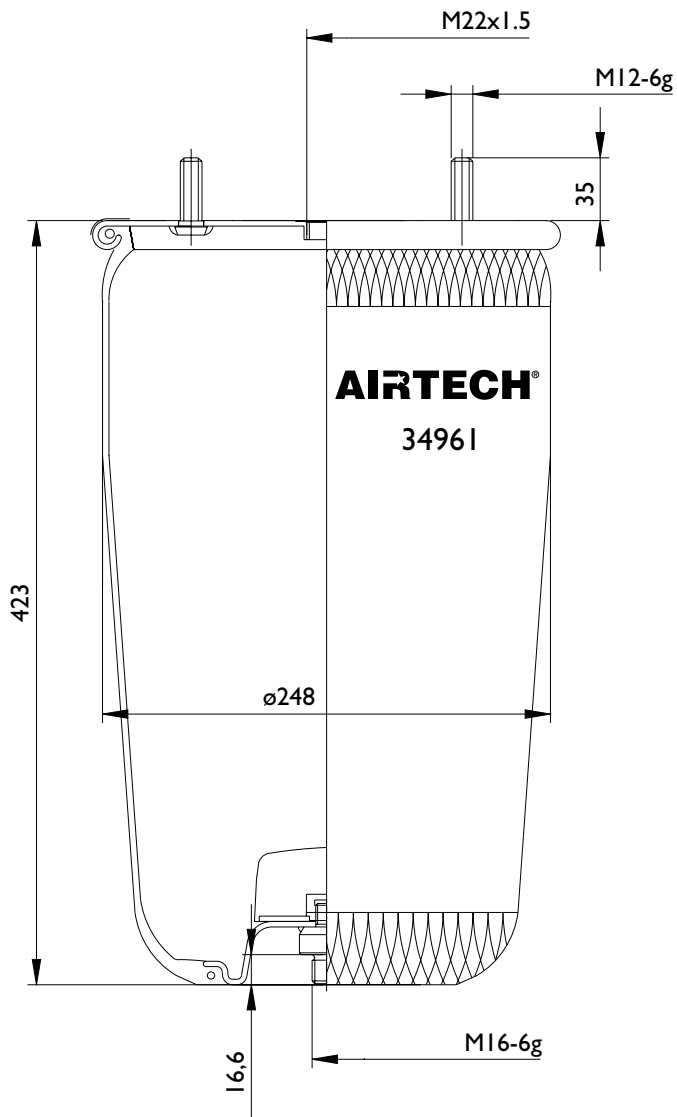

311035 Vista dall'alto

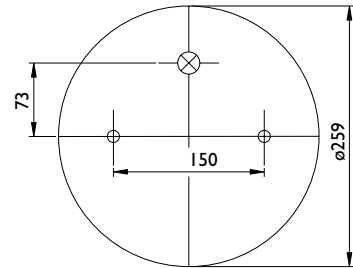

315003 Vista dal basso

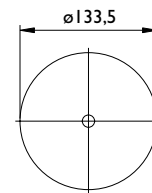

## Applicazioni principali

BPW	05.42942.040

## Lista corrispondenze

CONTITECH	4961 NP 02
FIRESTONE	
PHOENIX	
TAURUS	
DUNLOP UK	
DUNLOP F	
GOODYEAR	
PIRELLI	
GART	



Entrata aria



Perno combinato



**A520140C**

**AIRTECH® 36199 K**

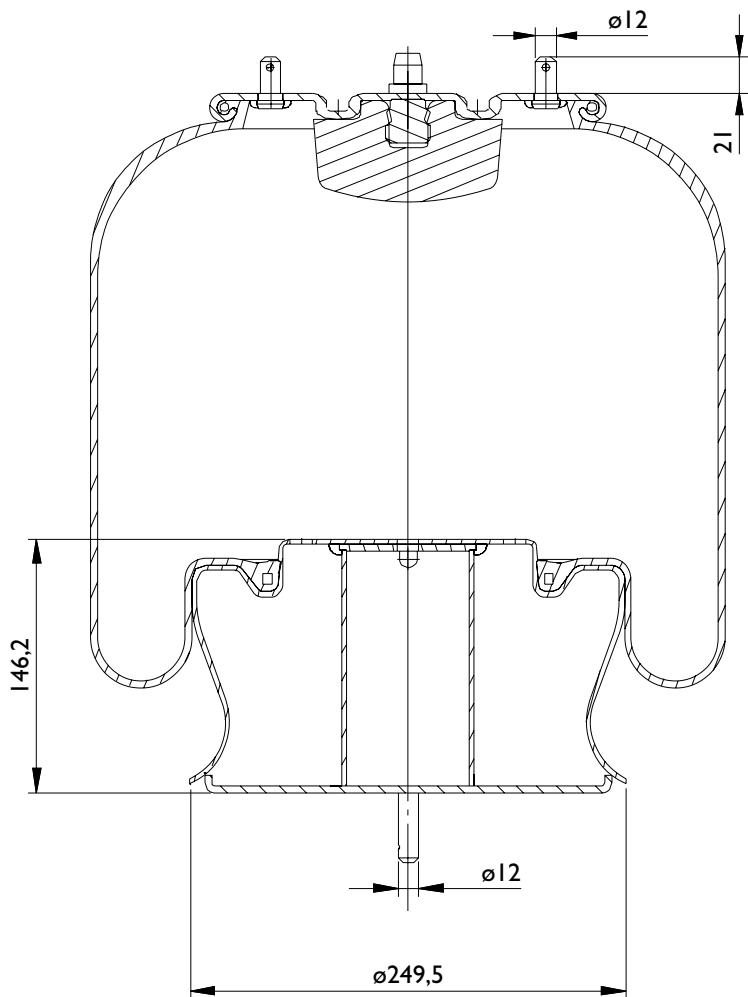

311153 Vista dall'alto

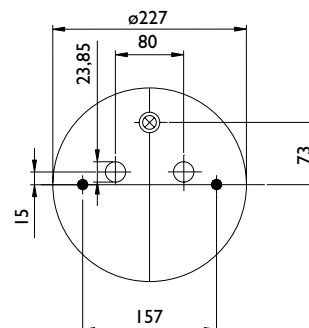

312083 Vista dal basso

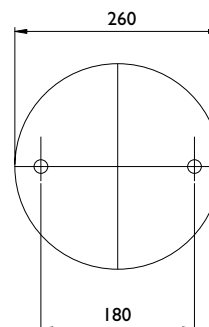

## Applicazioni principali

SCANIA SERIE 4 RIB.ANT.	1362145
SCANIA SERIE 4 RIB.ANT.	1370743
SCANIA SERIE 4 RIB.ANT.	1386199

## Lista corrispondenze

CONTITECH	
FIRESTONE	
PHOENIX	
TAURUS	
DUNLOP UK	
DUNLOP F	
GOODYEAR	
PIRELLI	
GART	

⊗ Entrata aria

⊗ Perno combinato



# MOLLE AD ARIA COMPLETE



A520139C

**AIRTECH® 36200 K**

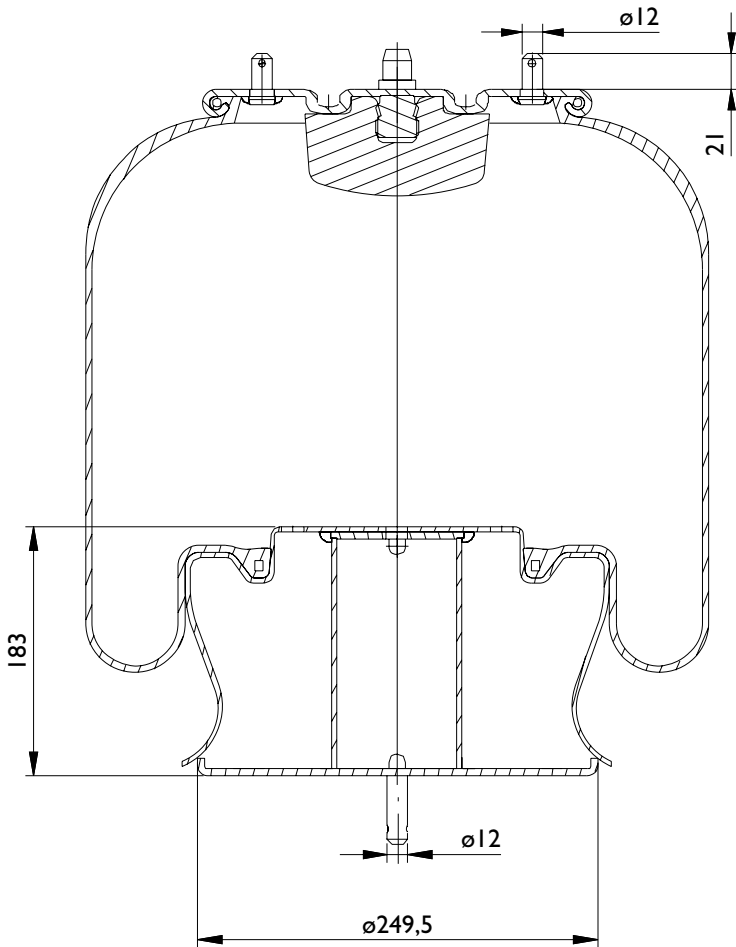

311153 Vista dall'alto

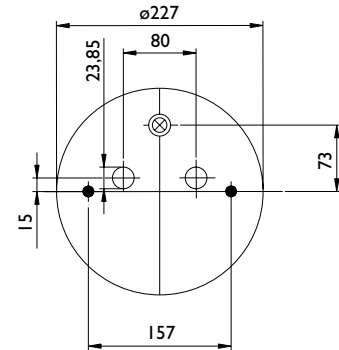

312082 Vista dal basso

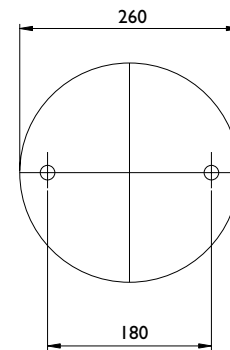

## Applicazioni principali

SCANIA SERIE 4 NOR.ANT.	I362147
SCANIA SERIE 4 NOR.ANT.	I370744
SCANIA SERIE 4 NOR.ANT.	I386200

## Lista corrispondenze

CONTITECH	
FIRESTONE	
PHOENIX	
TAURUS	
DUNLOP UK	
DUNLOP F	
GOODYEAR	
PIRELLI	
GART	

⊗ Entrata aria

⊗ Perno combinato



**A520175C**

**AIRTECH® 36416 K**

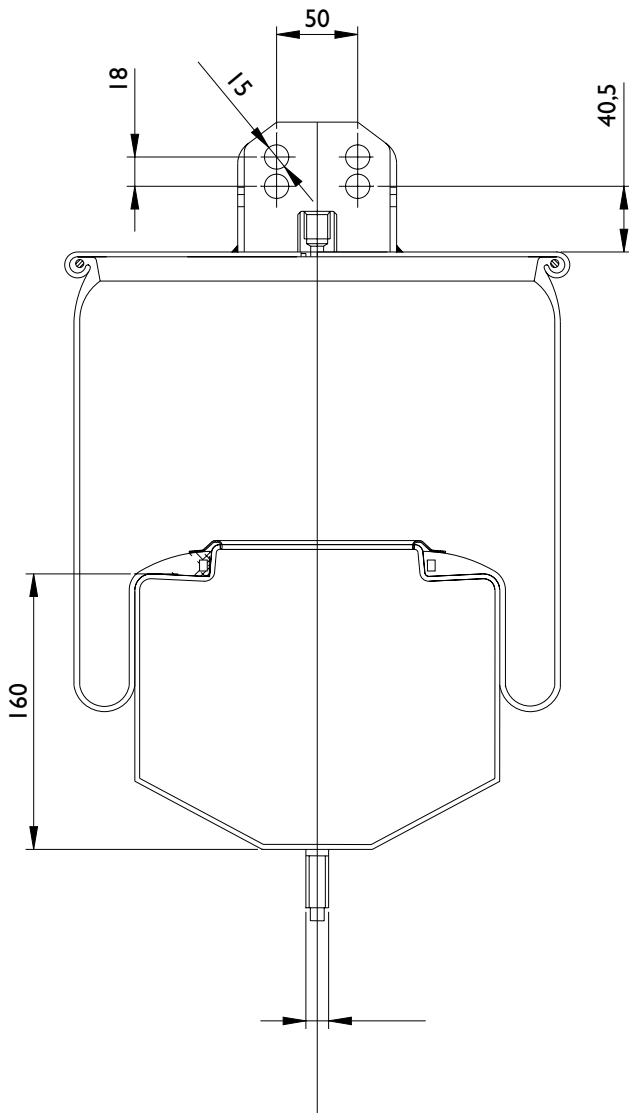

311069 Vista dall'alto

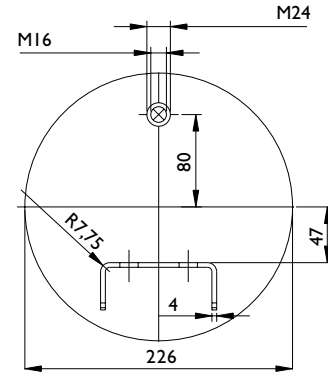

312084 Vista dal basso

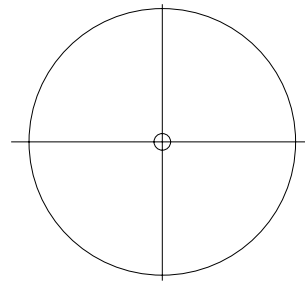

### Applicazioni principali

VOLVO	1076416
VOLVO	20456152

### Lista corrispondenze

CONTITECH	
FIRESTONE	
PHOENIX	
TAURUS	
DUNLOP UK	
DUNLOP F	
GOODYEAR	
PIRELLI	
GART	

⊗ Entrata aria

⊗ Perno combinato

# MOLLE AD ARIA COMPLETE



A520162C

AIRTECH® 36884 K

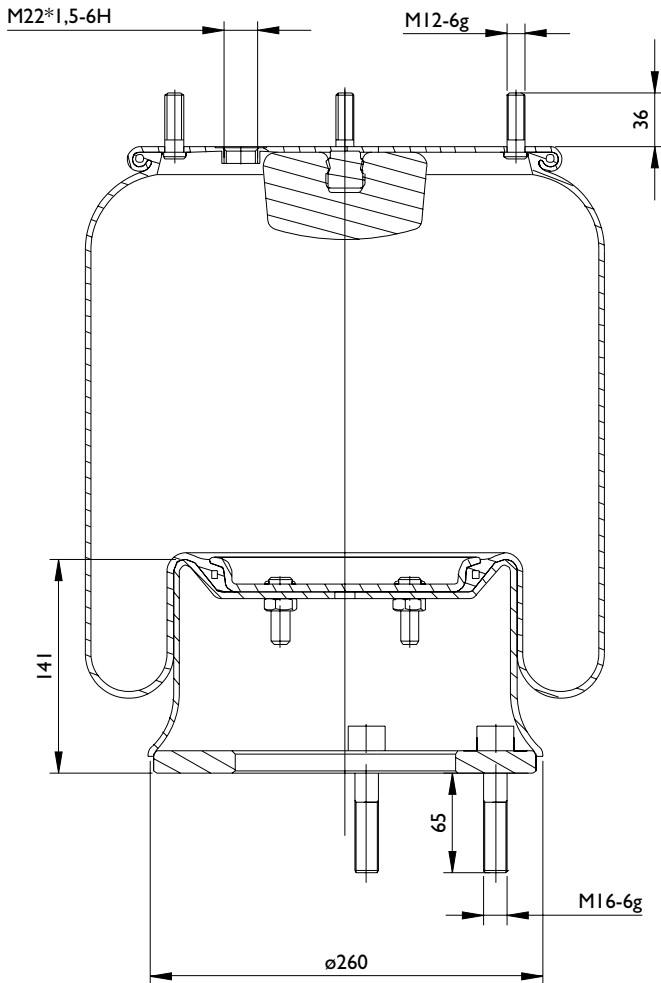

311003 Vista dall'alto

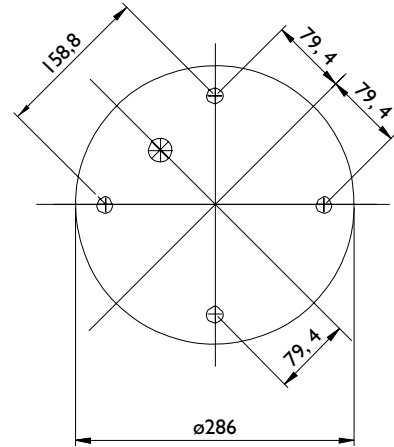

312108 Vista dal basso

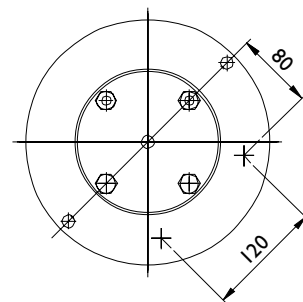

## Applicazioni principali

BERTOJA	46311001
ZORZI	1006546

## Lista corrispondenze

CONTITECH	
FIRESTONE	
PHOENIX	
TAURUS	
DUNLOP UK	
DUNLOP F	
GOODYEAR	
PIRELLI	IT 19 E-I 96884
GART	D277B 277.2.421



Entrata aria



Perno combinato



**A520163C**

**AIRTECH® 36885 K**

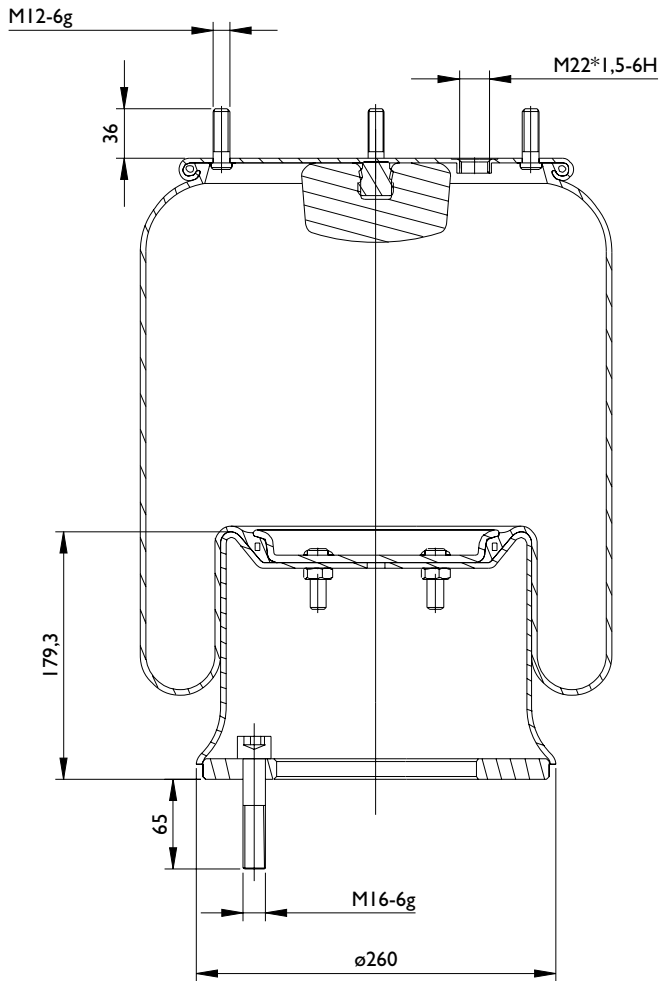

311003 Vista dall'alto

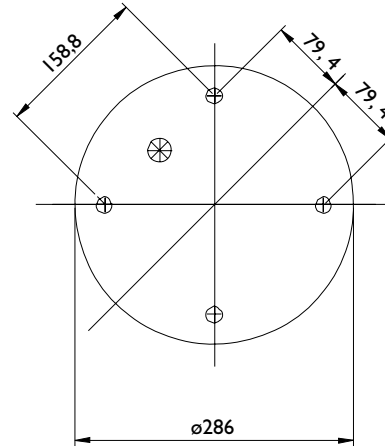

312107 Vista dal basso

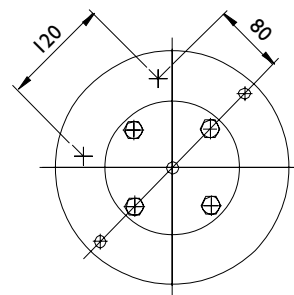

## Applicazioni principali

ZORZI	I006545

## Lista corrispondenze

CONTITECH	
FIRESTONE	
PHOENIX	
TAURUS	
DUNLOP UK	
DUNLOP F	
GOODYEAR	
PIRELLI	IT 19 E-2 96885
GART	D277 277.2.503

⊗ Entrata aria

⊗ Perno combinato

# MOLLE AD ARIA SEMI-COMLETE



## AIRTECH® 37803 P

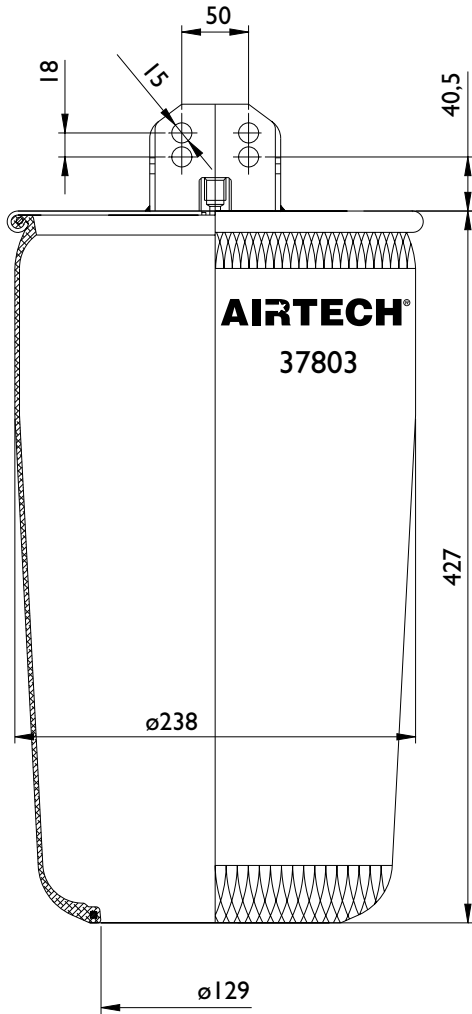

311069 Vista dall'alto

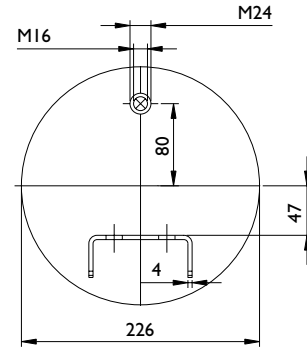

### Applicazioni principali

VOLVO	20427803

### Lista corrispondenze

CONTITECH	
FIRESTONE	
PHOENIX	
TAURUS	
DUNLOP UK	
DUNLOP F	
GOODYEAR	
PIRELLI	
GART	

⊗ Entrata aria

⊗ Perno combinato



**A520165C**

**AIRTECH® 38186 KPP**

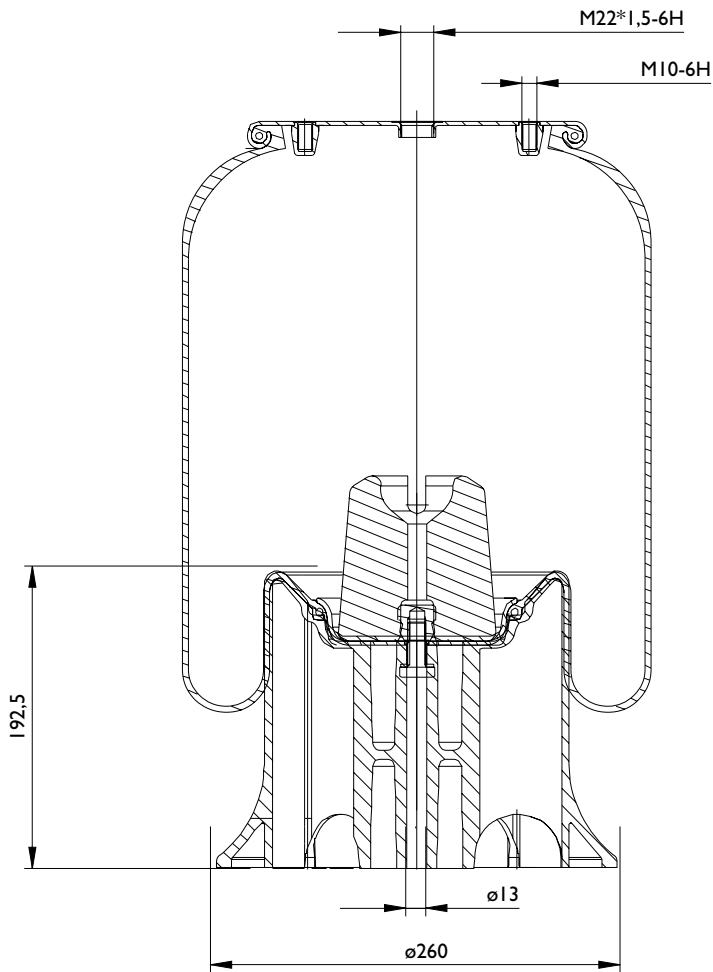

311112 Vista dall'alto

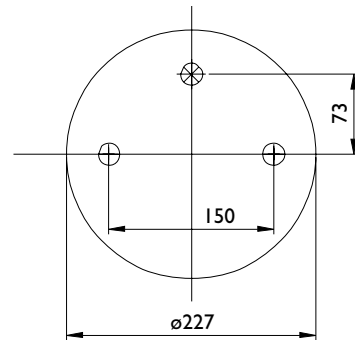

402014 Vista dal basso

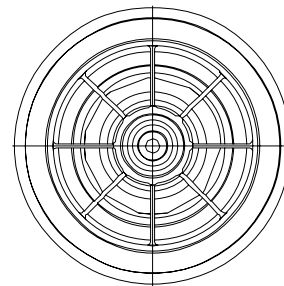

## Applicazioni principali

SCHMITZ	751065
WEWELER	USD6316F

## Lista corrispondenze

CONTITECH	4157NP06
FIRESTONE	IT 15 MPW 7W01 968 8186
PHOENIX	IDK20A1
TAURUS	
DUNLOP UK	
DUNLOP F	
GOODYEAR	IR11-764
PIRELLI	
GART	

⊗ Entrata aria

⊗ Perno combinato

# MOLLE AD ARIA SEMI-COMLETE



## AIRTECH® 39001

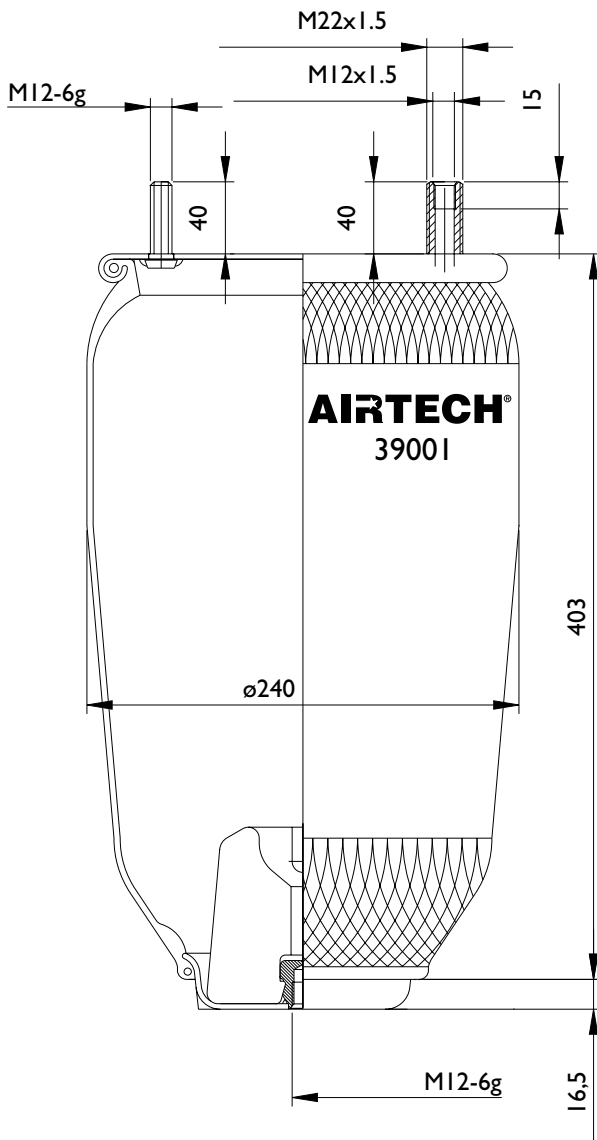

311033 Vista dall'alto

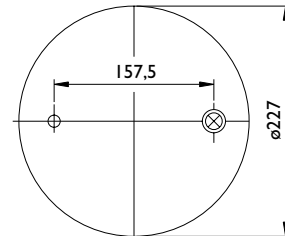

315001 Vista dal basso

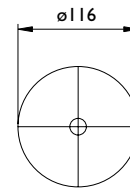

### Applicazioni principali

### Lista corrispondenze

CONTITECH	
FIRESTONE	
PHOENIX	
TAURUS	
DUNLOP UK	
DUNLOP F	
GOODYEAR	
PIRELLI	
GART	

⊗ Entrata aria

⊗ Perno combinato

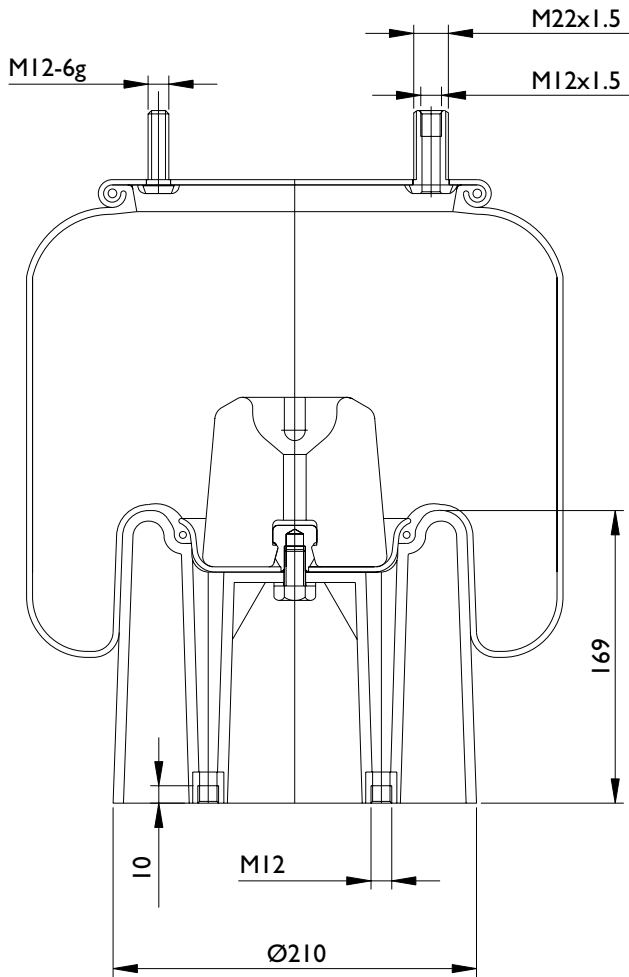
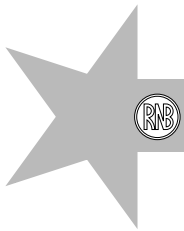

311033 Vista dall'alto

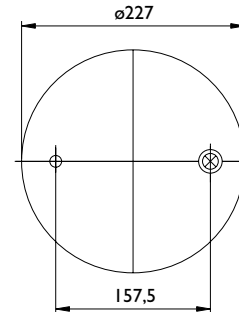

402001 Vista dal basso

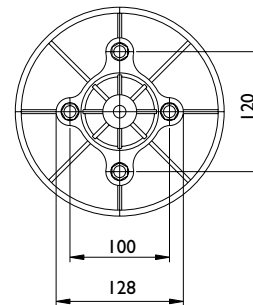

### Applicazioni principali

### Lista corrispondenze

CONTITECH	
FIRESTONE	
PHOENIX	
TAURUS	
DUNLOP UK	
DUNLOP F	
GOODYEAR	
PIRELLI	
GART	

⊗ Entrata aria

⊙ Perno combinato



# MOLLE AD ARIA SEMI-COMLETE



## AIRTECH® 39002-A3

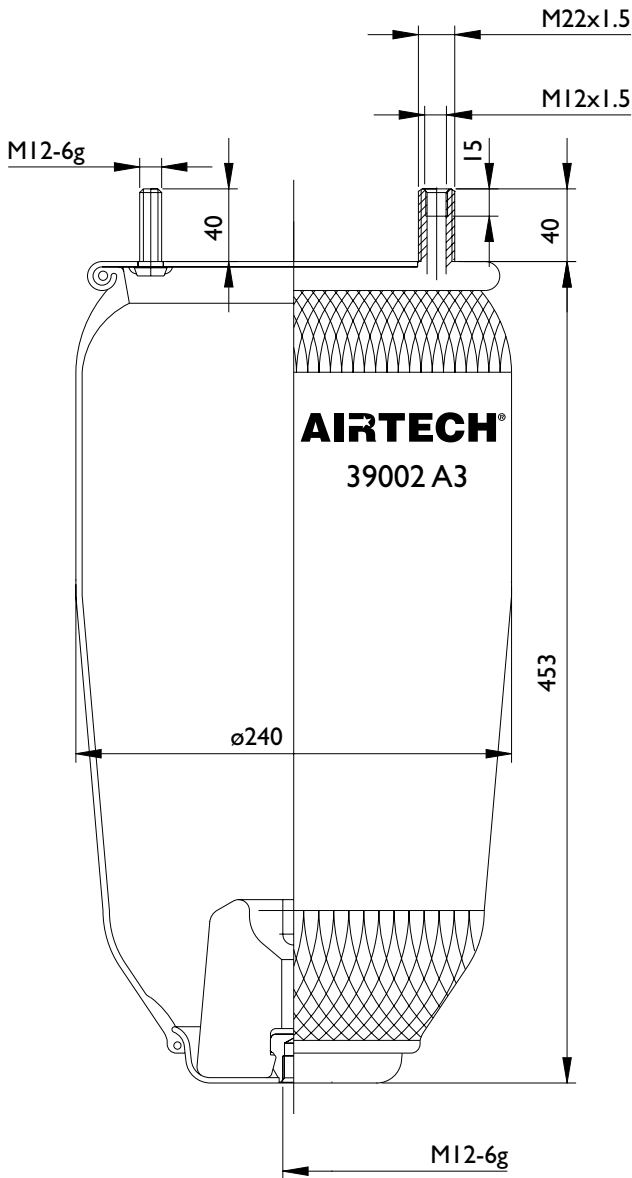

311033 Vista dall'alto

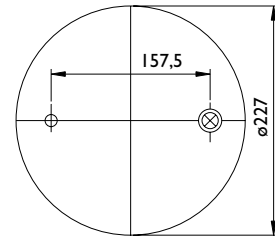

315001 Vista dal basso

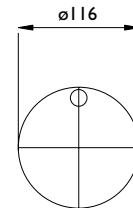

### Applicazioni principali

ROR	21222442

### Lista corrispondenze

CONTITECH	4157 NP 05
FIRESTONE	I T 15 MPW-7 / W01 M58 7074
PHOENIX	IDK 21A3
TAURUS	
DUNLOP UK	
DUNLOP F	D12 B17
GOODYEAR	IR11-106
PIRELLI	ITC300-38
GART	

⊗ Entrata aria

⊗ Perno combinato



**A520036C**

**AIRTECH® 39002-A3 K**

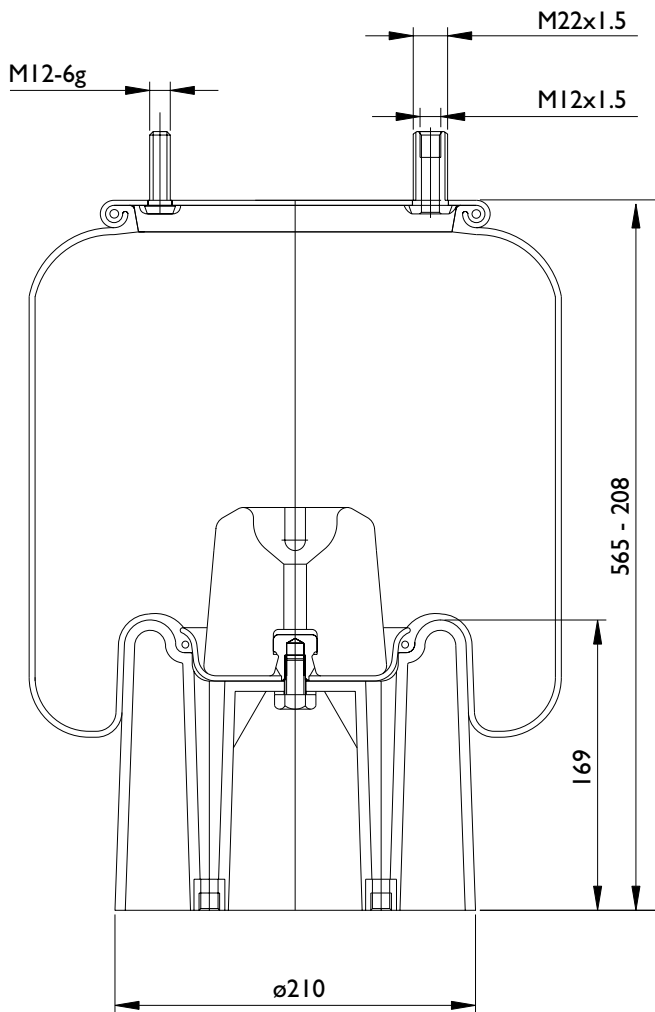

311033 Vista dall'alto

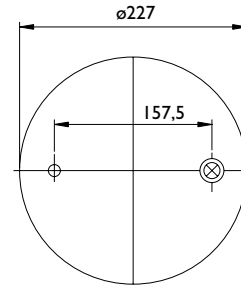

402001 Vista dal basso

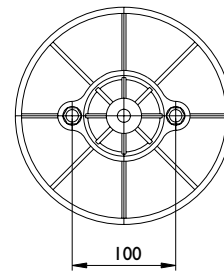

## Applicazioni principali

ROR / MERITOR	21222442
WEWELER	US07074

## Lista corrispondenze

CONTITECH	4157NP05
FIRESTONE	1T-15 MPW7/W01 M58 7074
PHOENIX	1 DK 21 A-3
TAURUS	KR915-54
DUNLOP UK	
DUNLOP F	D12 B17
GOODYEAR	1R11-106
PIRELLI	ITC300-38 / 205598
GART	C294 294.2.450

⊗ Entrata aria

⊗ Perno combinato

# MOLLE AD ARIA COMPLETE



A520127C

**AIRTECH®** 39002-A3-01 K

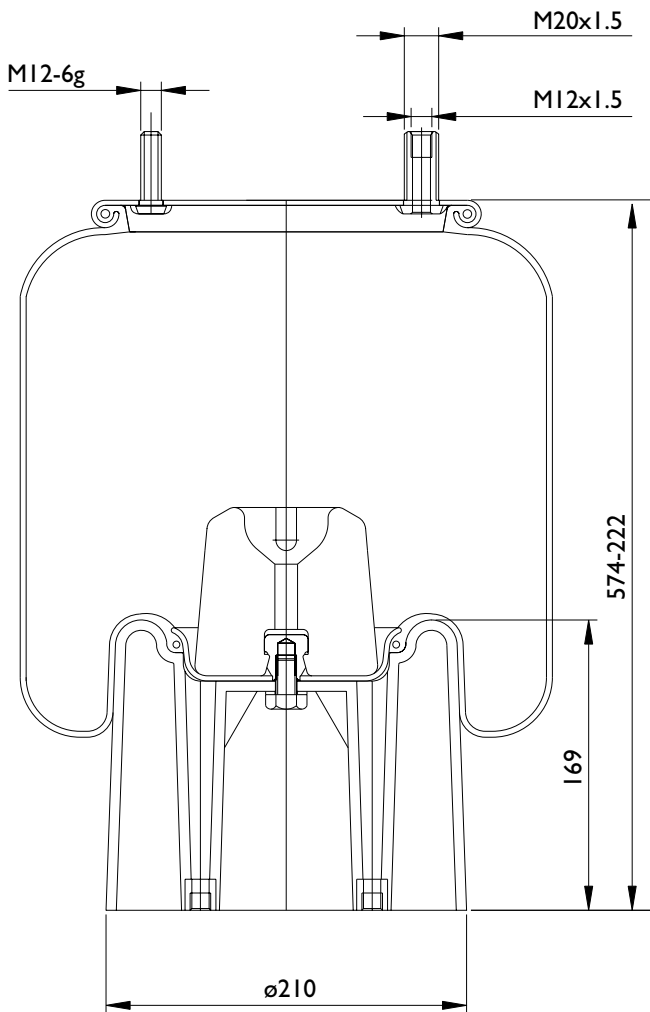

311033 Vista dall'alto

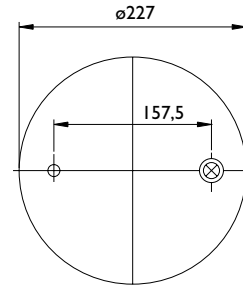

Vista dal basso

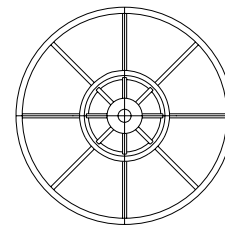

## Applicazioni principali

FRUEHAUF	UJB0975
SMB	M060924

## Lista corrispondenze

CONTITECH	
FIRESTONE	IT-15 MPW7/W01 379 6315
PHOENIX	
TAURUS	KR 915-51
DUNLOP UK	
DUNLOP F	
GOODYEAR	
PIRELLI	
GART	

⊗ Entrata aria

⊗ Perno combinato

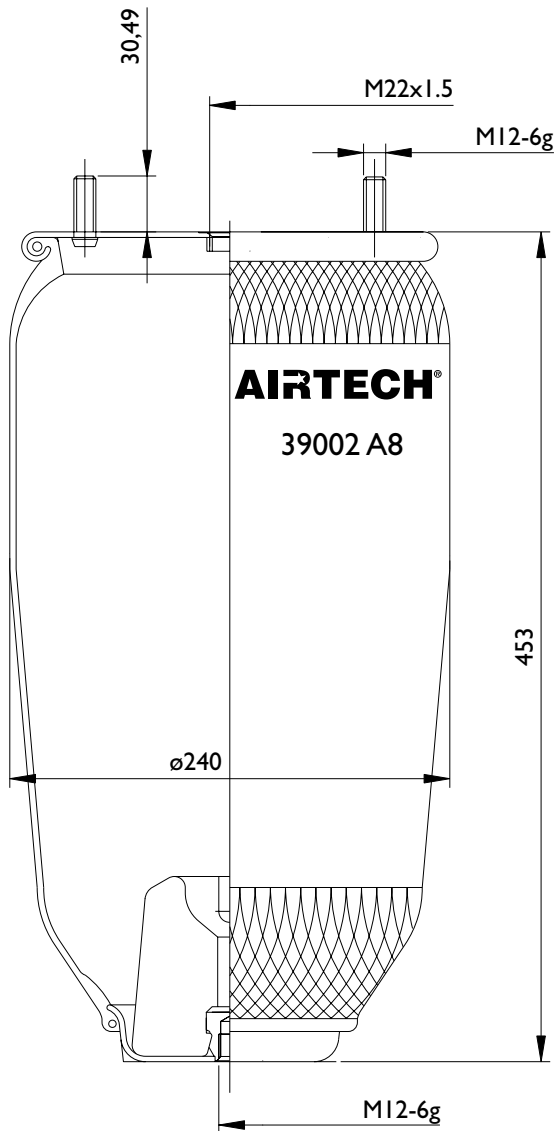

311028 Vista dall'alto

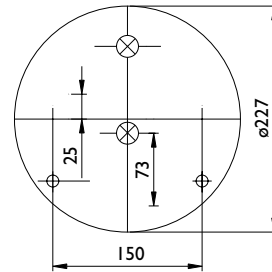

315001 Vista dal basso

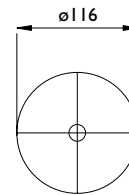

### Applicazioni principali

ROR	21221307

### Lista corrispondenze

CONTITECH	4157 NP 04
FIRESTONE	1 T 15 MPW-7 / W01 M58 6297
PHOENIX	IDK 21A8
TAURUS	
DUNLOP UK	
DUNLOP F	D12-B18
GOODYEAR	IR11-111
PIRELLI	
GART	

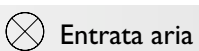

Entrata aria



Perno combinato

# MOLLE AD ARIA COMPLETE



A520037C

AIRTECH® 39002-A8 KPP

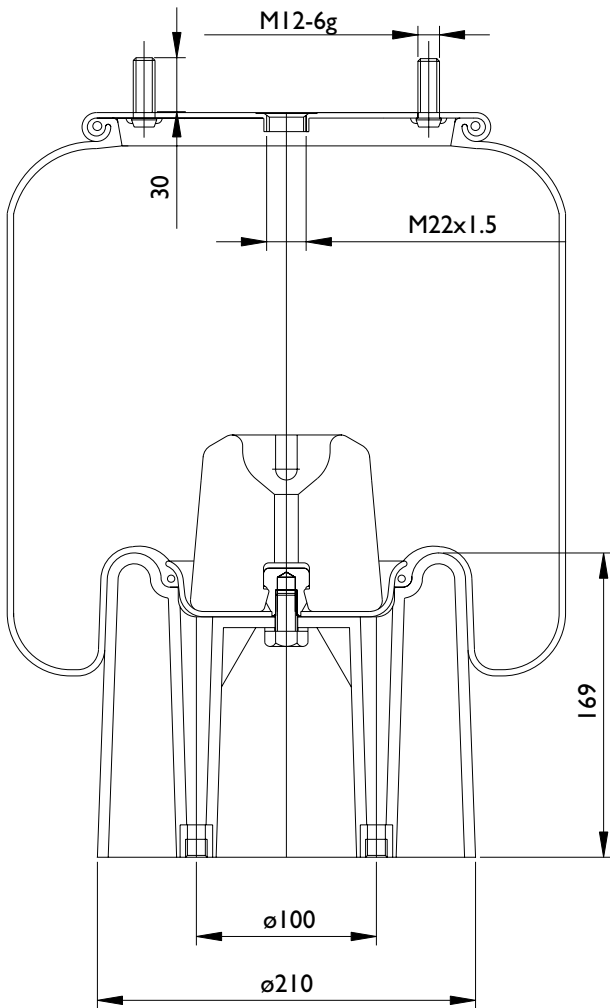

311028 Vista dall'alto

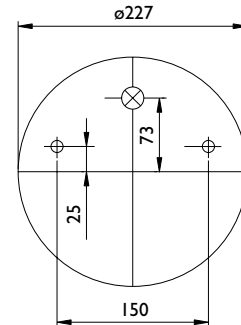

402001 Vista dal basso

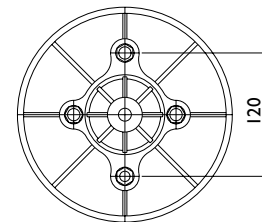

## Applicazioni principali

ROR	21221307

## Lista corrispondenze

CONTITECH	4158NP04
FIRESTONE	I T 15 MPW7 / W01 M58 6297
PHOENIX	I DK 21 A-8 / 4
TAURUS	
DUNLOP UK	
DUNLOP F	D12 B18
GOODYEAR	
PIRELLI	I T 300-40
GART	C294 294.2.451



Entrata aria



Perno combinato

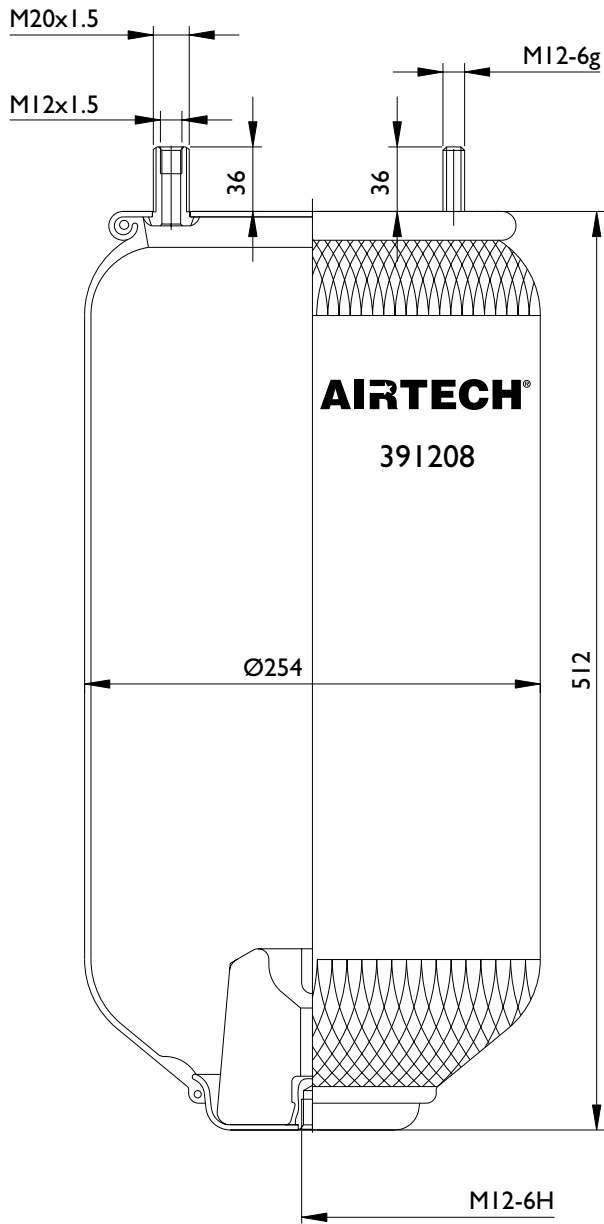
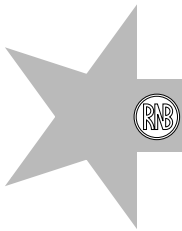

311026 Vista dall'alto

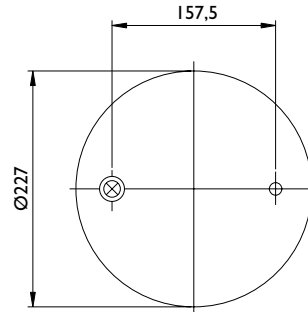

315001 Vista dal basso

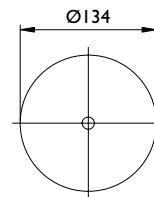

### Applicazioni principali

### Lista corrispondenze

CONTITECH	
FIRESTONE	
PHOENIX	
TAURUS	
DUNLOP UK	
DUNLOP F	
GOODYEAR	
PIRELLI	
GART	

⊗ Entrata aria

⊗ Perno combinato

# MOLLE AD ARIA COMPLETE



A520172C

**AIRTECH® 39780 K**

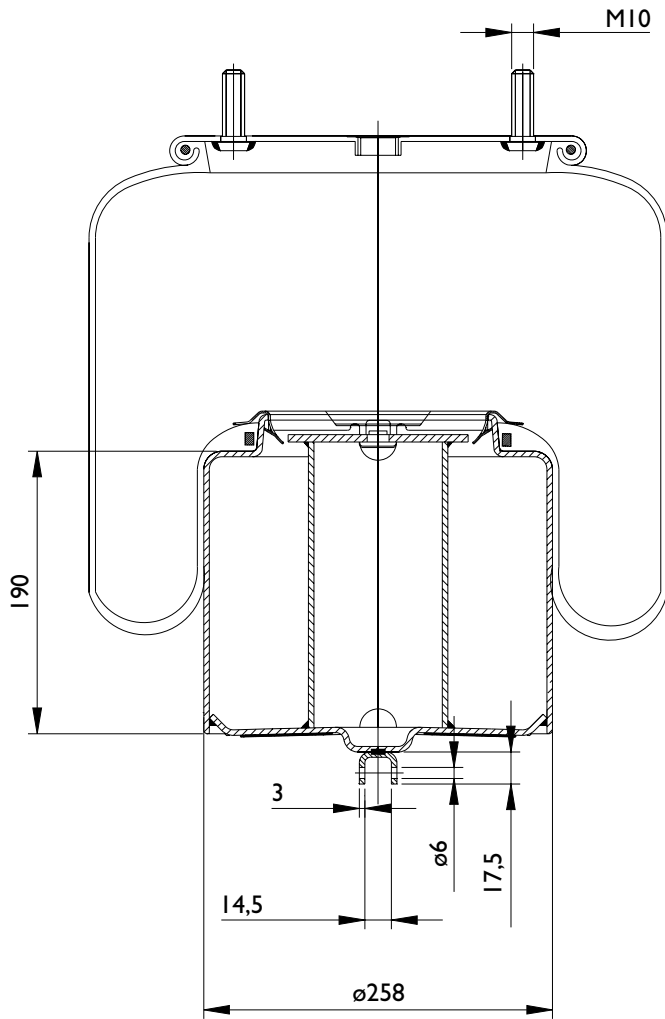

311115 Vista dall'alto

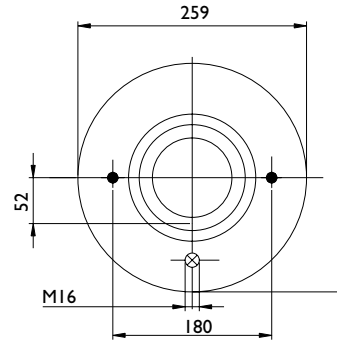

312074 Vista dal basso

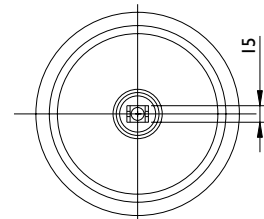

## Applicazioni principali

VOLVO FM7/10/12 - FH12/16	107 53 64
VOLVO FM7/10/12 - FH12/16	162 97 80

## Lista corrispondenze

CONTITECH	
FIRESTONE	
PHOENIX	
TAURUS	
DUNLOP UK	
DUNLOP F	
GOODYEAR	
PIRELLI	
GART	

⊗ Entrata aria

⊗ Perno combinato



**A520149C**

**AIRTECH® 361420 K**

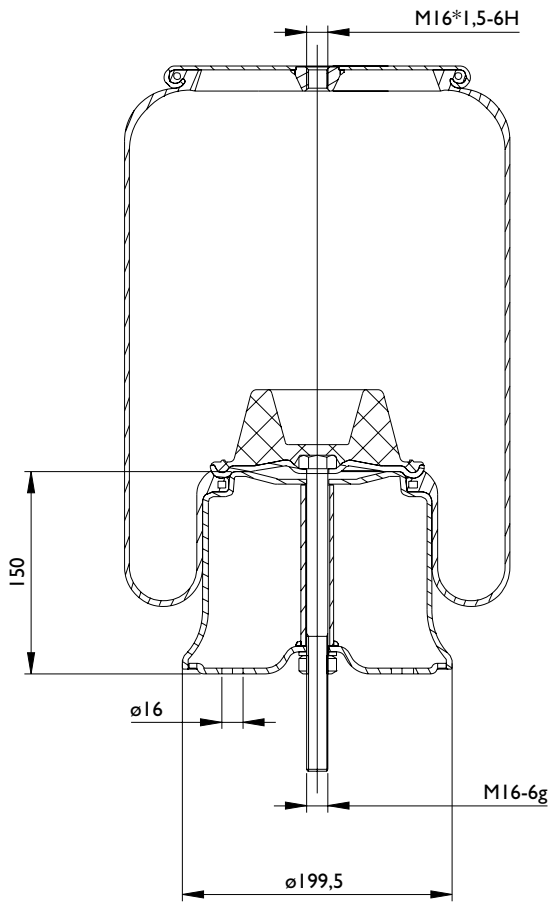

311214 Vista dall'alto

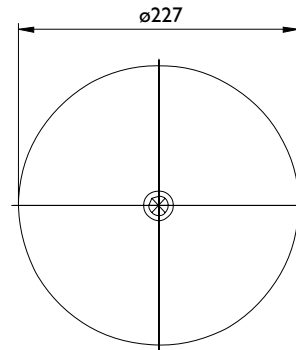

312102 Vista dal basso

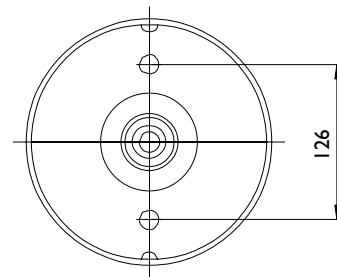

## Applicazioni principali

AUSTERAS	99381009

## Lista corrispondenze

CONTITECH	
FIRESTONE	
PHOENIX	
TAURUS	
DUNLOP UK	
DUNLOP F	
GOODYEAR	
PIRELLI	
GART	D 276/R 276.1.420

⊗ Entrata aria

⊗ Perno combinato



# MOLLE AD ARIA COMPLETE



A520144C

AIRTECH® 361421 K

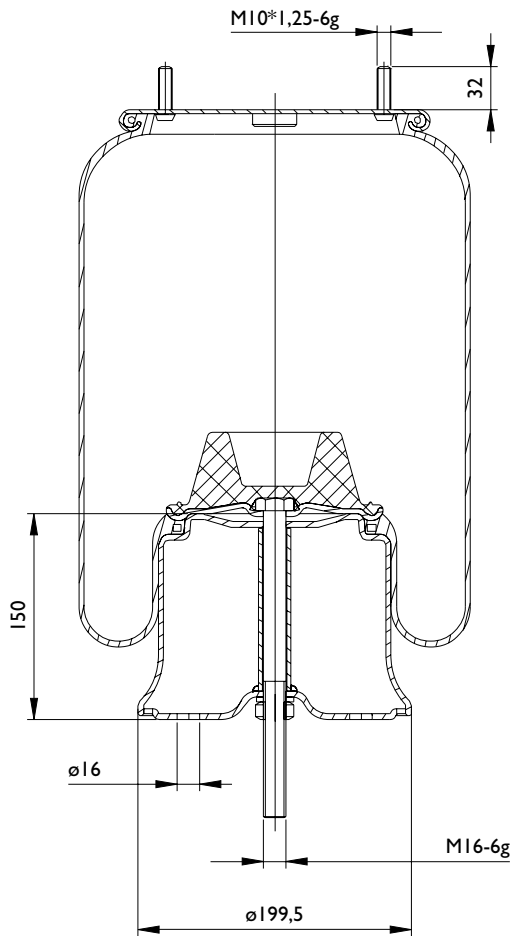

311105 Vista dall'alto

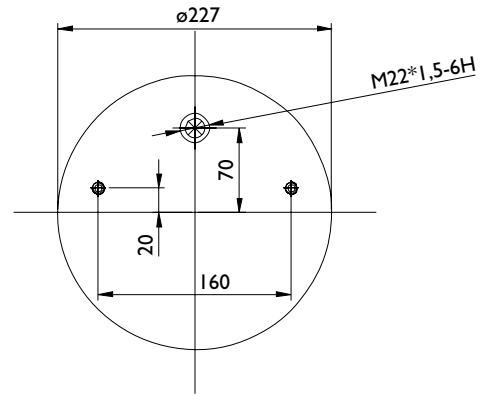

312102 Vista dal basso

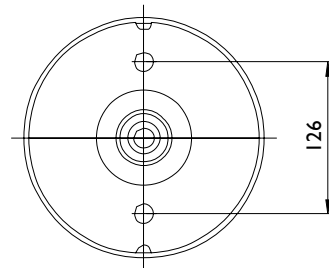

## Applicazioni principali

BATTAGLINO	2211907
CAMPANA	05040200
TRAS CAR	3003000070

## Lista corrispondenze

CONTITECH	
FIRESTONE	
PHOENIX	
TAURUS	
DUNLOP UK	
DUNLOP F	
GOODYEAR	
PIRELLI	
GART	D 276/R 276.1.421



Entrata aria



Perno combinato



**A520148C**

**AIRTECH® 361480 K**

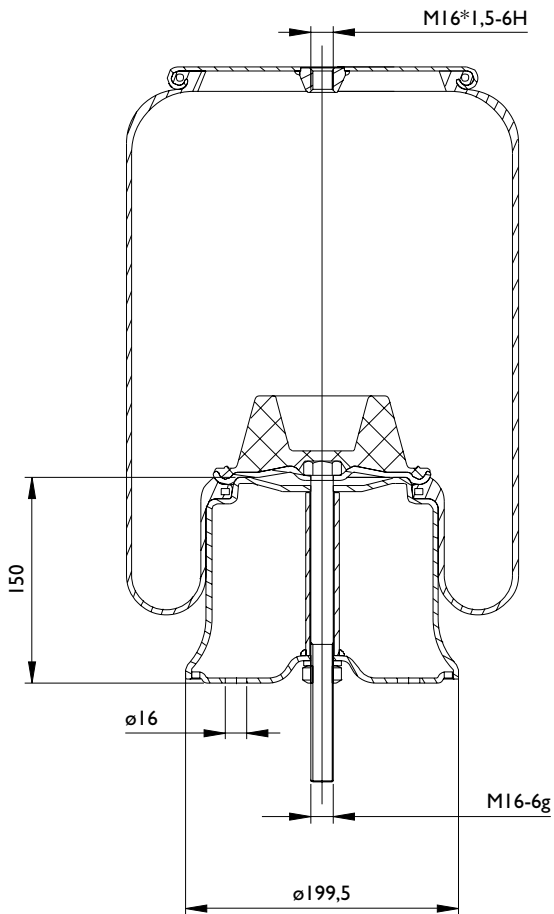

311214 Vista dall'alto

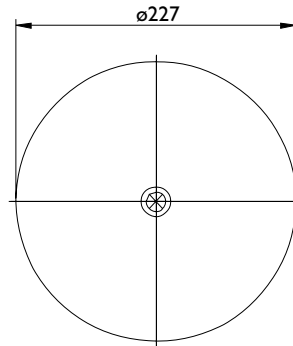

312102 Vista dal basso

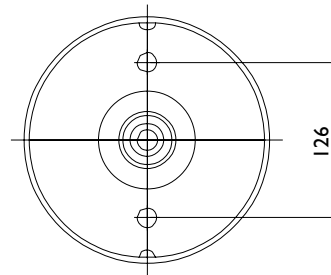

## Applicazioni principali

AUSTERAS	99381010

## Lista corrispondenze

CONTITECH	
FIRESTONE	
PHOENIX	
TAURUS	
DUNLOP UK	
DUNLOP F	
GOODYEAR	
PIRELLI	
GART	D 276/LR 276.1.480

⊗ Entrata aria

⊗ Perno combinato

# MOLLE AD ARIA COMPLETE



A520145C

AIRTECH® 361481 K

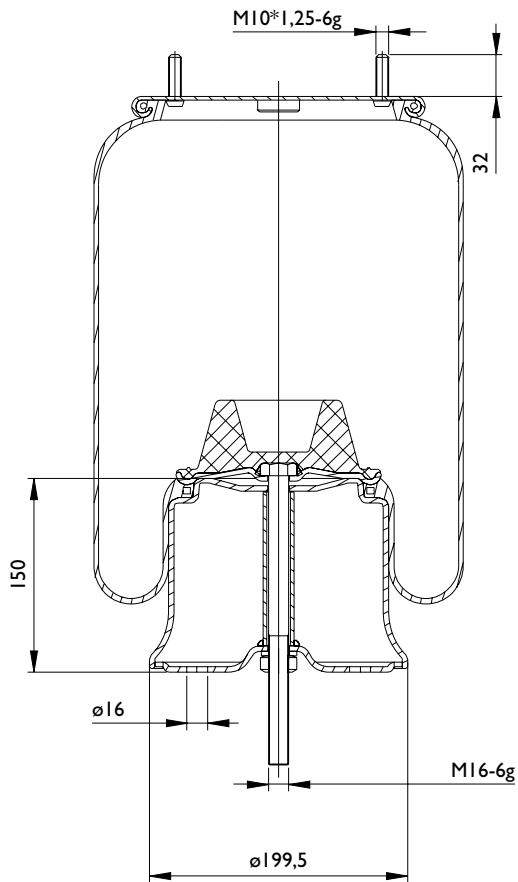

311105 Vista dall'alto

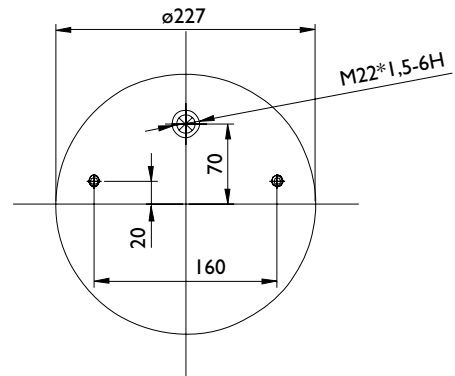

312102 Vista dal basso

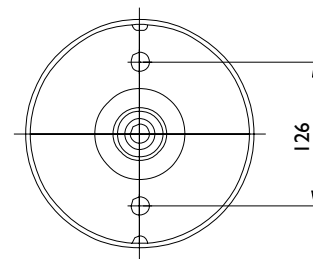

## Applicazioni principali

TRAS CAR	3003000060

## Lista corrispondenze

CONTITECH	
FIRESTONE	
PHOENIX	
TAURUS	
DUNLOP UK	
DUNLOP F	
GOODYEAR	
PIRELLI	
GART	D 276/LR 276.1.481



Entrata aria



Perno combinato



**A520167C**

**AIRTECH® 362421 K**

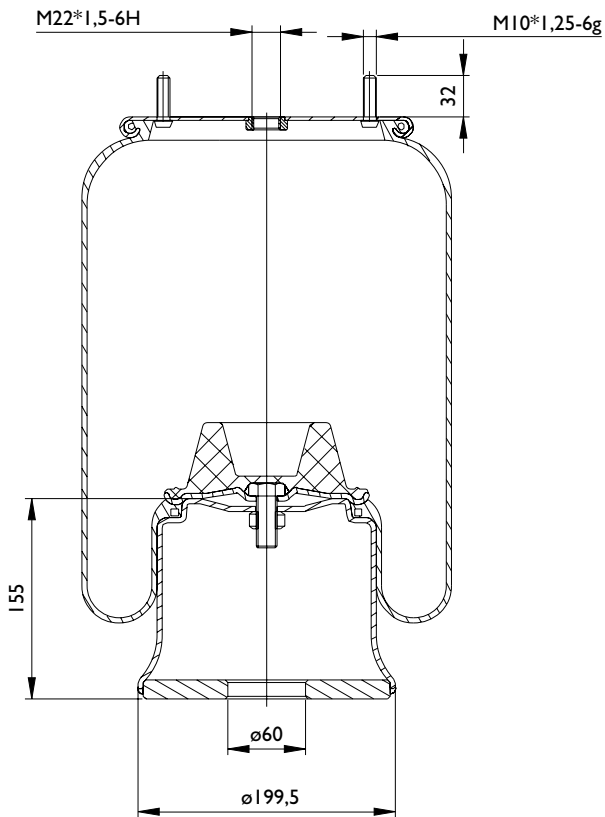

311105 Vista dall'alto

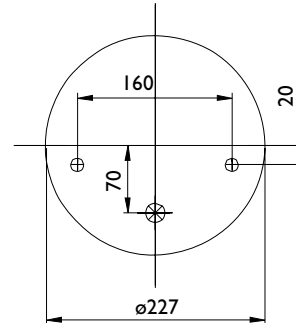

312103 Vista dal basso

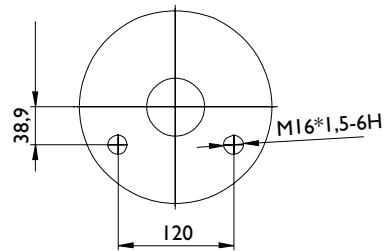

## Applicazioni principali

BATTAGLINO	2211900

## Lista corrispondenze

CONTITECH	
FIRESTONE	
PHOENIX	
TAURUS	
DUNLOP UK	
DUNLOP F	
GOODYEAR	
PIRELLI	
GART	D276/R-2 F 276.2.421

⊗ Entrata aria

⊗ Perno combinato

# MOLLE AD ARIA COMPLETE



A520166C

AIRTECH® 374521 K

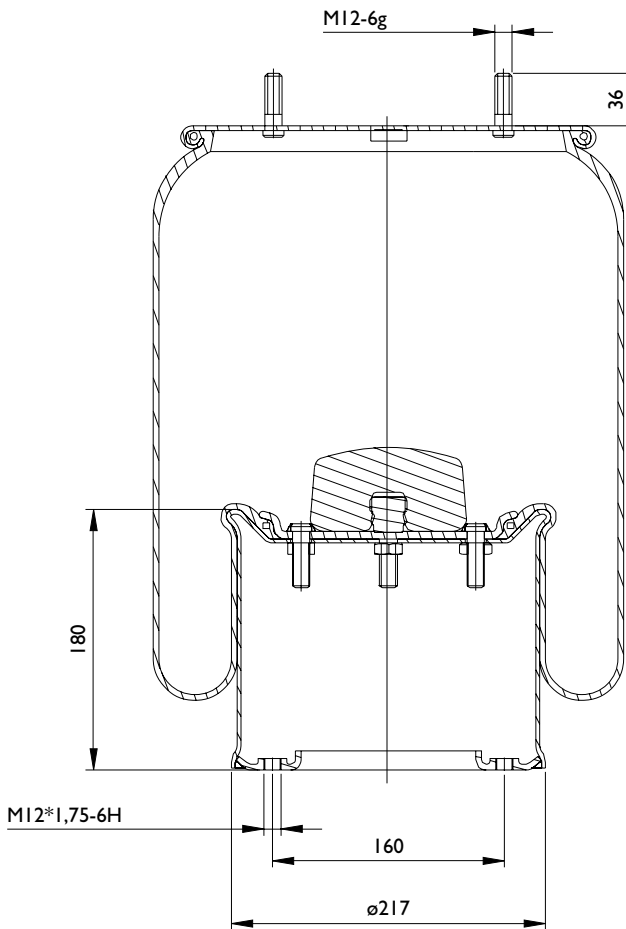

311004 Vista dall'alto

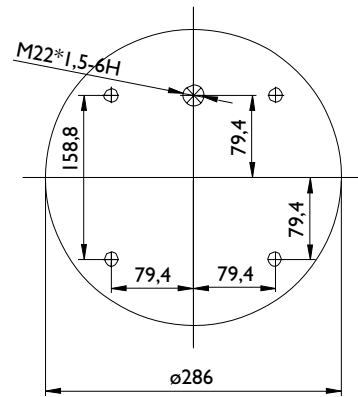

312105 Vista dal basso

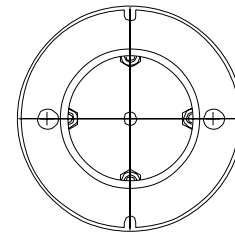

## Applicazioni principali

BPW	041030090

## Lista corrispondenze

CONTITECH	
FIRESTONE	
PHOENIX	
TAURUS	
DUNLOP UK	
DUNLOP F	
GOODYEAR	
PIRELLI	
GART	D 277/DA 277.4.251



Entrata aria



Perno combinato



**A520142C**

**AIRTECH® 382430 K**

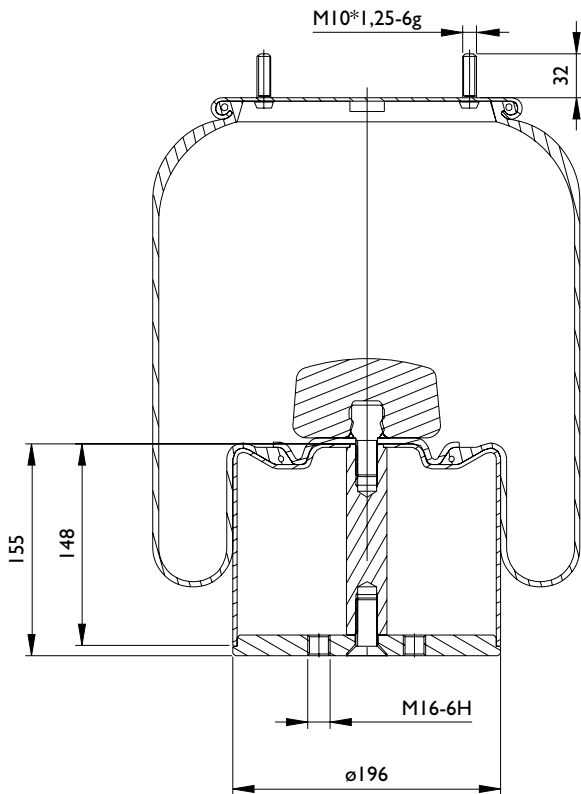

311211 Vista dall'alto

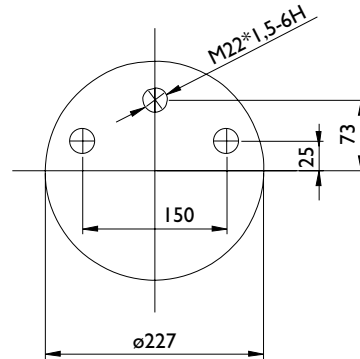

Vista dal basso

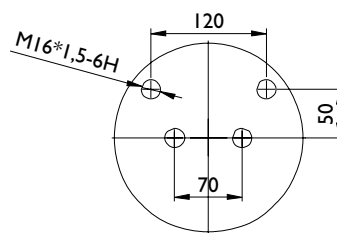

## Applicazioni principali

BATTAGLINO	041040010
CAMPANA	050400100

## Lista corrispondenze

CONTITECH	
FIRESTONE	
PHOENIX	
TAURUS	
DUNLOP UK	
DUNLOP F	
GOODYEAR	
PIRELLI	
GART	D 278/E 278.2.430

⊗ Entrata aria

⊗ Perno combinato

# MOLLE AD ARIA COMPLETE



A520143C

AIRTECH® 382520 K

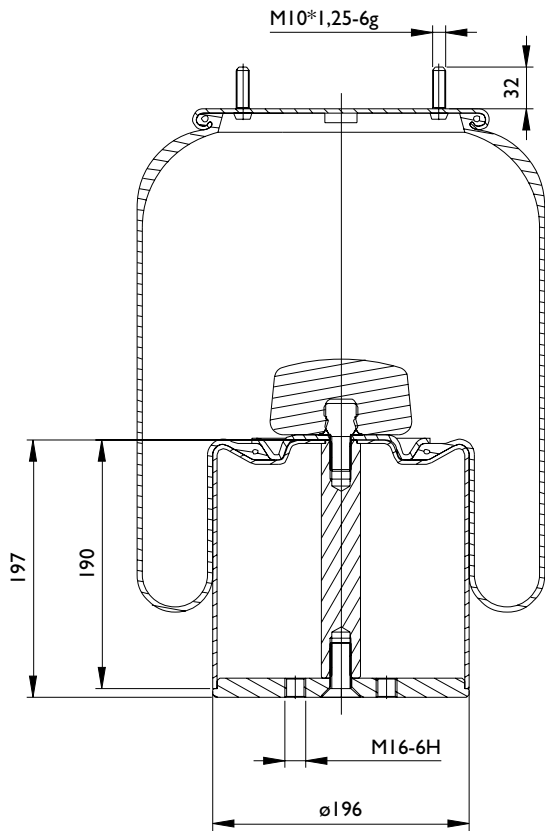

311211 Vista dall'alto

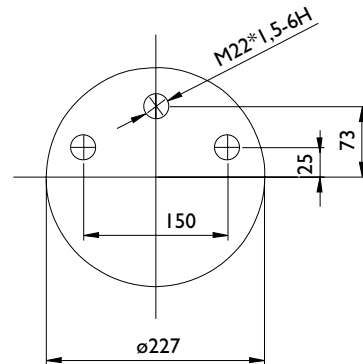

Vista dal basso

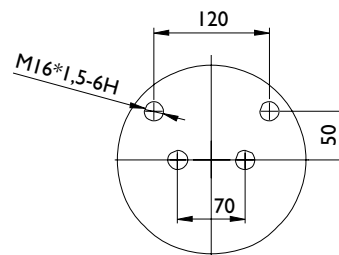

## Applicazioni principali

AUSTERAS	99381031

## Lista corrispondenze

CONTITECH	
FIRESTONE	
PHOENIX	
TAURUS	
DUNLOP UK	
DUNLOP F	
GOODYEAR	
PIRELLI	
GART	D 278/F 278.2.520

⊗ Entrata aria

⊗ Perno combinato



**A520024C**

**AIRTECH® 391208 K**

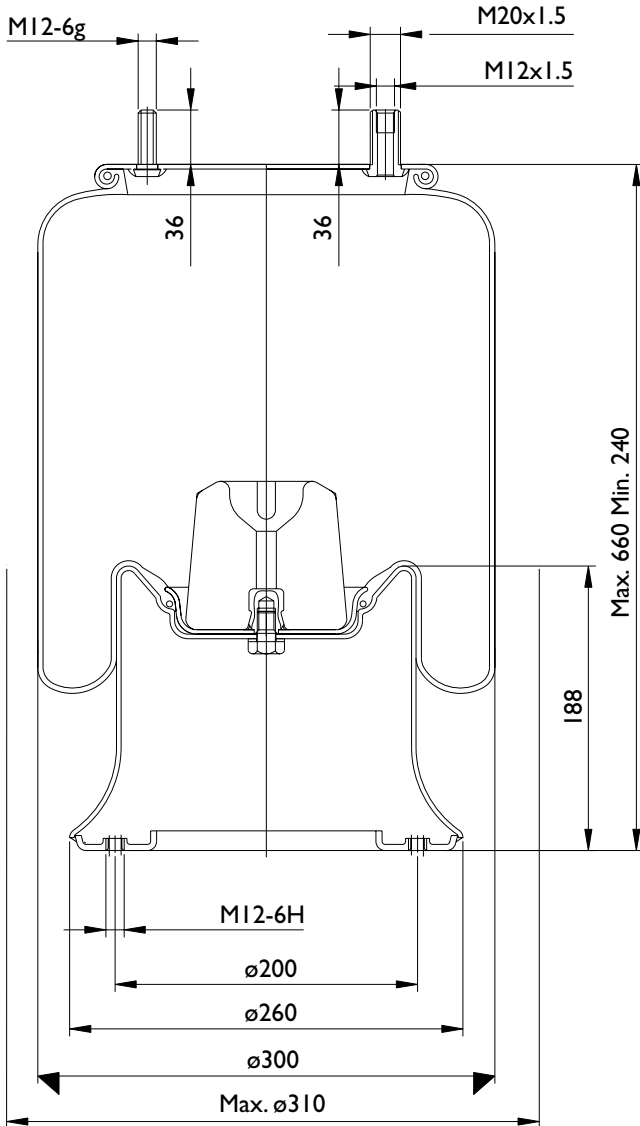

311026 Vista dall'alto

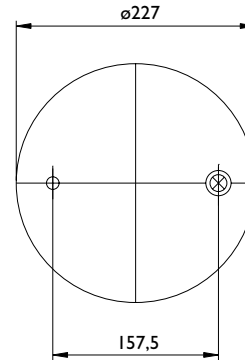

312010 Vista dal basso

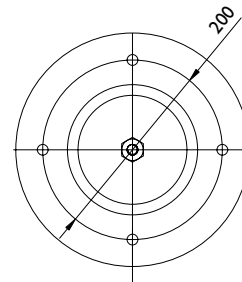

## Applicazioni principali

FRUEHAUF	M001782
FRUEHAUF	UJB0203
FRUEHAUF	UJA0894
SAMRO	2500425

## Lista corrispondenze

CONTITECH	
FIRESTONE	1T 15 M-9 /W01 M58 8859/379 9091
PHOENIX	
TAURUS	KR 509-9091
DUNLOP UK	
DUNLOP F	D 12 B 08/01
GOODYEAR	
PIRELLI	
GART	

⊗ Entrata aria

⊗ Perno combinato



# MOLLE AD ARIA COMPLETE



A520023C

AIRTECH® 391209 K

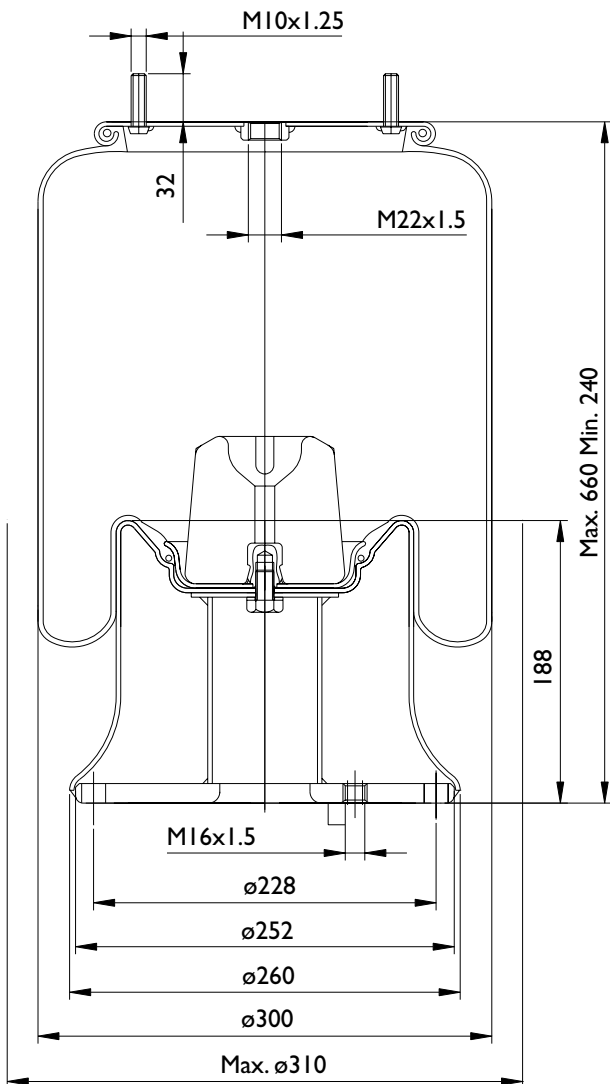

311105 Vista dall'alto

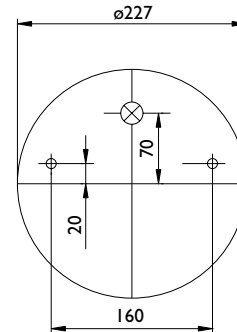

312026 Vista dal basso

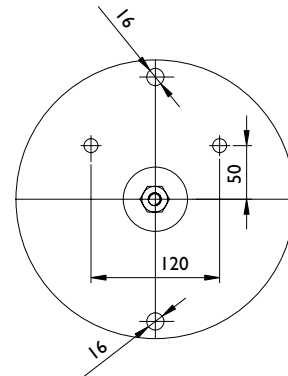

## Applicazioni principali

CARDI	58050900
OMAR	11808
ROLFO	112322
ZORZI	1006551

## Lista corrispondenze

CONTITECH	
FIRESTONE	I T 15 M-9 / W01 M58 6289
PHOENIX	
TAURUS	
DUNLOP UK	
DUNLOP F	D 12 B 07/09
GOODYEAR	
PIRELLI	I T 323-40 / 96871
GART	D278H 278.2.512



Entrata aria



Perno combinato



**A520006C**

**AIRTECH® 391210 K**

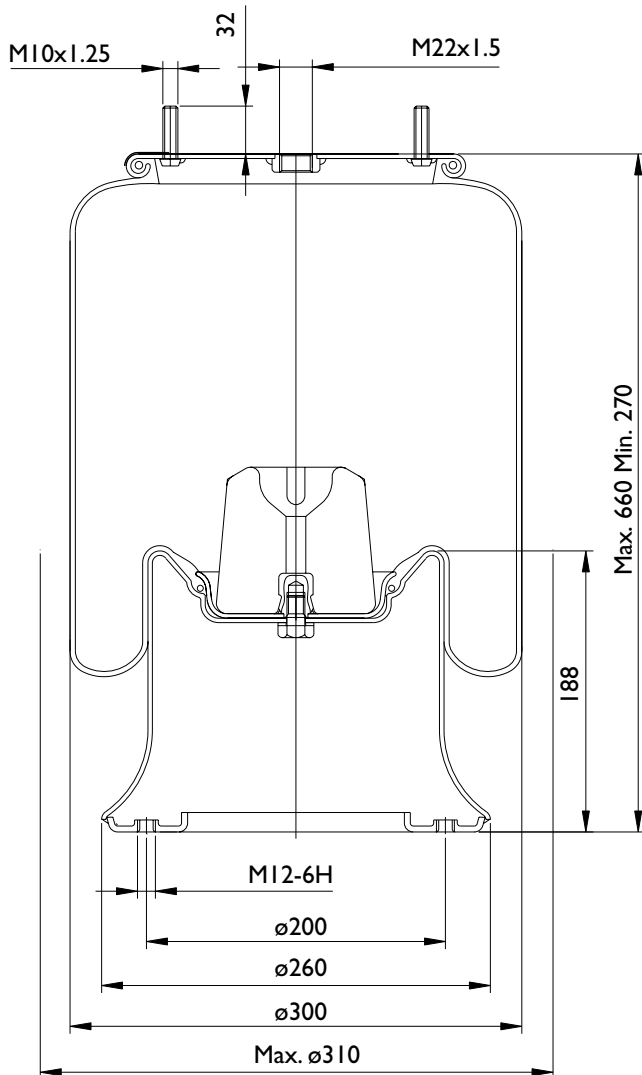

311105 Vista dall'alto

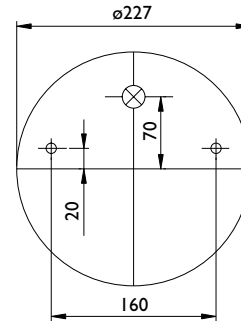

312010 Vista dal basso

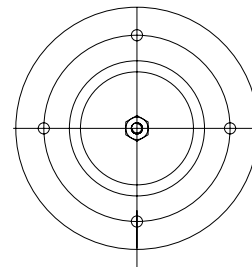

## Applicazioni principali

VIBERTI (fino al 03/91)	I28147109

## Lista corrispondenze

CONTITECH	
FIRESTONE	
PHOENIX	
TAURUS	
DUNLOP UK	D 13 B 06/10
DUNLOP F	
GOODYEAR	
PIRELLI	I T 323-40 / 96864
GART	D278H 278.4.514

⊗ Entrata aria

⊗ Perno combinato

# MOLLE AD ARIA COMPLETE



A520006C/I

AIRTECH® 391210 K/I

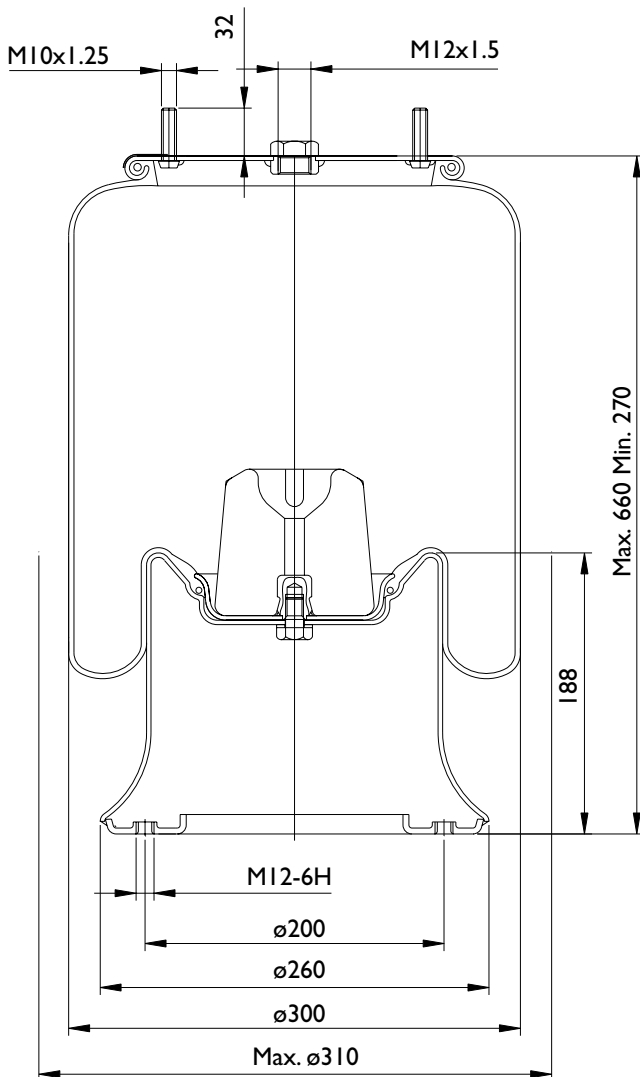

311105 Vista dall'alto

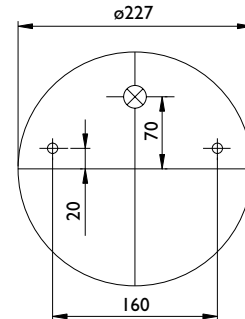

312010 Vista dal basso

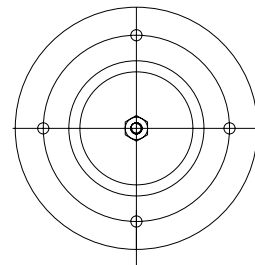

completo con 4 viti  
T.E. M12 x 70

## Applicazioni principali

VIBERTI (dal 03/01)	128147111

## Lista corrispondenze

CONTITECH	
FIRESTONE	
PHOENIX	
TAURUS	
DUNLOP UK	
DUNLOP F	
GOODYEAR	
PIRELLI	I T 323-40 BG / 97307
GART	



Entrata aria



Perno combinato



**A520168C**

**AIRTECH® 391210-01 K**

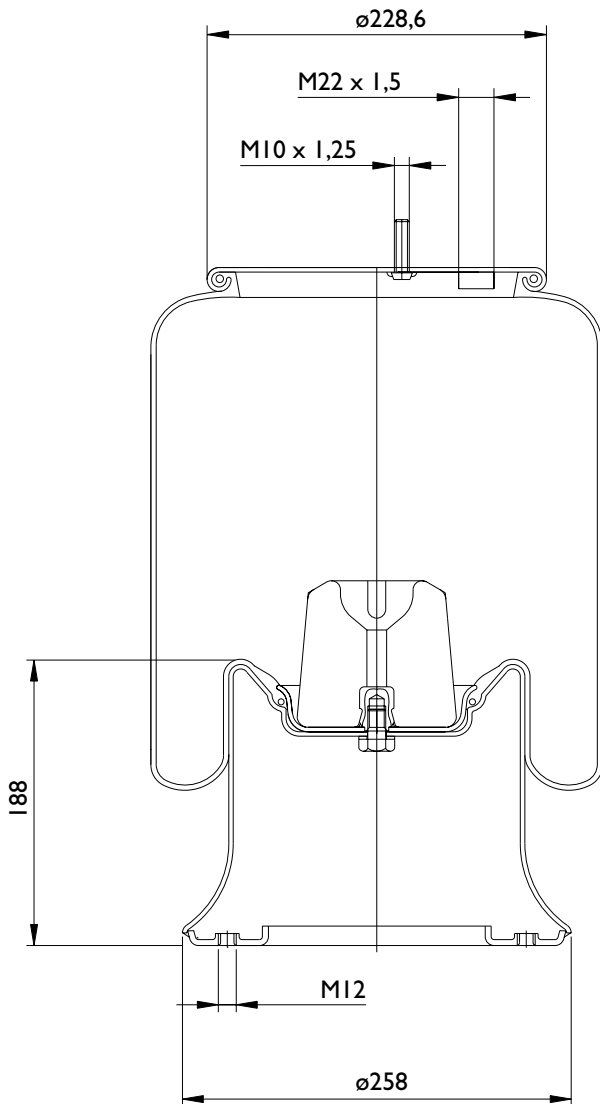

Vista dall'alto

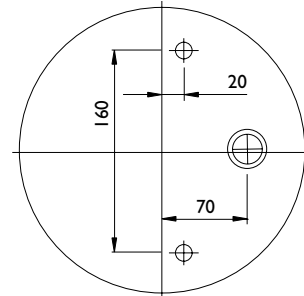

Vista dal basso

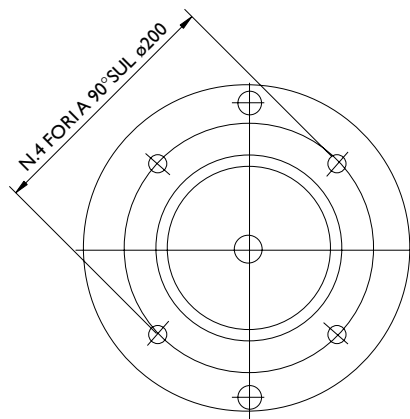

## Applicazioni principali

BATTAGLINO	0.41.03.007.0
B.P.W.	0.41.03.007.0
CAMPANA	05.050.0100

## Lista corrispondenze

CONTITECH	
FIRESTONE	
PHOENIX	
TAURUS	
DUNLOP UK	
DUNLOP F	
GOODYEAR	
PIRELLI	
GART	D278H 278.4.512

⊗ Entrata aria

⊗ Perno combinato

# MOLLE AD ARIA COMPLETE



A520012C

AIRTECH® 391303 K

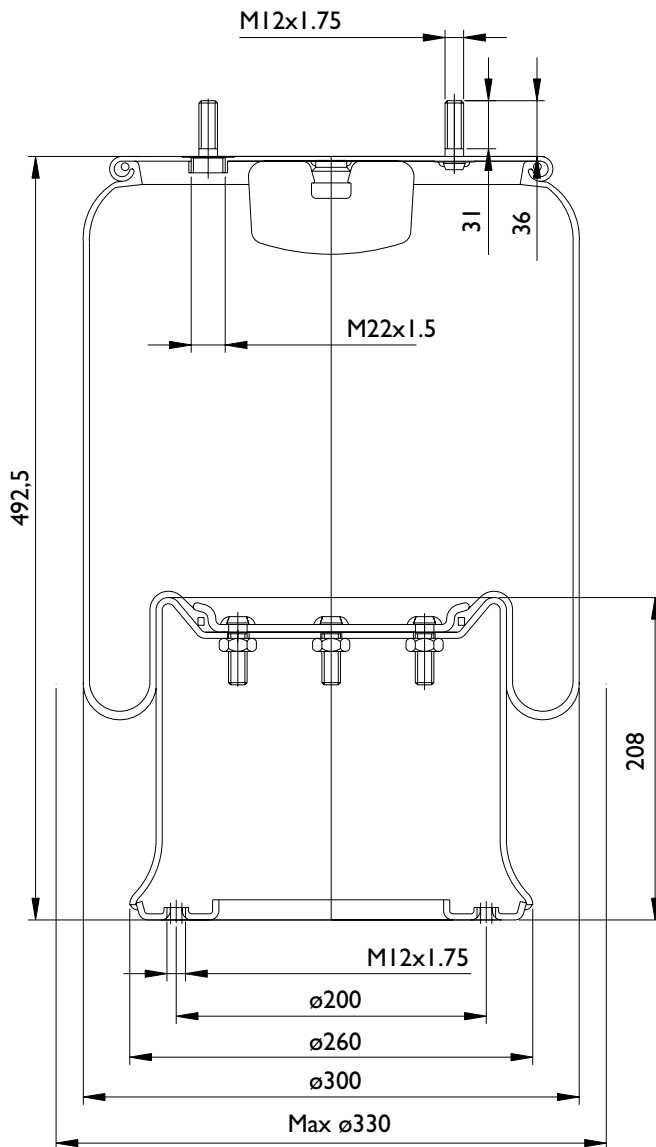

311003 Vista dall'alto

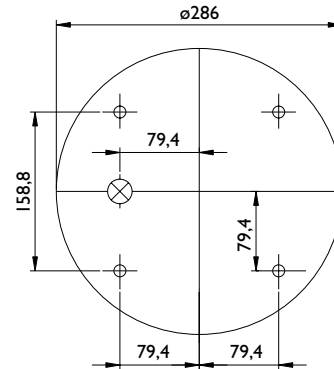

312022 Vista dal basso

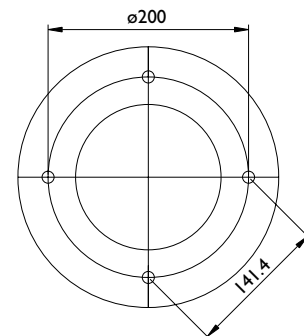

## Applicazioni principali

FRUEHAUF	UJB0305
ROR / MERITOR	21221349
SAF	3.229.0024.00
SAMRO	H25000361
ZORZI	
WEWELER	US07380

## Lista corrispondenze

CONTITECH	
FIRESTONE	IT 19 L-12 / W01 M58 7380/8765
PHOENIX	ID28H13
TAURUS	
DUNLOP UK	
DUNLOP F	D 13 B 03
GOODYEAR	
PIRELLI	IT19E3 / 97393
GART	D287/B 287.4.580

⊗ Entrata aria

⊗ Perno combinato

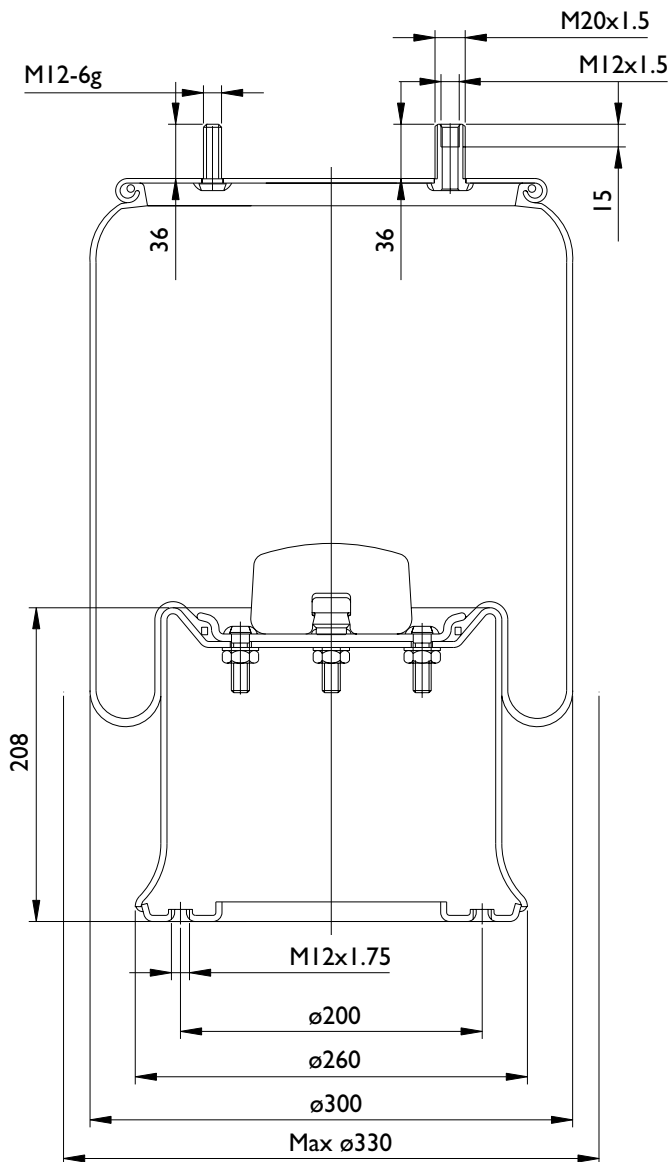

311103 Vista dall'alto

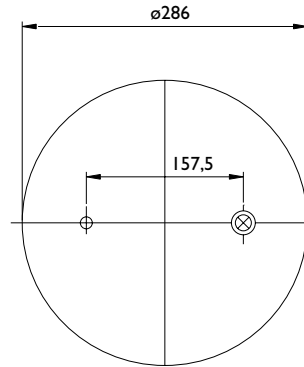

312022 Vista dal basso

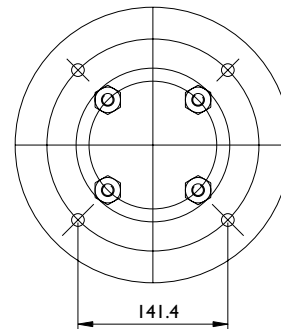

### Applicazioni principali

FRUEHAUF	M001464
ZORZI	1006552

### Lista corrispondenze

CONTITECH	
FIRESTONE	I T 19 L-14 / W01 M58 8762
PHOENIX	
TAURUS	
DUNLOP UK	
DUNLOP F	D 13 B 04
GOODYEAR	
PIRELLI	I T 19 E-3 / 201840
GART	

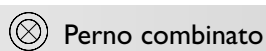
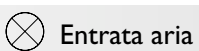

# MOLLE AD ARIA COMPLETE



## AIRTECH® 391305 K

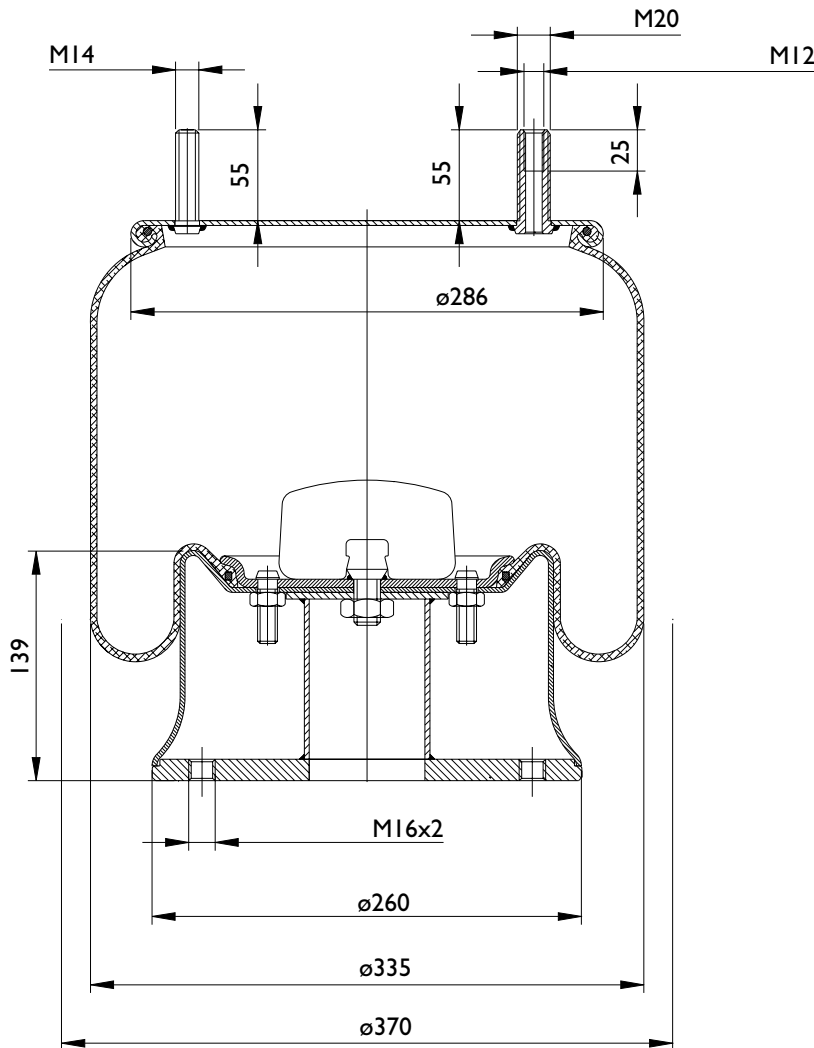

311104 Vista dall'alto

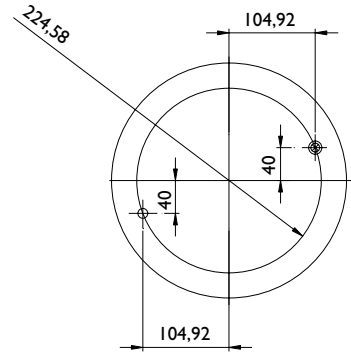

Vista dal basso

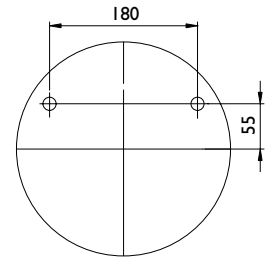

### Applicazioni principali

KAISER	F01004307

### Lista corrispondenze

CONTITECH	
FIRESTONE	
PHOENIX	
TAURUS	
DUNLOP UK	
DUNLOP F	D13 B05
GOODYEAR	
PIRELLI	
GART	

⊗ Entrata aria

⊗ Perno combinato



**A520020C**

**AIRTECH® 391314 K**

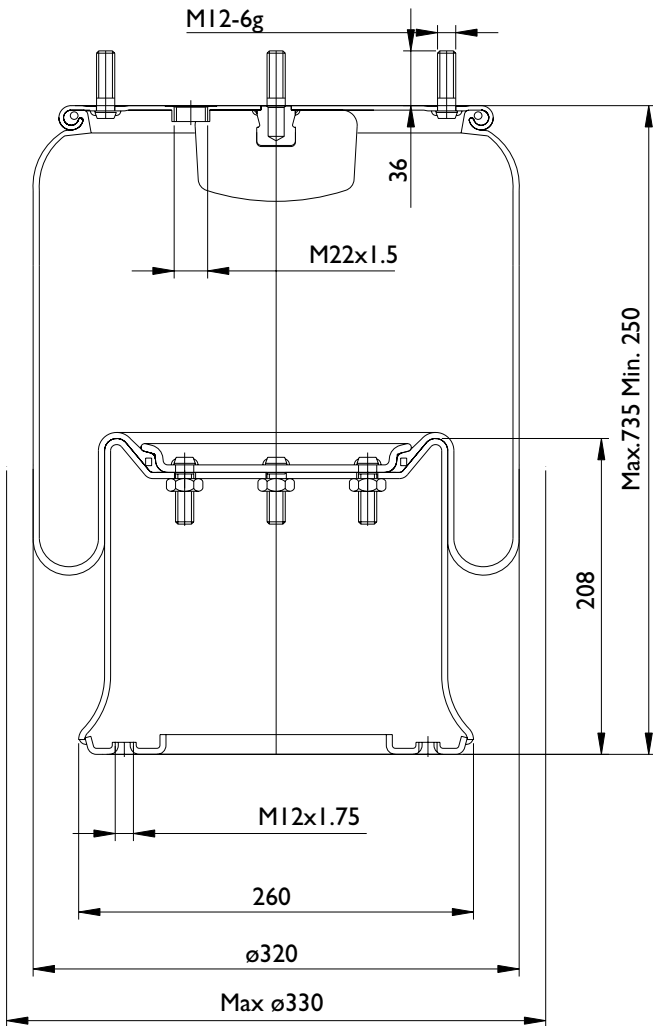

311106 Vista dall'alto

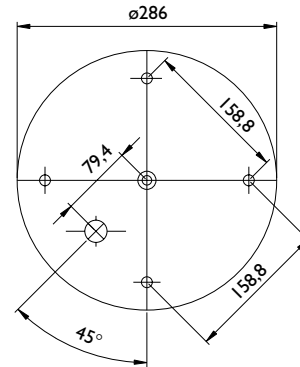

312022 Vista dal basso

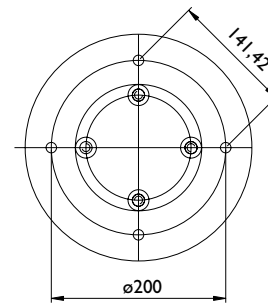

## Applicazioni principali

HENDRICKSON	Y507782
FRUEHAUF	M060770
FRUEHAUF	XCM 1331
ROR	21222673
SAF	3.229.0005.00
SAF	3.229.0006.01
SAF	3.229.0013.00
WEWELER	US 7385F

## Lista corrispondenze

CONTITECH	912 MB
FIRESTONE	1 T 19 L-14 / W01 M58 7385/8766
PHOENIX	ID 28 D2
TAURUS	
DUNLOP UK	
DUNLOP F	D 13 B14
GOODYEAR	
PIRELLI	
GART	

⊗ Entrata aria

⊗ Perno combinato



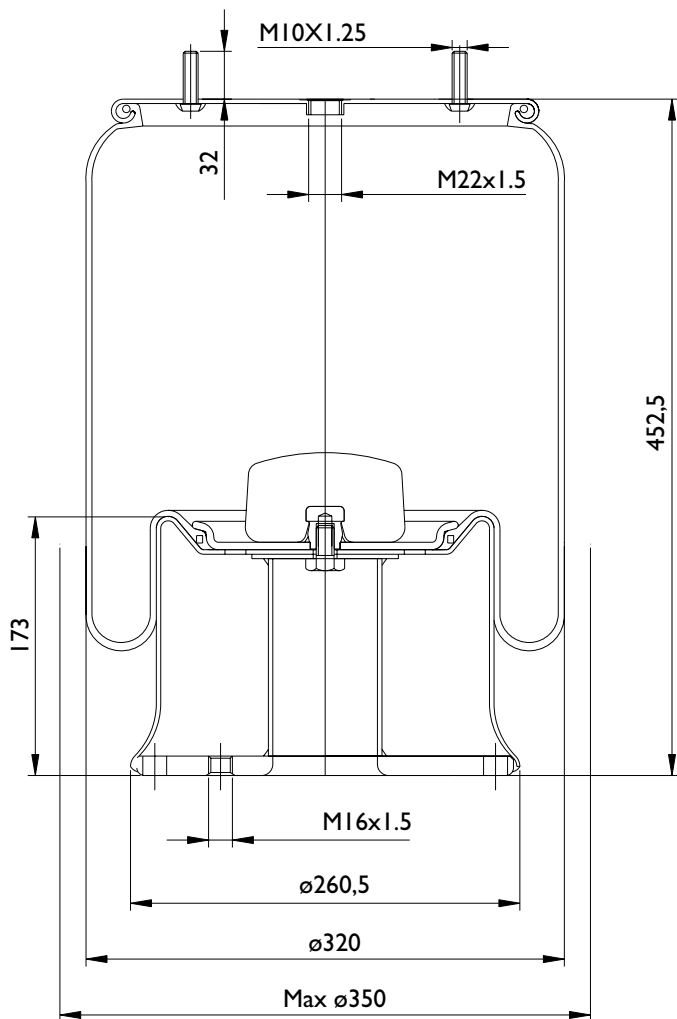

311017 Vista dall'alto

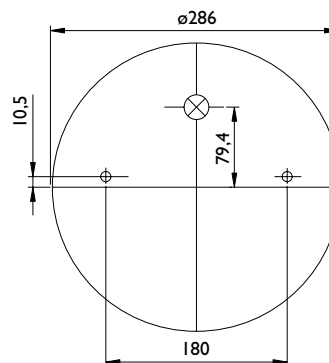

312041 Vista dal basso

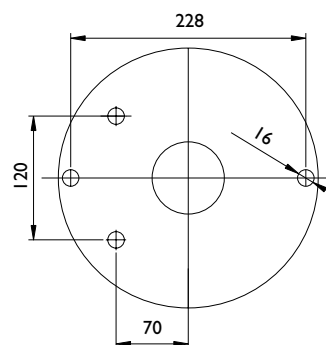

### Applicazioni principali

BARTOLETTI	91619011
BATTAGLINO	2211401
CARDI	58050700
DAF	67306
MICHIELETTO	0006061
OMAR	11804
ROLFO	112060
VIBERTI (fino 03/91)	128147102
ZORZI	1006553

### Lista corrispondenze

CONTITECH	811 MB
FIRESTONE	1 T 19 L-11 / W01 M58 6361
PHOENIX	
TAURUS	K 622-26 SM
DUNLOP UK	PNP 311670000
DUNLOP F	D 13 B 18/12
GOODYEAR	1 R 14-706
PIRELLI	1 T 19 E-2 204371
GART	D277/2F 277.2.500



Entrata aria



Perno combinato



**A520021C/I**

**AIRTECH® 391318 K/I**

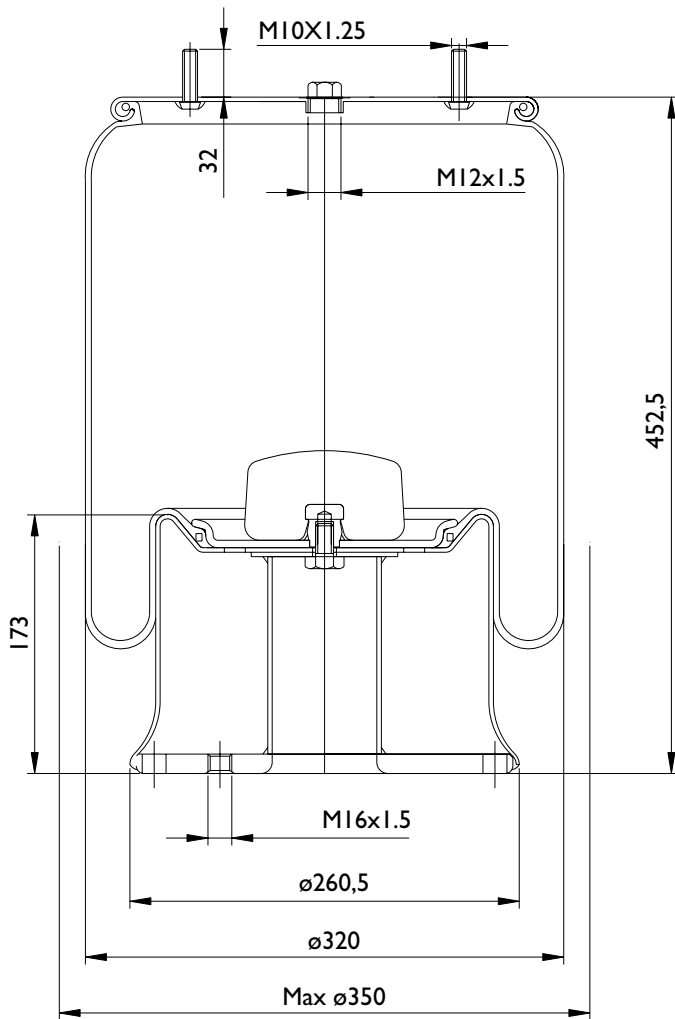

311017 Vista dall'alto

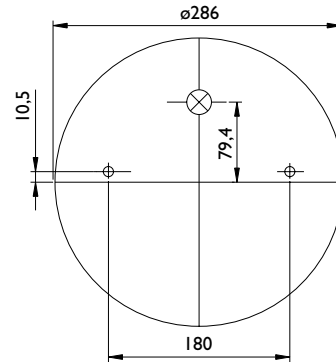

312041 Vista dal basso

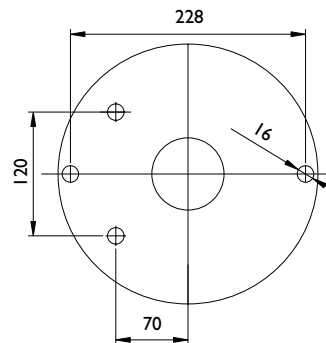

## Applicazioni principali

VIBERTI (dal 03/01)	128147112

## Lista corrispondenze

CONTITECH	811 MB
FIRESTONE	1 T 19 F-11
PHOENIX	
TAURUS	
DUNLOP UK	
DUNLOP F	
GOODYEAR	
PIRELLI	1 T 19 E-2 97730
GART	D277/2F 277.2.504

⊗ Entrata aria

⊗ Perno combinato

# MOLLE AD ARIA COMPLETE



A520049C

AIRTECH® 391320 K

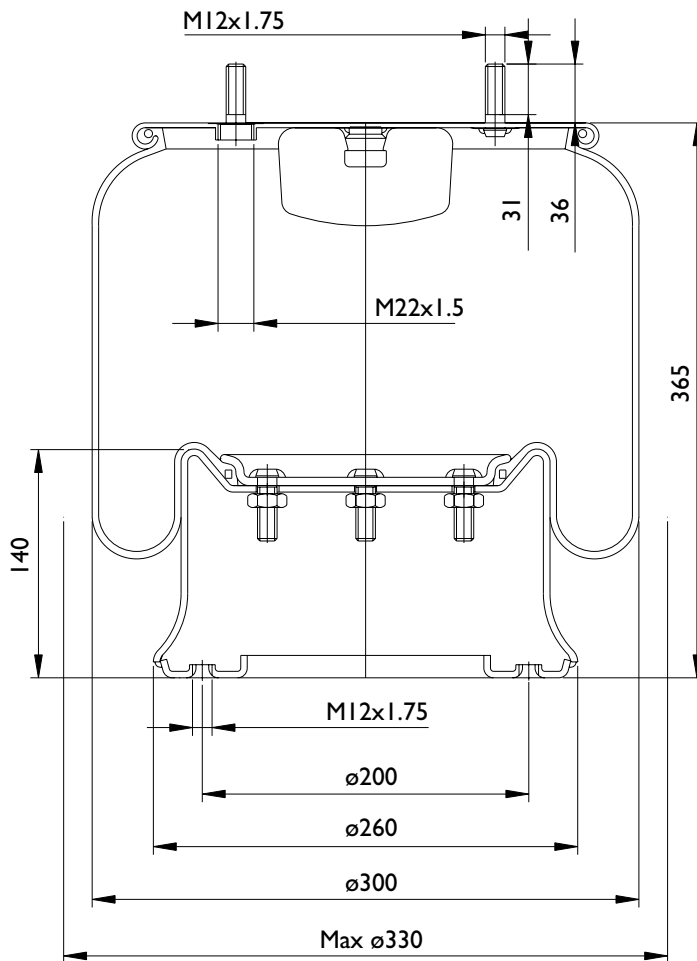

311003 Vista dall'alto

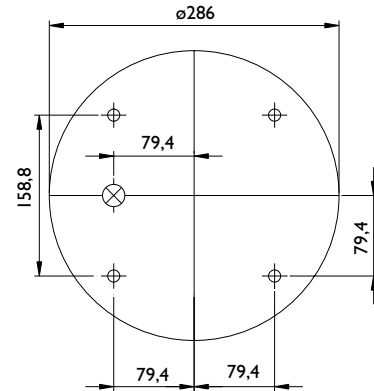

312016 Vista dal basso

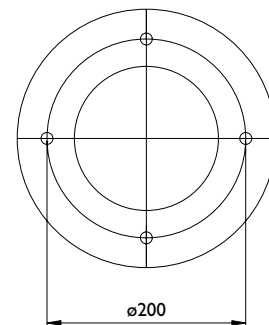

## Applicazioni principali

SAE	9212050
TROUILLET	HB10315
WEWELER	US07337F
YORK	506243/01

## Lista corrispondenze

CONTITECH	810 MB
FIRESTONE	I T 19 L-7 / W01 M58 6345/7337
PHOENIX	
TAURUS	B 104/K104
DUNLOP UK	PNP 311780000
DUNLOP F	D 13 B 01/20
GOODYEAR	I R 14-059
PIRELLI	I T 19 E-I / 87413/I
GART	



Entrata aria



Perno combinato



**A520074C**

**AIRTECH® 391323 K**

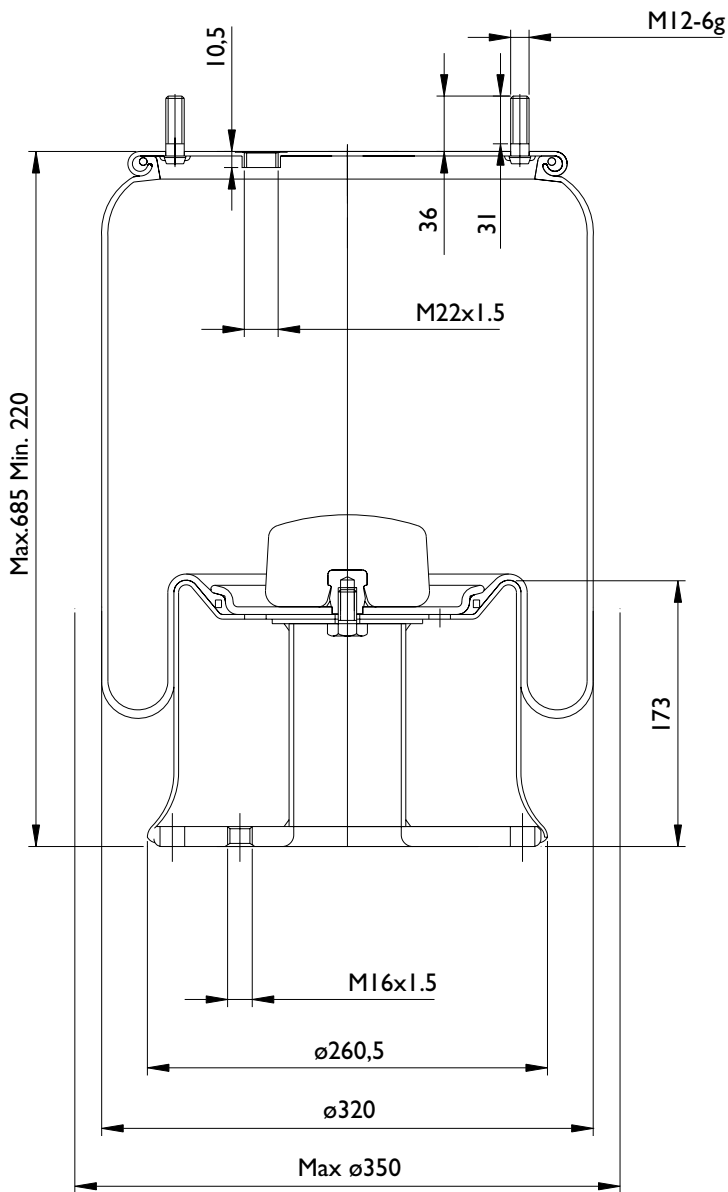

311004 Vista dall'alto

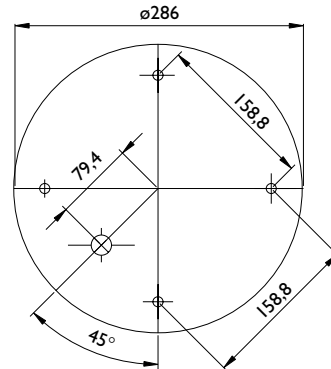

312041 Vista dal basso

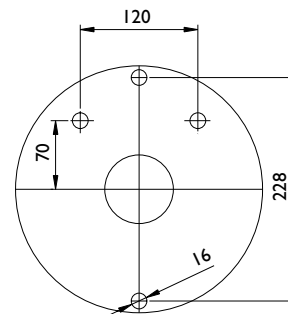

## Applicazioni principali

MICHIELETTO	0001004

## Lista corrispondenze

CONTITECH	
FIRESTONE	
PHOENIX	
TAURUS	
DUNLOP UK	
DUNLOP F	D 13 B 23
GOODYEAR	
PIRELLI	
GART	

⊗ Entrata aria

⊗ Perno combinato

# MOLLE AD ARIA COMPLETE



## AIRTECH® 391324 K

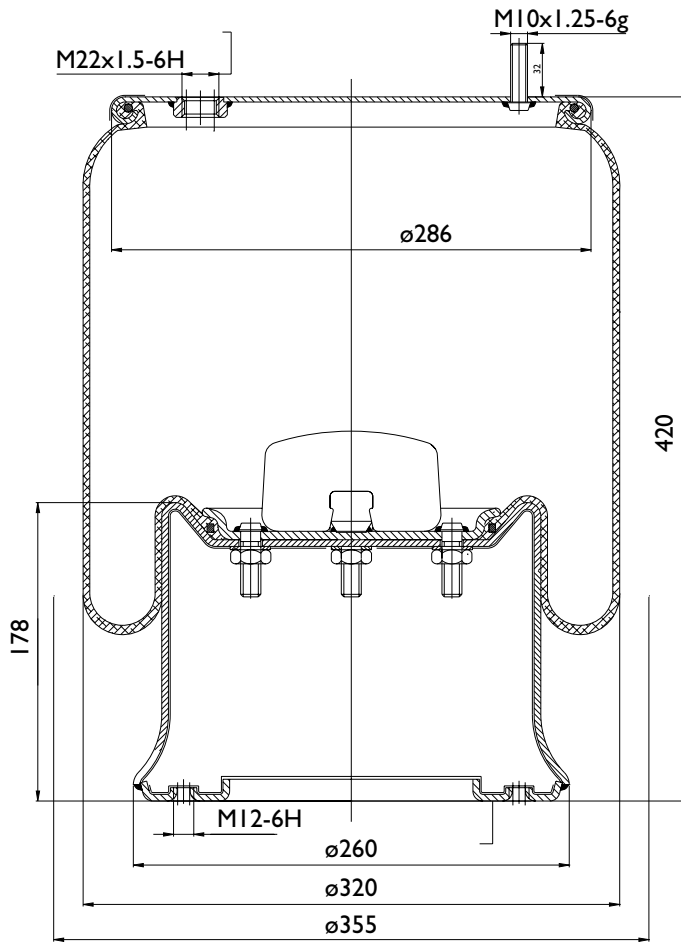

311138 Vista dall'alto

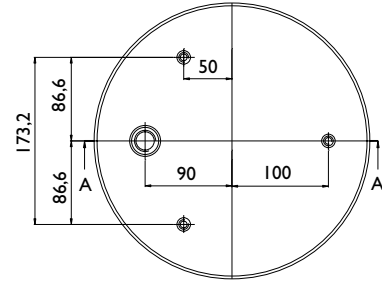

312014 Vista dal basso

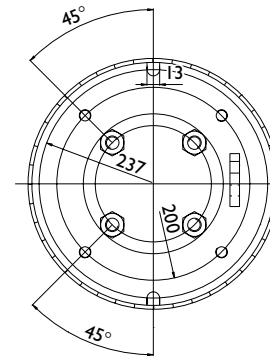

### Applicazioni principali

DAF	SB3000

### Lista corrispondenze

CONTITECH	811 MB 3
FIRESTONE	IT 19 F-11/W01 M 58 6359/6334
PHOENIX	
TAURUS	
DUNLOP UK	
DUNLOP F	D 13 B 24
GOODYEAR	IR11-703
PIRELLI	IT 19 E-2 / 203878
GART	

⊗ Entrata aria

⊗ Perno combinato

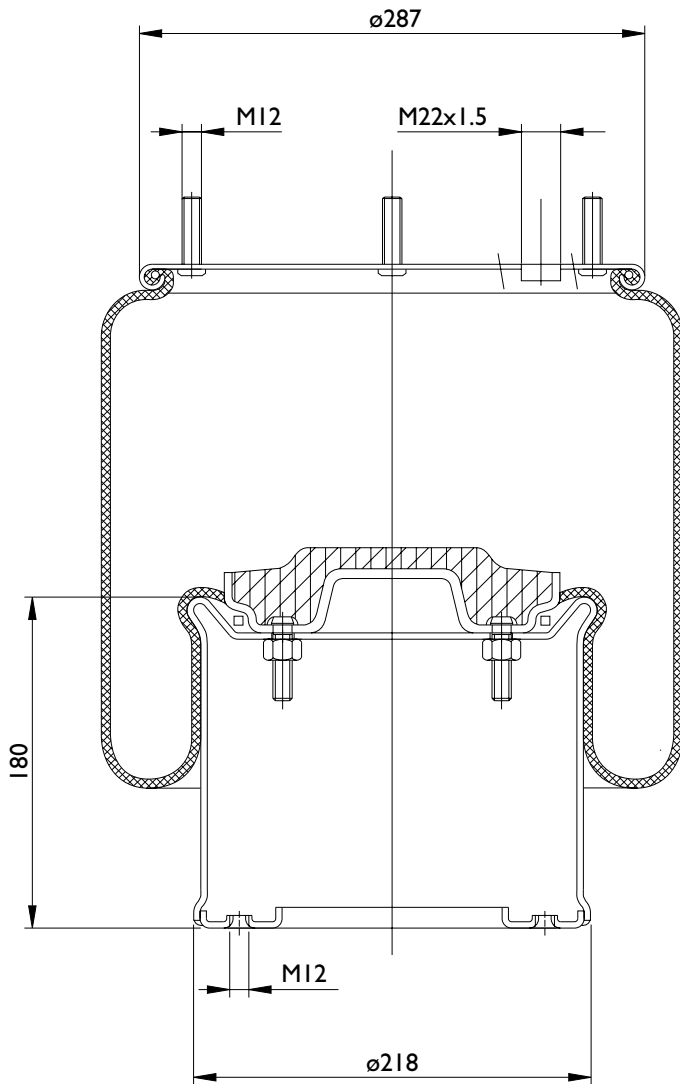

Vista dall'alto

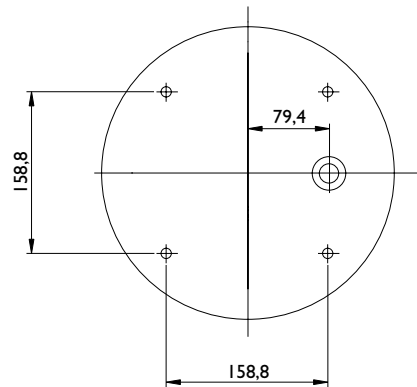

Vista dal basso

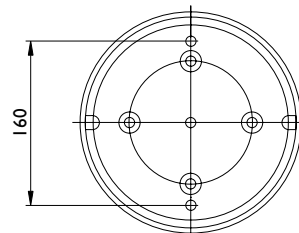

### Applicazioni principali

BPW	041030160

### Lista corrispondenze

CONTITECH	
FIRESTONE	
PHOENIX	
TAURUS	
DUNLOP UK	
DUNLOP F	
GOODYEAR	
PIRELLI	
GART	D277/DA 277.4.523

⊗ Entrata aria

⊙ Perno combinato

## MOLLE AD ARIA A LOBI







# MOLLE AD ARIA A LOBI



A520161

**AIRTECH®** 220-60 / 111150

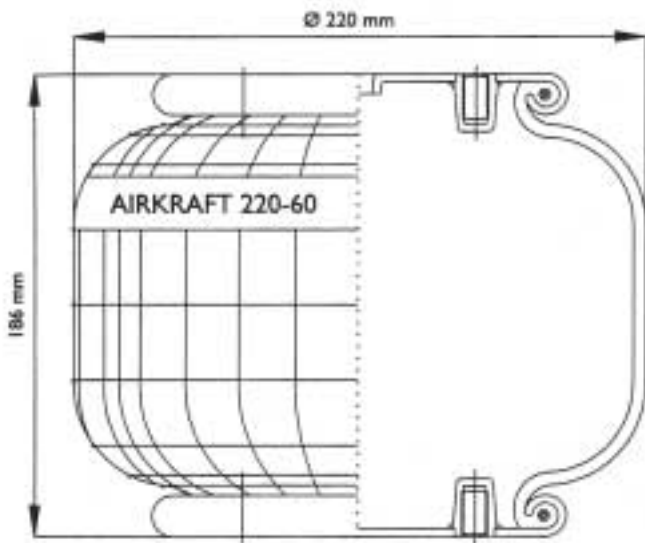

311210 Vista dall'alto

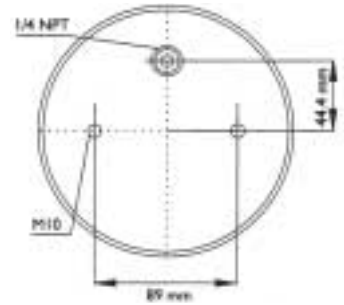

311002 Vista dal basso

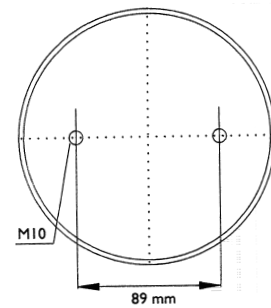

## Applicazioni principali



## Lista corrispondenze

CONTITECH	
FIRESTONE	
PHOENIX	
TAURUS	
DUNLOP UK	
DUNLOP F	
GOODYEAR	
PIRELLI	
GART	T291 / B (291.I.170)

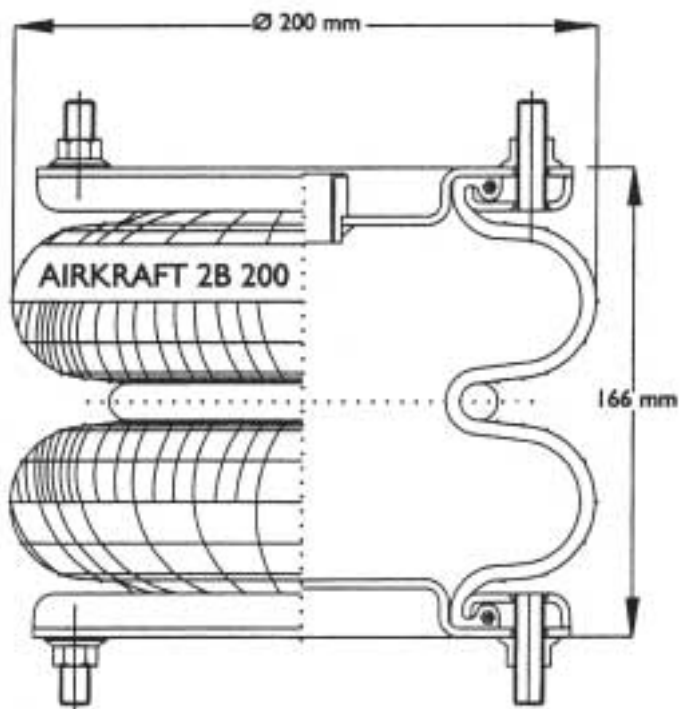

**A520141**

**AIRTECH® 2B-200 / 113060**



H. min. = 75  
H. max. = 250

311211 Anello di fissaggio  
311177 Vista dall'alto

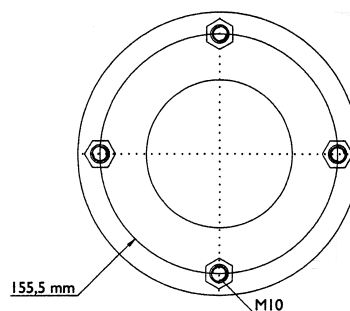
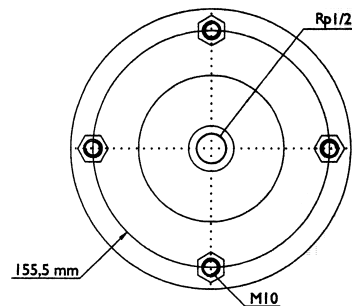

## Applicazioni principali

FRUEHAUF	F48054M80A04
GRANNING	I5803
LOHR	A06030604
SAMRO	H2500188

## Lista corrispondenze

CONTITECH	FD 138-18
FIRESTONE	
PHOENIX	
TAURUS	
DUNLOP UK	
DUNLOP F	SP 1490
GOODYEAR	
PIRELLI	
GART	

# MOLLE AD ARIA A LOBI



A520079

**AIRTECH®** 2B-220 / 113001

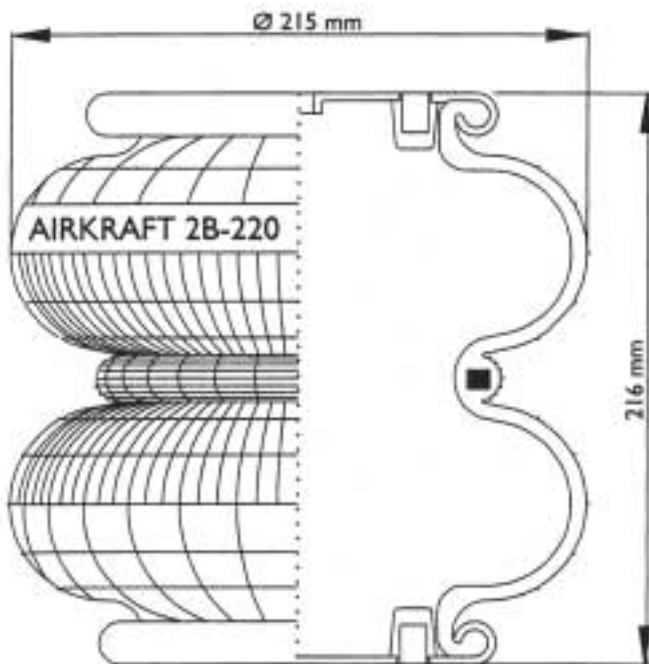

H. min. = 80

H. max. = 235

Capacità di carico a 7 bar = 11,5 kW

311001 Vista dall'alto

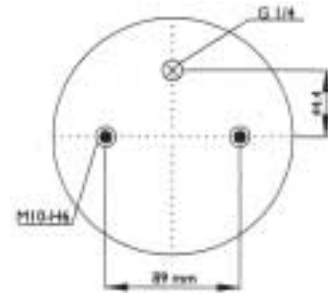

311002 Vista dal basso

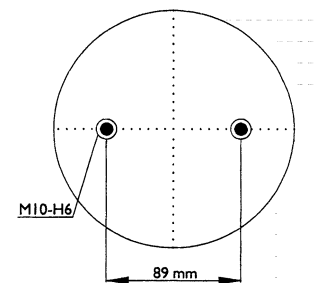

## Applicazioni principali

DAF (Truck)	0654464 Metric
GRANNING	15603
HENDRICKSON-DISCOS	NA 1827
MERITOR	21221395-21222663
PEGASO	528919 5266/5231/5236
ROR	212221395-21222663
VOLVO	365461 Bus B 58-365431
VOLVO	6882797
WELWELER	US 06910 F

## Lista corrispondenze

CONTITECH	FD 200-19 M8
FIRESTONE	W01.M58-6887/6910
PHOENIX	2B 12R
TAURUS	
DUNLOP UK	
DUNLOP F	9"1/4 SO 9201
GOODYEAR	
PIRELLI	
GART	T291/2 (291.2.200)

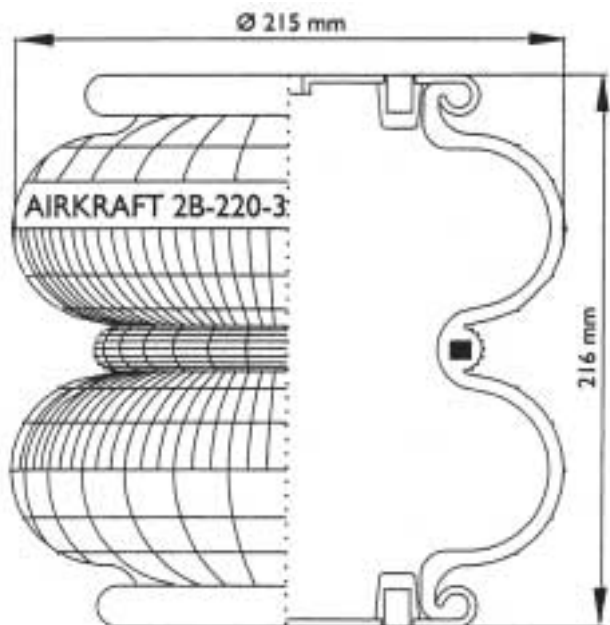

311005 Vista dall'alto

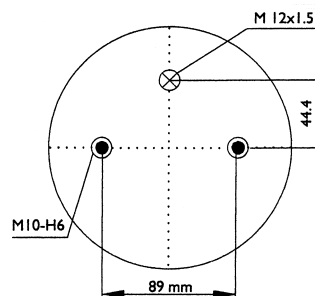

311002 Vista dal basso

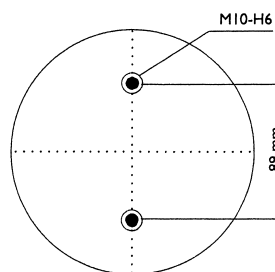

H. min. = 80

H. max. = 265

Capacità di carico a 7 bar = 17 kW

### Applicazioni principali

GRANNING	I5599
SAF	I600 4.229.1004.00
SCANIA	I31 9761
SCANIA	I387289

### Lista corrispondenze

CONTITECH	895 N
FIRESTONE	W01.M58-7894
PHOENIX	2B 12R-3
TAURUS	
DUNLOP UK	
DUNLOP F	
GOODYEAR	
PIRELLI	T20 86660
GART	

# MOLLE AD ARIA A LOBI



A520119

**AIRTECH® 2B-255 / 113100**

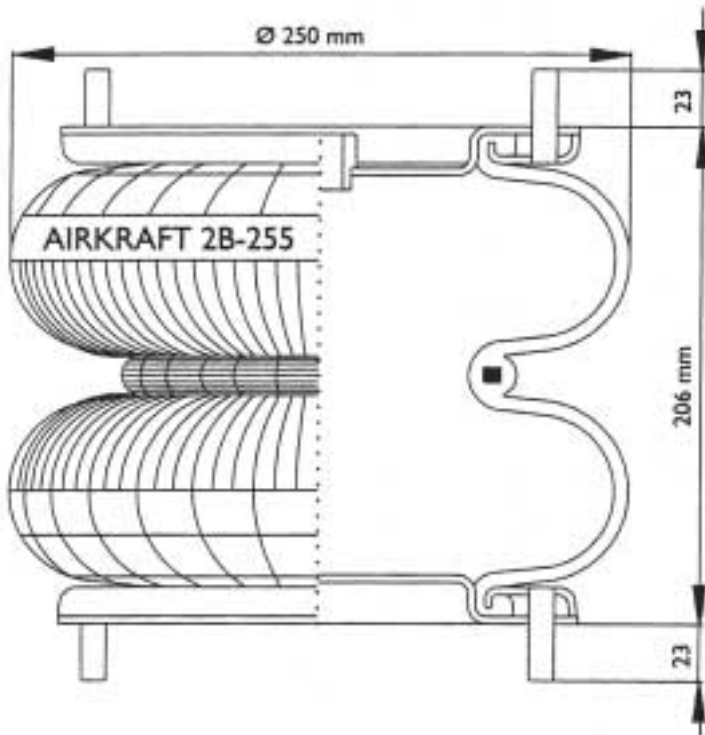

H. min. = 70  
 H. max. = 270  
 Capacità di carico a 7 bar = 21 kW

311030 Anello di fissaggio  
 311031 Vista dall'alto

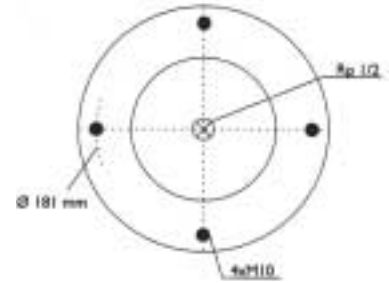

311030 Anello di fissaggio  
 311032 Vista dal basso

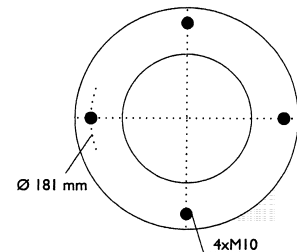

## Applicazioni principali

GRANNING	I5807
SAMRO	H 250-0021

## Lista corrispondenze

CONTITECH	FD 210-22
FIRESTONE	
PHOENIX	
TAURUS	
DUNLOP UK	
DUNLOP F	SPI538
GOODYEAR	
PIRELLI	
GART	

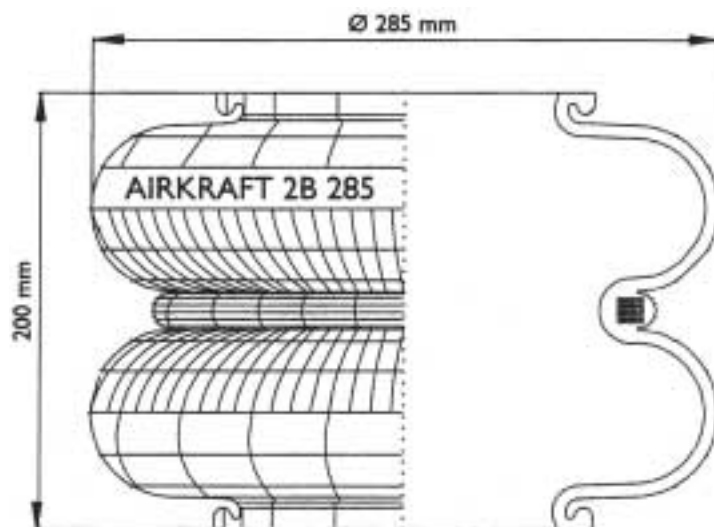

H. min. = 75

H. max. = 330

Capacità di carico a 7 bar = 28,5 kW

**Applicazioni principali**

BPW	02 2002 05 00
GRANNING	15923
KASSBOHRER	4731003000
MAGIRUS	0342 2571
MAN	81 43601 0022
MAN	88 96420 0217

**Lista corrispondenze**

CONTITECH	608 N
FIRESTONE	
PHOENIX	2B 20R
TAURUS	F211-200
DUNLOP UK	
DUNLOP F	
GOODYEAR	
PIRELLI	
GART	

# MOLLE AD ARIA A LOBI



A520109

**AIRTECH® 2B-300 / 113300**

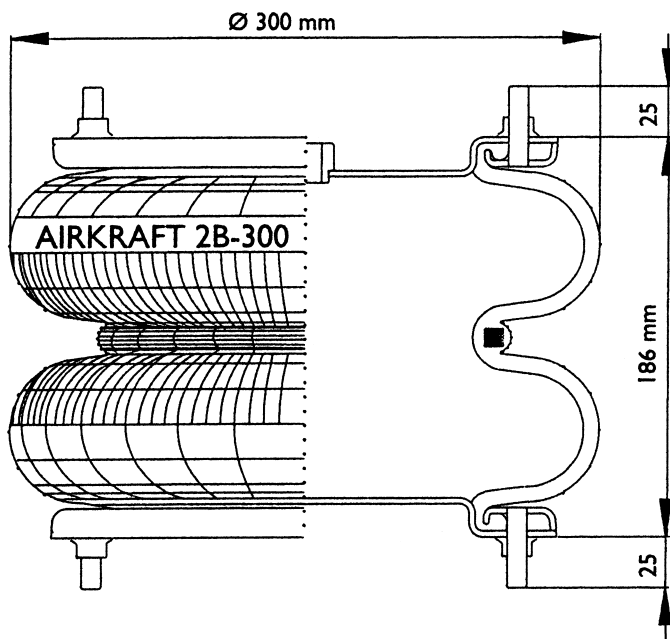

H. min. = 75

H. max. = 270

Capacità di carico a 7 bar = 32 kW

311007 Anello di fissaggio

311008 Vista dall'alto

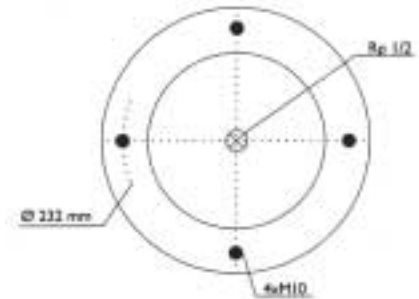

311007 Anello di fissaggio

311009 Vista dal basso

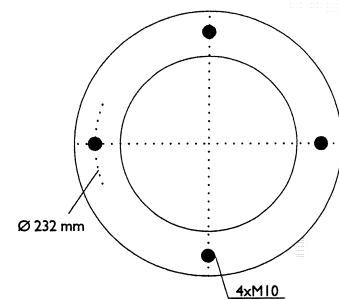

## Applicazioni principali

GIGANT	881202
GRANNING	15813
WEWELER	USN 5100 I I KD

## Lista corrispondenze

CONTITECH	FD 412-18
FIRESTONE	
PHOENIX	
TAURUS	
DUNLOP UK	
DUNLOP F	SP 1541 NB
GOODYEAR	
PIRELLI	
GART	



**A520110**

**AIRTECH® 2B-300 / 113301**

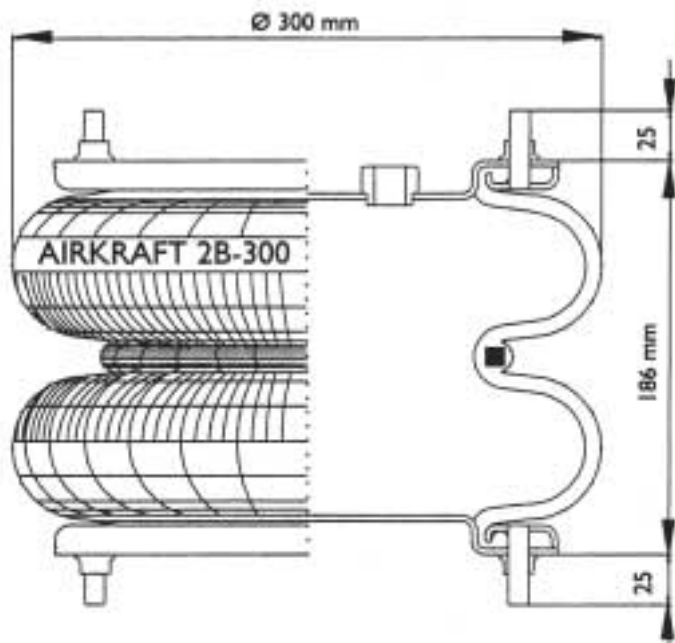

H. min. = 70

H. max. = 270

Capacità di carico a 7 bar = 32 kW

311007 Anello di fissaggio

311009 Vista dall'alto

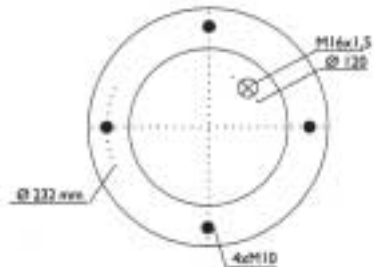

311007 Anello di fissaggio

311010 Vista dal basso

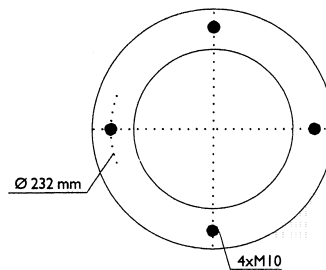

## Applicazioni principali

BENALU	M 063 796
GRANNING	I5814
GT-FRUEHAUF	UJB 09 85/A
KAISER	A 060 30 615
LOHR	A 063 0601
SMB	M 063 796
TRAILOR	UJB 09 85/A
TROUILLET	HB 10350

## Lista corrispondenze

CONTITECH	
FIRESTONE	
PHOENIX	
TAURUS	
DUNLOP UK	
DUNLOP F	SP 2665
GOODYEAR	
PIRELLI	
GART	



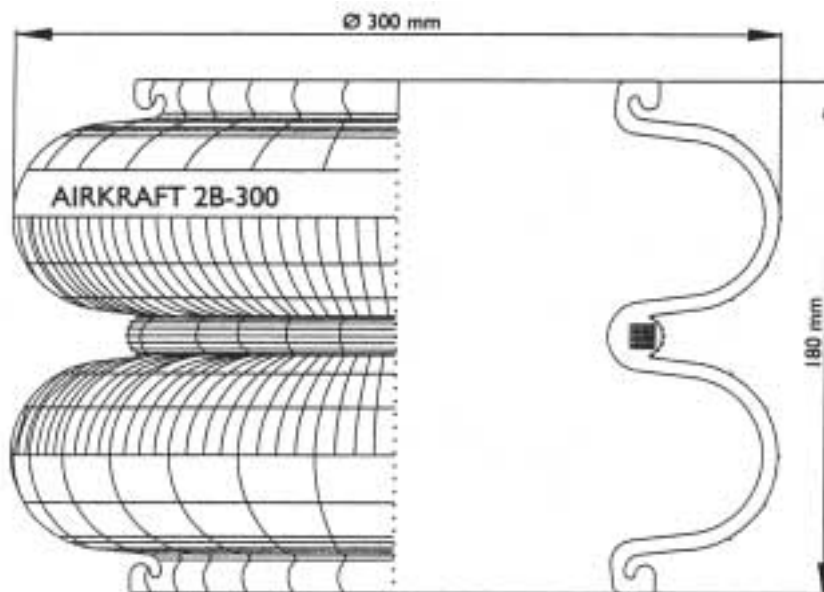

H. min. = 75

H. max. = 270

Capacità di carico a 7 bar = 32 kW

### Applicazioni principali

GRANNING	I5815
KAISER	A 060 30 616
LOHR	Y 0000 1737
METRO BUS	X 664 1055

### Lista corrispondenze

CONTITECH	
FIRESTONE	
PHOENIX	
TAURUS	
DUNLOP UK	
DUNLOP F	SP 256 NB (VSM 10178)
GOODYEAR	
PIRELLI	
GART	



**A520137**

**AIRTECH® 2B-370-Hyd / 113361**

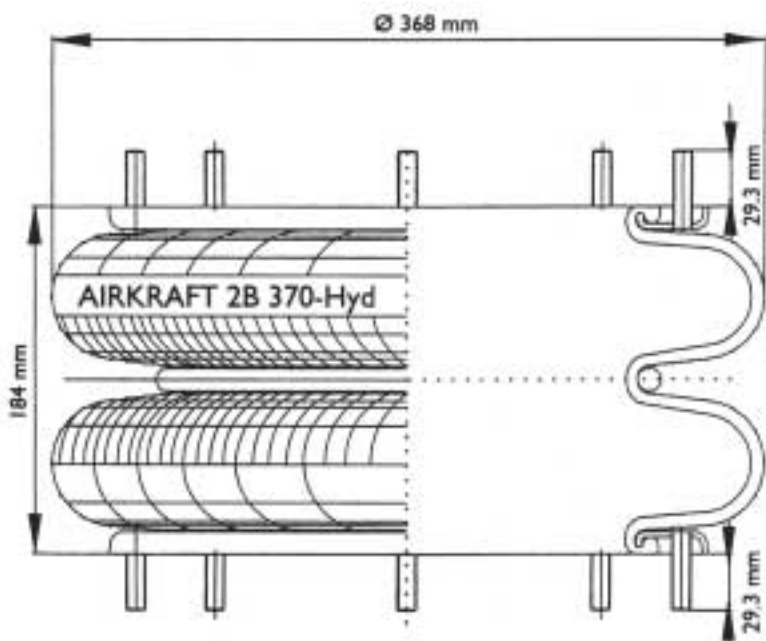

311105 Anello di fissaggio

Vista dall'alto / Vista dal basso

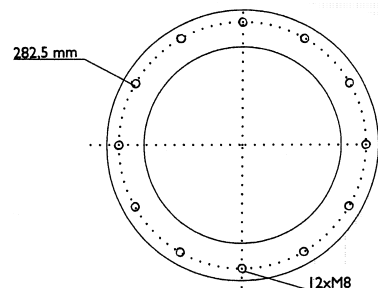

H. min. = 70

H. max. = 340

Capacità di carico a 7 bar = 45 kW

## Applicazioni principali

AUSTERAS	99381024
BATAGLINO	041040040
CAMPANA	050500400
CARDI	58053300
IVECO	8194818
TRAS CAR	03003000020
VIBERTI	128 118 102

## Lista corrispondenze

CONTITECH	
FIRESTONE	
PHOENIX	
TAURUS	
DUNLOP UK	
DUNLOP F	SP 2599
GOODYEAR	
PIRELLI	21BR 89457
GART	T274 274.2.210

# MOLLE AD ARIA A LOBI



A520108

**AIRTECH®** 3B-300 / 115002

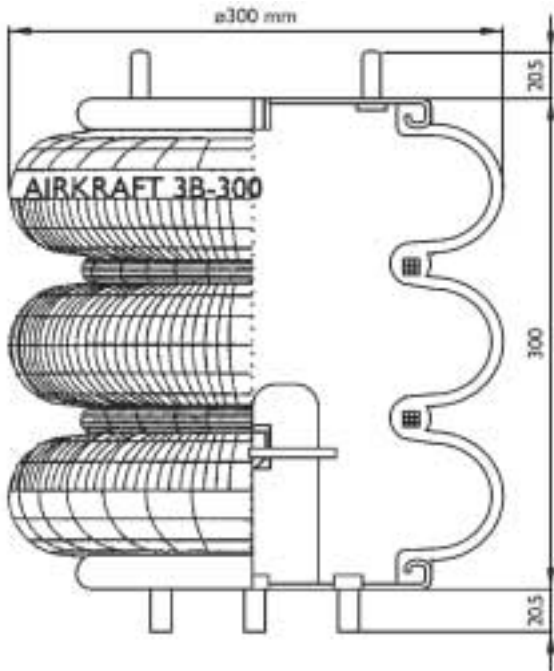

H. min. = 120  
 H. max. = 430  
 Capacità di carico a 7 bar = 35 kW

311003 Vista dall'alto

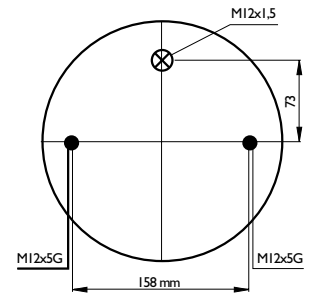

311004 Vista dal basso

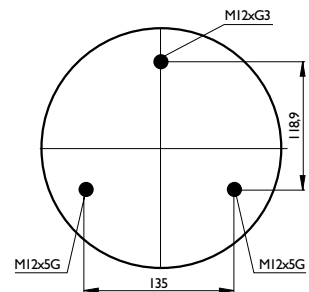

## Applicazioni principali

## Lista corrispondenze

CONTITECH	
FIRESTONE	
PHOENIX	
TAURUS	
DUNLOP UK	
DUNLOP F	
GOODYEAR	
PIRELLI	
GART	T271 / S 271.3.296

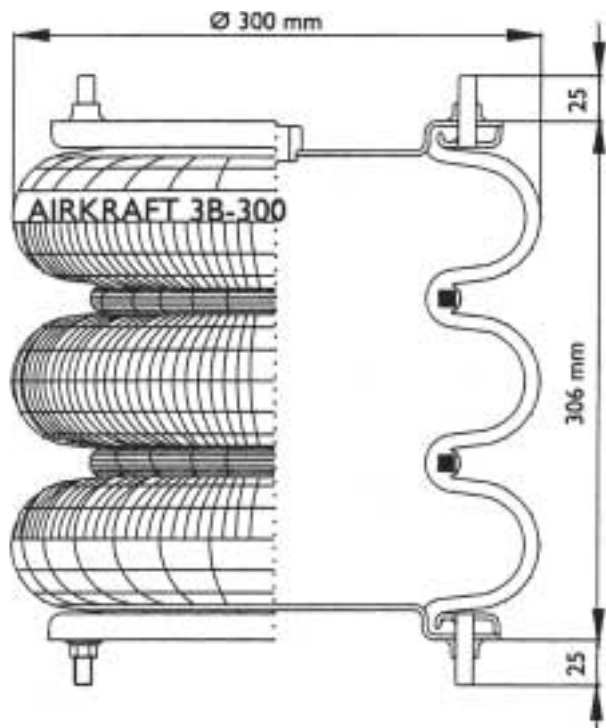

H. min. = 100

H. max. = 430

Capacità di carico a 7 bar = 35 kW

311007 Anello di fissaggio

311008 Vista dall'alto

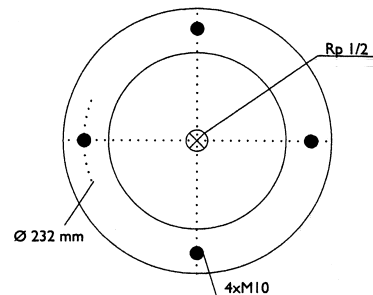

311007 Anello di fissaggio

311010 Vista dal basso

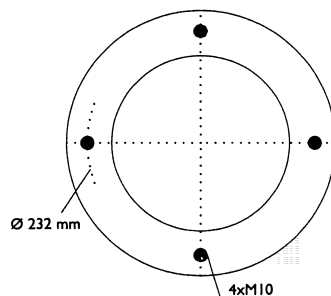

### Applicazioni principali

GIGANT	881204
GRANNING	15816

### Lista corrispondenze

CONTITECH	FT 412-32
FIRESTONE	
PHOENIX	
TAURUS	
DUNLOP UK	PNP 305 520 178
DUNLOP F	SP 1542
GOODYEAR	
PIRELLI	
GART	

# MOLLE AD ARIA A LOBI



A520107

**AIRTECH® 3B-300 / 115004**

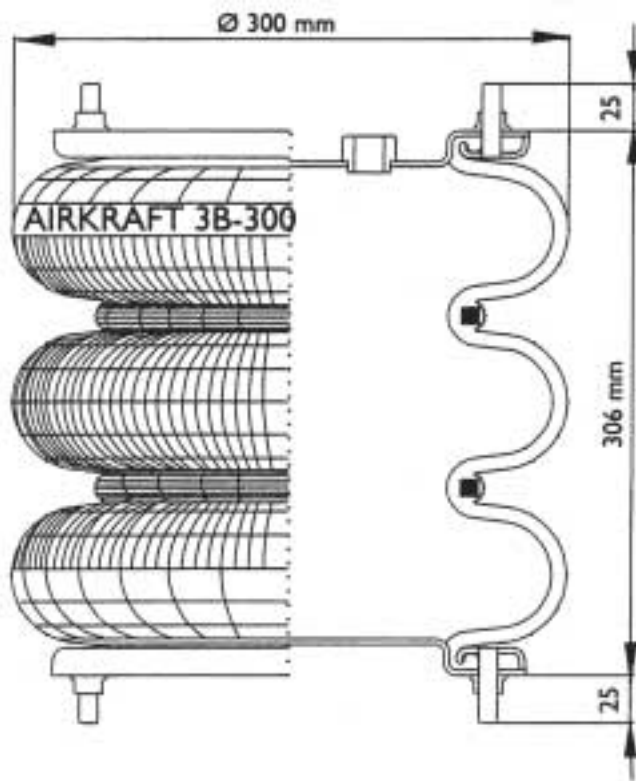

H. min. = 100  
 H. max. = 430  
 Capacità di carico a 7 bar = 35 kW

311007 Anello di fissaggio  
 311009 Vista dall'alto

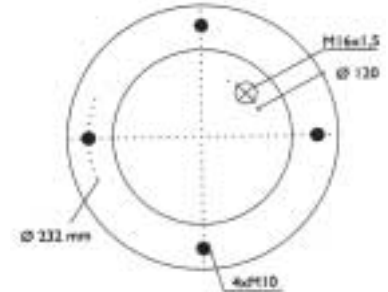

311007 Anello di fissaggio  
 311010 Vista dal basso

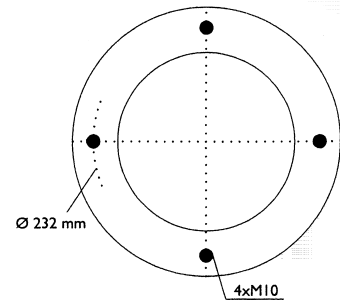

## Applicazioni principali

BENALU	M 00 2297
GRANNING	15897
GT FRUEHAUF (Traylor)	M 002 297
LOHR	A 060 30 606
SAMRO	H 250-0011
SMB	M 002 297

## Lista corrispondenze

CONTITECH	
FIRESTONE	
PHOENIX	
TAURUS	
DUNLOP UK	
DUNLOP F	SP 2666
GOODYEAR	
PIRELLI	
GART	



**A520136**

**AIRTECH® 3B-300-Hyd / 115005**

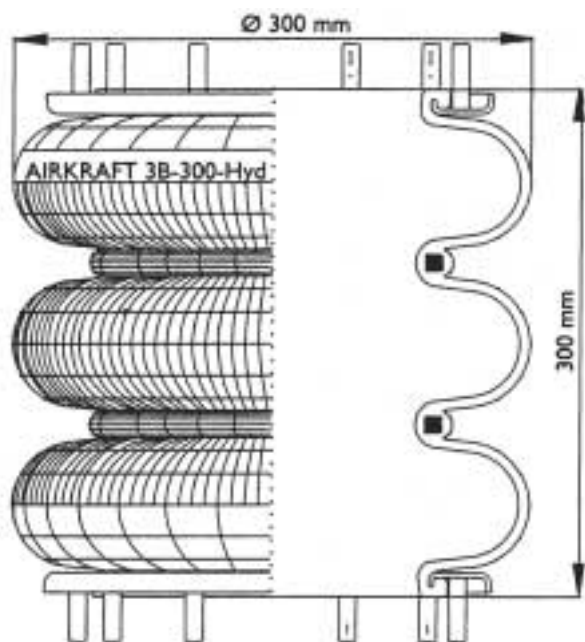

311093 Anello di fissaggio

Vista dall'alto / Vista dal basso

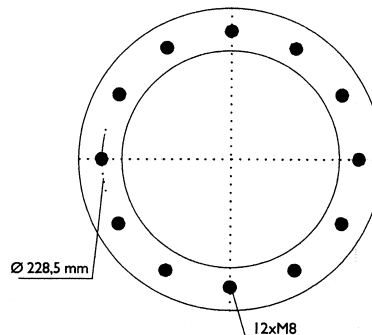

H. min. = 100

H. max. = 420

Capacità di carico a 7 bar = 35 kW

## Applicazioni principali

BARTOLETTI	91621322
IVECO	42107595
VIBERTI	128 118 103
ZORZI	100 6505

## Lista corrispondenze

CONTITECH	
FIRESTONE	
PHOENIX	
TAURUS	
DUNLOP UK	
DUNLOP F	SP 2597 RE
GOODYEAR	
PIRELLI	322BR 89413
GART	T271 271.3.293

# MOLLE AD ARIA A LOBI



A520114

**AIRTECH®** 3B-400-Hyd / 115155

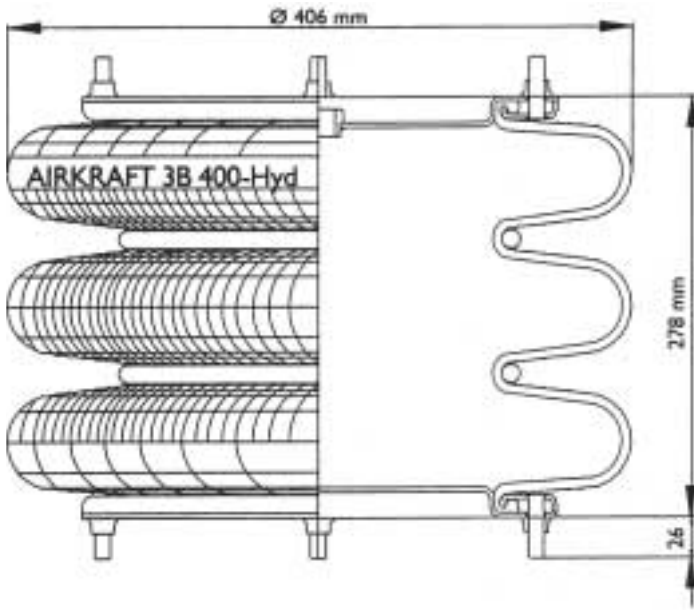

311036 Anello di fissaggio  
311046 Vista dall'alto

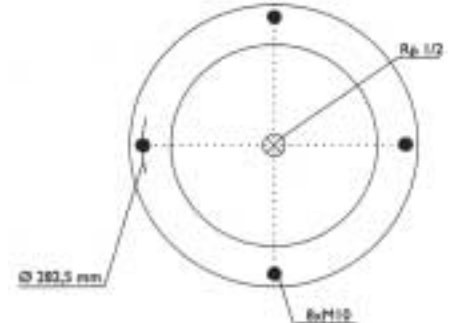

311036 Anello di fissaggio  
311035 Vista dal basso

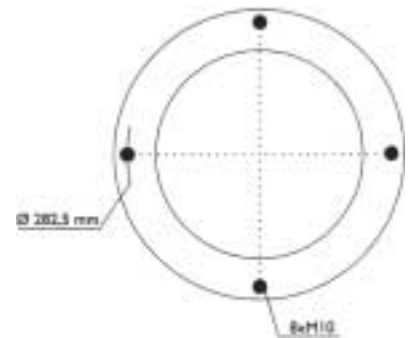

## Applicazioni principali

GRANNING	I5832
KAISER	WC 074 0236

## Lista corrispondenze

CONTITECH	
FIRESTONE	
PHOENIX	
TAURUS	
DUNLOP UK	PNP 313 170 100
DUNLOP F	SP 2141
GOODYEAR	
PIRELLI	
GART	

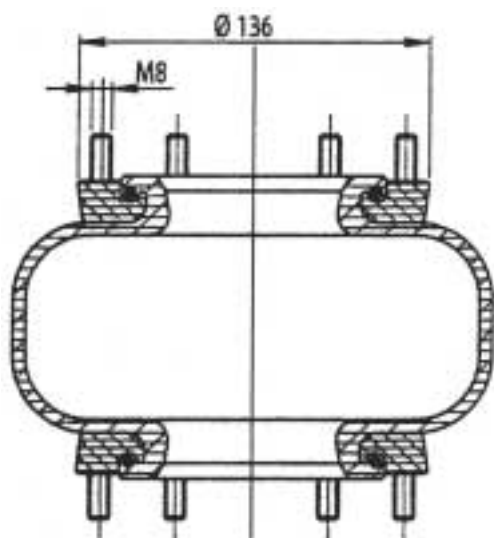

Vista dall'alto

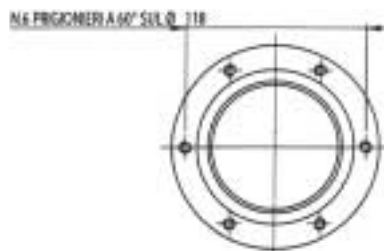

Vista dal basso

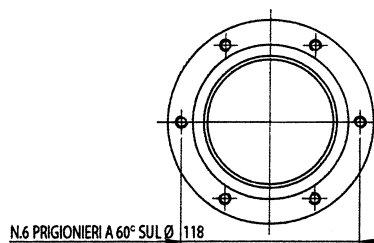

### Applicazioni principali

ASSALI SANSAVINI	F3034A
ASSALI STEFEN	19141000
AUSTERAS	99381001
BARTOLETTI	91621110
B.P.V. / BATTAGLINO	22.070.00
R.O.R. / MERITOR	21212549
TRAS CAR	03003000040
ZORZI	100 6508

### Lista corrispondenze

CONTITECH	
FIRESTONE	
PHOENIX	
TAURUS	
DUNLOP UK	
DUNLOP F	
GOODYEAR	
PIRELLI	
GART	T275 275.I.120



**MOLLE AD ARIA PER SEDILI**

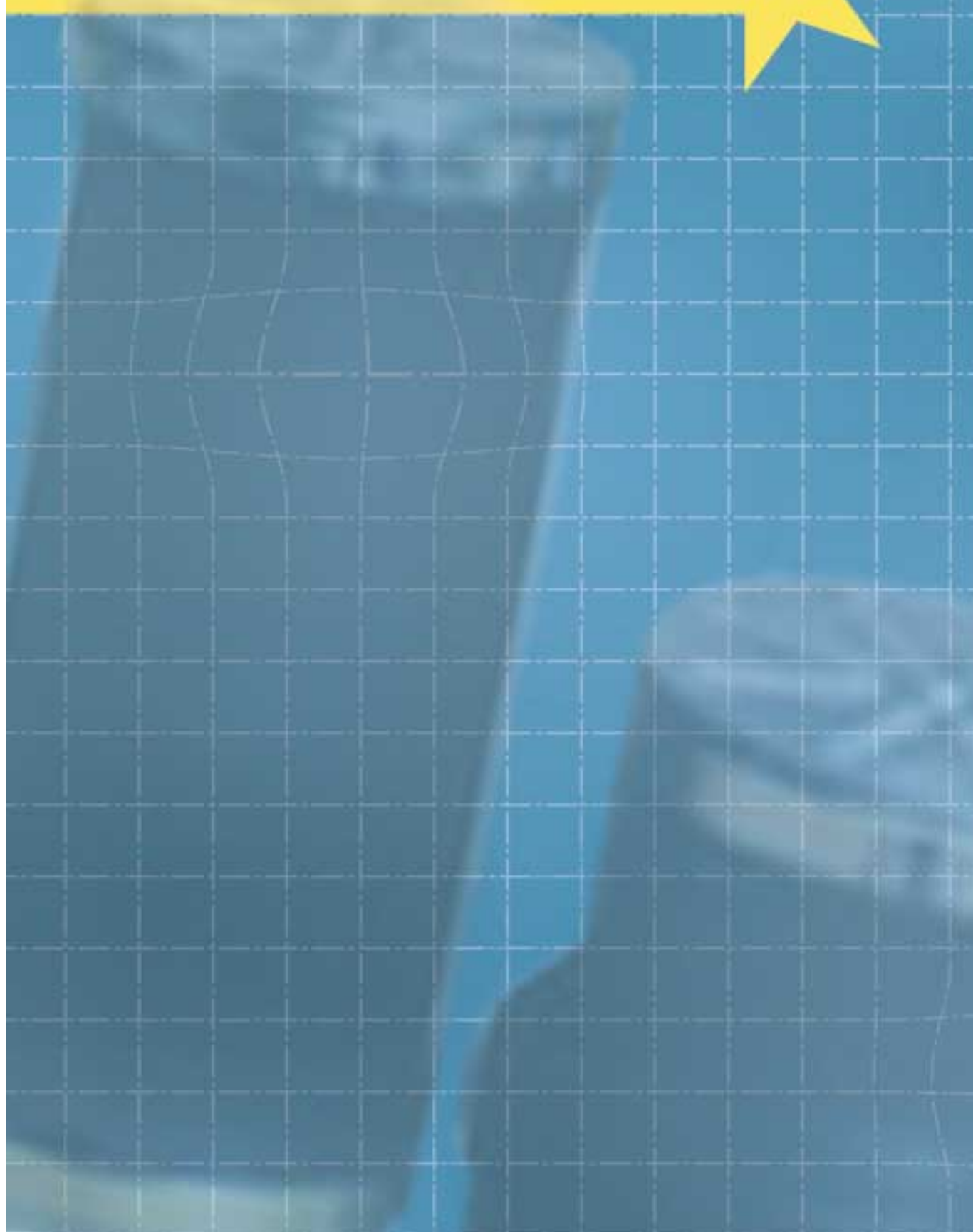



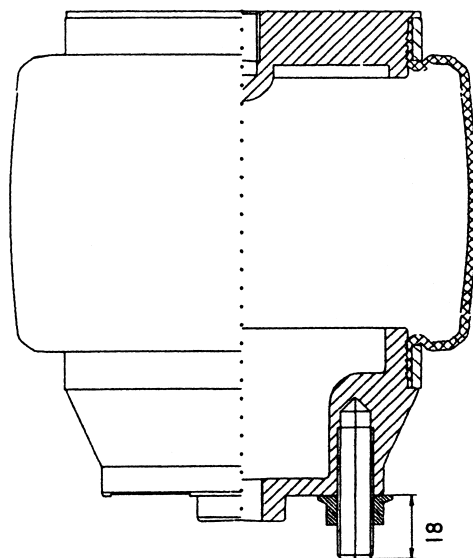

Vista dall'alto

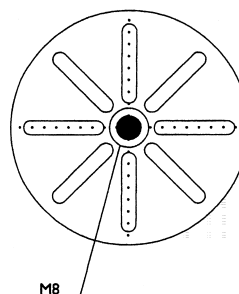

### Applicazioni principali



### Lista corrispondenze

CONTITECH	SZ 51-7
FIRESTONE	
PHOENIX	
TAURUS	
DUNLOP UK	
DUNLOP F	
GOODYEAR	
PIRELLI	
GART	

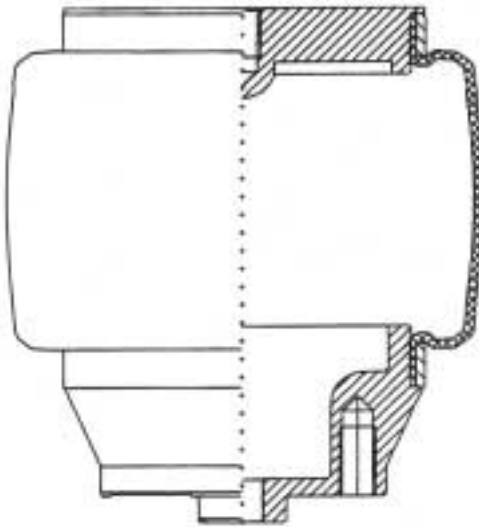

A520103

AIRTECH® 125102



Vista dall'alto

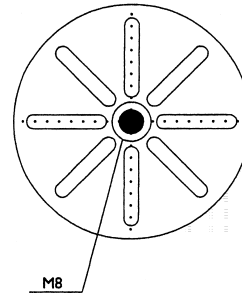

**Applicazioni principali**

ISRINGHAUSEN	3,1396

**Lista corrispondenze**

CONTITECH	864 Z / SZ 60-6
FIRESTONE	
PHOENIX	
TAURUS	
DUNLOP UK	
DUNLOP F	
GOODYEAR	
PIRELLI	
GART	



A520104

**AIRTECH®** 125103

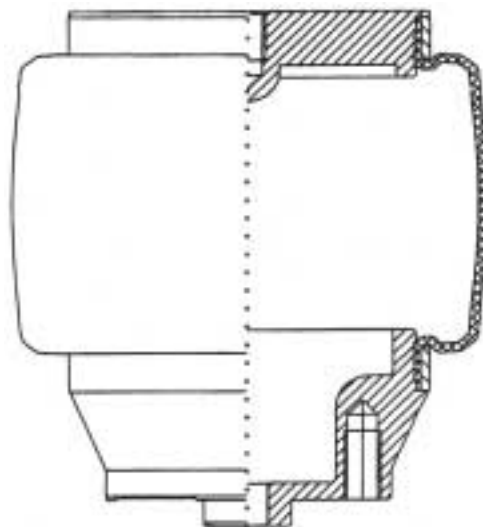

Vista dall'alto

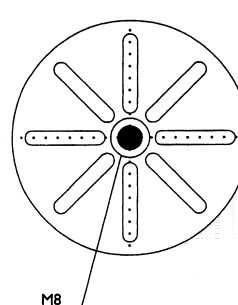

### Applicazioni principali

ISRINGHAUSEN	3,3207

### Lista corrispondenze

CONTITECH	SZ 62-7
FIRESTONE	
PHOENIX	
TAURUS	
DUNLOP UK	
DUNLOP F	
GOODYEAR	
PIRELLI	
GART	



A520105

AIRTECH® 125104

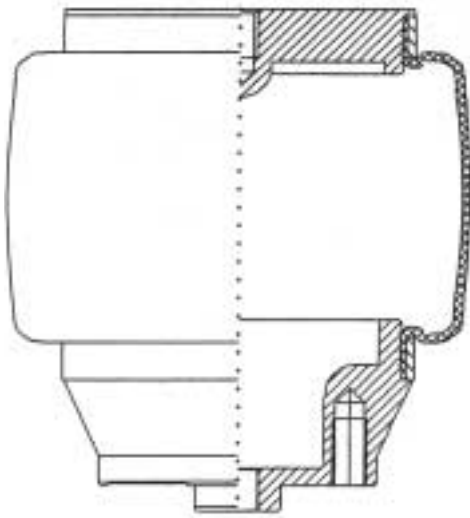

Vista dall'alto

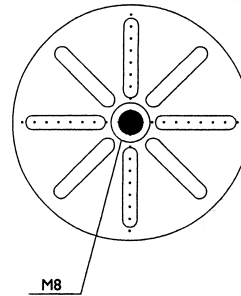

**Applicazioni principali**

ISRINGHAUSEN	3,1390

**Lista corrispondenze**

CONTITECH	865 Z / 937 N
FIRESTONE	
PHOENIX	
TAURUS	
DUNLOP UK	
DUNLOP F	
GOODYEAR	
PIRELLI	
GART	

# MOLLE AD ARIA PER SEDILI



A520138

**AIRTECH®** I2600I



Vista dall'alto

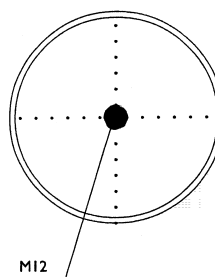

## Applicazioni principali

VOLVO	I081785

## Lista corrispondenze

CONTITECH	SK 95-26
FIRESTONE	
PHOENIX	
TAURUS	
DUNLOP UK	
DUNLOP F	
GOODYEAR	
PIRELLI	
GART	





# LISTA CORRISPONDENZE



# LISTA CORRISPONDENZE

da codice PIRELLI

AIRTECH	RNB	CF / PIRELLI		CONTITECH	FIRESTONE	
3813 K	A520070C	<b>I T 19 E-2</b>	<b>87408</b>	813 MB	IT 19 F-11	W01 M58 6364
3897	A520032	<b>I S 320 30</b>	<b>88788</b>	897 N	IRIK 440-320 FF	W01 095 0229
3720	A520044	<b>I SC 290-30</b>	<b>88802</b>	720 N	IR2A 460-295	W01 095 0195
3943	A520026	<b>I S 285-18</b>	<b>88809</b>	943 N	IRIA 260-285	W01 095 0189
3809 T		<b>I T 320 SP</b>	<b>89753</b>	809 NTB	IT 15 L-6	W01 M58 0687
3737	A520027	<b>I S 323-23</b>	<b>89756</b>	737 N	IR2A 480-330	W01 095 0211
3819	A520154	<b>I S 215-22</b>	<b>90609</b>	819 N		
3661	A520009	<b>I S 310-28</b>	<b>91016</b>	661 N	IRIC 390-310	W01 095 0021
3876	A520101	<b>I S 323-34</b>	<b>92477</b>	876 N		
3716	A520076	<b>I SC 300-34</b>	<b>92548</b>	716 N	IR2A 450-305	W01 095 0145
3644	A520002	<b>I S 285-24</b>	<b>92574</b>	644 N	IRIA 390-295	W01 095 0118
3727	A520084	<b>I SC 360-34</b>	<b>92575</b>	727 N	IR2D 460-360	W01 095 0191
3728	A520085	<b>I SC 360-34</b>	<b>92575</b>	728 N	IR2D 470-360	W01 095 0419
3719	A520083	<b>I SC 360-43</b>	<b>92593</b>	719 N	IR2D 530-360	W01 095 0192
3662	A520046	<b>I SC 360-30</b>	<b>92594</b>	662 N	IRID 355-355	W01 095 0207/0030
3762	A520048	<b>I SC 360-30</b>	<b>92594</b>	762 N	IR2D 390-360	W01 095 0190
3715	A520082	<b>I SC 310-16</b>	<b>93518</b>	715 N	IRIC 335-310	W01 095 0087
34810 T		<b>I T 19 E-1</b>	<b>93702</b>	810 NTB	IT 19 L-7	W01 M58 0749
320285	A520153	<b>I S 285-20</b>	<b>96534</b>			
391210 K	A520006C	<b>I T 323-40</b>	<b>96864</b>			
391209 K	A520023C	<b>I T 323-40</b>	<b>96871</b>		IT 15 M-9	W01 M58 6289
36884K	A520162C	<b>I T 19 E-1</b>	<b>96884</b>			
36885K	A520163C	<b>I T 19 E-2</b>	<b>96885</b>			
3882	A520039	<b>I SC 250-28</b>	<b>97042</b>	882 NI		
3884	A520086	<b>I SC 270-28</b>	<b>97043</b>	884 N		
34156 KPP	A520089C	<b>I T 323-32</b>	<b>97306</b>	4156 NP 06	IT 15 M-6	W01 358 9361
391210 K/I	A520006C/I	<b>I T 323-40 BG</b>	<b>97307</b>			
391303 K	A520012C	<b>I T 19 E-3</b>	<b>97393</b>		IT 19 L-12	W01 M58 7380/ 8765
3945	A520003	<b>I S 285-25 C</b>	<b>97555</b>	945 N	IRIA 460-290	W01 095 0063
3782	A520065	<b>I S 270-25 C</b>	<b>97608</b>	782 N	IRIA 415-285	W01 095 0197
3944	A520035	<b>I S 270-23</b>	<b>97619</b>	944 N	IRIA 390-270	W01 095 0121
34004 K	A520062C	<b>I T 323-33</b>	<b>97722</b>	4004 NP 03	IT 17 BS-6	W01 M58 6366
391318 K/I	A520021C/I	<b>I T 19 E-2</b>	<b>97730</b>			
34813 K	A520056C	<b>I T 19 E-2 BR</b>	<b>97764</b>	4813 N P07	IT 19 L-11	W01 S05 7358
34159-02 KPP	A520094C	<b>I T 323-40</b>	<b>200751</b>	4159 NP 06	IT 15 M-9	W01 379 9131
30076 K	A520147C	<b>I T 19 E-6</b>	<b>201715</b>			
391304 K	A520019C	<b>I T 19 E-3</b>	<b>201840</b>		IT 19 L-14	W01 M58 8762
3819	A520154	<b>I S 215-23</b>	<b>202189</b>	819 N		
34159-05 K	A520128C	<b>I T 323-40</b>	<b>202302</b>	4159 NP 07	IT 15 M-9	W01 M58 358 9191
3921		<b>I S 285-23</b>	<b>202728</b>	921 N	IRIA 415-260	W01 095 0226
320270	A520151	<b>I S 270-20V</b>	<b>202773</b>			
3725 P	A520067	<b>I TCS 360-45</b>	<b>202964</b>	725 NP 01	IT 66 E-10.8	W01 M58 8969
3415-25	A520050	<b>I S 280-25</b>	<b>203000</b>	RZ 415-25	IR5P 345-290	W01 095 0381
3415-28	A520051	<b>I S 280-28</b>	<b>203001</b>	RZ 415-28	IR5P 410-290	W01 095 0382
3450-25	A520052	<b>I S 300-27</b>	<b>203386</b>	RZ 450-25		
34004 KPP	A520090C	<b>I T 300-37</b>	<b>203715</b>	4004 NP 03	IT 17 BS6	W01 M58 6366
3811 K	A520081C	<b>I T 19 E-2</b>	<b>203878</b>	811 MB	IT 19 F-11	W01 M58 6334
391324 K		<b>I T 19 E-2</b>	<b>203878</b>	811 MB3	IT 19 F-11	W01 M58 6359/ 6334
34159-02 K	A520066C	<b>I T 323-40</b>	<b>204124</b>	4159 NP 06	IT 15 M-9	W01 M58 9130
391318 K	A520021C	<b>I T 19 E-2</b>	<b>204371</b>	811 MB	IT 19 L-11	W01 M58 6361
34420 K	A520164C	<b>I T 19 E-2</b>	<b>204420</b>			
323290	A520152	<b>I S 290-23V</b>	<b>204427</b>			
3941 P	A520028	<b>I TC 300-36</b>	<b>204466</b>	941 MB	IT 17 D-8.3	W01 M58 8620/8619
3881 P	A520029	<b>I TC 360-45</b>	<b>204530</b>	881 MB	IT 66 D-10.8	W01 M58 8978
34023 K	A520059C	<b>I T 19 E-2</b>	<b>204676</b>	4023 NP 03	IT 19 L-11	W01 M58 6348
3941 K	A520028C	<b>I TC 300-36</b>	<b>205170</b>	941 MB	IT 17D-8.3	W01 M58 8620/8619
32918 K	A520146C	<b>I T 19 E-1</b>	<b>205456</b>	4810 NP 05	IT 19 L-7	W01 M58 6338
3940 P	A520034	<b>I TC 300-30</b>	<b>205536</b>	940 MB	IT 17D-13	W01 M58 8613

# LISTA CORRISPONDENZE

da codice PIRELLI



	GART	PHOENIX	TAURUS	DUNLOP UK	SPRINGRIDE	GOODYEAR	Pag.
	D277 (4.500)	I D 28 B-2 E2	KR 622-26	PNP 31156/78	D 13 B19	I R 14-705	107
	D278 (0.430)	2 E 23	B 165	PNP 305210101	SP 2192	8028	61
		I F 21	B 152	PNP 301000100	D12S04	9008	41
	D276/D (0.260)		B 194	PNP 316720100		9001	67
		I D 23 C-1	UR 504-13			I R 12-709	91
		I F 26	B 127				44
	D296/C (0.360)						53
	D 297 (0.390)	I E 25	B 114	PNP 304980101	D12S02	8018	32
	D298/C (0.460)					8314	56
		I F 26 B-1	B 197				39
	D276/B (0.390)	I E 21	B 121	PNP 301470101	D11S01	8017	31
		I F 32 A	B 149	PNP 306420100		8117	42
		I F 32 A-2	B 149	PNP 306420100		8117	43
		I F 32 B-1	B 153	PNP 304620101		8118	40
		I E 32	B 143	PNP 302730101		9007	33
		I F 32	BL 143	PNP 307800100		9010	47
		I F 25	B 144	PNP 304890101		8015	38
						I R 14-713	202
	D276/E (0.330)						78
	D278/H (4.514)				D 13B06/10		248
	D278/H (2.512)				D 12 B18		247
	D277/B (2.421)						225
	D277 (2.503)						226
		I F 16	B 155				57
		I F 20 A	B 249			9002	59
	D 278/G (4.421)	I DK 21 A-2	KR 50-28		D12B16	I R 12-716	165
							249
	D287/B (4.580)	I D 28 H13			D 13 B 03		251
	D276 (0.420)	I E 21-C	B 124	PNP 301000101	D11S02	9014	69
	D290 (0.420)	I E 21-D	B 124			9013	50
	D290/B (0.390)					8012	68
		I DK 22 E-5	K 505-27SM		D12B13	I R 11-706	147
	D277/2F(2.504)						256
	D287 (4.520)	I D 28 B-9	KR 622-01		D13B10	I R 14-727	204
	D278/H (1.510)	I DK 21 B8	KR-509-25	PNP311370000	D12B02	I R 12-721	182
	D287/D (2.670)						137
					D13 B04		252
	D296/C (0.360)						53
	D278/H (2.511)	I DK 21 B-6	KR 509-9091		D 12 B 01/08	I R 12-702	186
	D276/BS (0.391)	I E 17	B 160		D10S04	8043	63
	D290E (0.340)						77
	C292-S (0.533)	I DF 32	UR 836- 11		D14 U38	I R 14-704	87
		2 G 20	B 271			9004	80
		2 G 20 A	B 272			9005	81
		I E 23	B 128				84
		I DK 22 E-8			D12B13	I R 11-713	148
	D277 (4.506)	I D 28 B-7	KR 622-31		D 13 B17	I R 14-718	95
					D 13 B24	I R 11-703	259
	D278/H (4.511)	I DK 21 B-2	KR-509-25	PNP311370000	D12B02	I R 12-701	181
	D277/2F(2.500)		K 622-26 SM	PNP 311670000	D13B18/12	I R 14-706	255
							194
							79
	C293 (0.511)	I DK 21	KR 730-01		D11 U30	I R 11-700	130
	C292 (0.531)	IDK 32-1	KR 836-01		D14 U36	I R 14-708	121
	D277 (4.505)	I D 28 B-10			D13B26	I R 14-729	155
	C293 (2.510)	I DK 21	UR 730-01		D11 B32	I R 11-702	131
	D277/B (4.423)					I R 14-730	144
	C293/A (0.411)	I DK 21 K	KR 732-01		D11 U31	I R 11-703	127

# LISTA CORRISPONDENZE

da codice PIRELLI

AIRTECH	RNB	CF / PIRELLI		CONTITECH	FIRESTONE	
34881 P	A520030	<b>ITC 360-40</b>	<b>205537</b>		IT 66D-7.0	W01 M58 8601
39002-A3 K	A520036C	<b>ITC 300-38</b>	<b>205598</b>	4157 NP 05	IT 15 MPW-7	W01 M58 7074
3881-01 K	A520029C	<b>ITC 360-45</b>	<b>205800</b>	881 MB	IT 66 D-10.8	W01 M58 8978/8966
34913 K	A520045C	<b>IT 19 E-93</b>	<b>206201</b>	4913 NP 02	IT 19 F-14	W01 095 0366
34913 P	A520045	<b>IT 19 E-93</b>	<b>206201</b>	4913 NP 02	IT 19 F-14	W01 095 0366
32926 K	A520132C	<b>IT 19 E-2L</b>	<b>206333</b>			
34022 KPP	A520095C	<b>IT 300-37</b>	<b>206340</b>	4022 NP 03	IT 17 BS6	W01 M58 6366
3941 KPP	A520088C	<b>ITC 300-36</b>	<b>206356</b>	941 MB	IT 17 D-8.3	W01 M58 8620/8619
3881-01 KPP	A520087C	<b>ITC 360-45</b>	<b>206357</b>	881 MB	IT 66 D-10.8	W01 M58 8978/8966
32619 KPP	A520131C	<b>IT 300-37</b>	<b>206585</b>		IT 17 BS-6	W01 M58 8612
34912 K	A520060C	<b>IT 19 E-4</b>	<b>206779</b>	4912 NP 07		
34912 P	A520060	<b>IT 19 E-4</b>	<b>206780</b>	4912 NP 08		
34390-01 P	A520093	<b>IVSC 285-30</b>	<b>206782</b>	4390 NI		
34390-02 P				4390 NP 02		
3836-02 K	A520069C			836 M2 K I	IT-17 AR4,5	
34004 P	A520062	<b>IT 300-37</b>		4004 NP 02	IT 17 BS-6	
39002-A8 KPP	A520037C	<b>IT 300-40</b>		4158 NP 04	IT 15 MPW7	W01 M58 6297
3810 K	A520010C	<b>IT 19 E-1</b>	<b>87413/I</b>	810 MB	IT 19 L-7	W01 M58 6345/ 8775
391320 K	A520049C	<b>IT 19 E-1</b>	<b>87413/I</b>	810 MB	IT 19 L-7	W01 M58 6345/ 7337
3836-02 P	A520040			836 M2	IT-17 AR4,5	W01 D08 0777
34023 P		<b>IT 19 E-2</b>		4023 N	IT 19 L-11	W01 M58 6335
3811 P		<b>IT 19 E-2</b>		811 M16	IT 19 F-11	W01 M58 6333
3813-03 K		<b>IT 19 E-2</b>		813 MB		
34813 P		<b>IT 19 E-2 BR</b>		4813 NP 07	IT 19 L-11	
3912 K		<b>IT 19 E-4</b>		912 MB	IT 19 L-14	W01 M58 7385
34156 P	A520080	<b>IT 323-32</b>		4156 NP 01	IT 15 M-6	
34159 K		<b>IT 323-40</b>		4159 NP 05	IT 15 M-9	
34159 P	A520117	<b>IT 323-40</b>		4159 NP 05	IT 15 M-9	
39002-A3		<b>ITC 300-38</b>		4157 NP 05	IT 15 MPW-7	W01 M58 7074
34881-01 K	A520030C	<b>ITC 360-45</b>		4881 MB	IT 66D-7.0	W01 M58 8601
3673	A520042			673 N		
3701	A520122			701 N	IR3M 340-340	W01 095 0205
3706				706 N		
3713	A520064			713 N		
3746				746 N		
3757	A520077			757 N	IR2A 380-305	W01 095 0212
3768	A520043			768 N	IR2A 370-285	W01 095 0198
3769	A520099			769 N	IR1A 380-260	W01 095 0204
3786	A520038			786 N		
3788				788 N		
3838	A520111			838 N		
3873				873 N		
3883	A520096			883 NI		
3896	A520118			896 N	IRIJ 520-285 FF	W01 095 0245
3916	A520097			916 NI		
3927	A520033			927 N	IR IK 380 280	W01 095 0244
3928	A520078			928 N	IRIK 380-320 FF	W01 095 0228
3936	A520150			936 N		
31234	A520116			1234 N		
31277	A520124				IR4U 395260	W01 095 0453
31421	A520092			1421 N		
31720				1720 N		
31774				1774 N		
31885	A520031			1885 NI	IR2A445 280	W01 095 0429
31924				1924 NI		
34940	A520053			4940 NP 02		
34941	A520054			4941 NP 02		
34960	A520047			4960 NP 02		

# LISTA CORRISPONDENZE

da codice PIRELLI



	GART	PHOENIX	TAURUS	DUNLOP UK	SPRINGRIDE	GOODYEAR	Pag.
	C292/A (0.461)	I DK 32 K					206
	C294 (2.450)	I DK 21 A3	KR 915-54		D 12 B17	I R 11-106	232
	C292 (2.531)	IDK 32-I	UR 836-01		D14 B36	I R 14-703	122
	C282/H (1.600)	I D 28 H16	KR 625-16			I R 14-753	214
							213
						I R 14-728	145
		I DK 22 E-9			D12B14	I R 11-714	151
			KR 730-01		D11 U30		132
	C292 (2.530)		KR 836-01		D14 B36	I R 14-703	123
							143
						I R 13-711	212
							211
							190
							192
		I DF 25 I3	KR 721-03		D13 B31	I R 12-710	117
						I R 11-705	118
	C294 (2.451)	I DK 21 A8/4			D 12 B18	I R 11-111	235
	D277/B (4.420)	I D 28A-2	k 621 26	PNP 311670000	D 13 B20	I R 14-716	93
	D277/B (4.420)		B 104/K 104	PNP 311780000	D13B01/20	I R 14-059	257
		I DF 25 3			D13 U31	I R 12-710	116
							154
					SP 2066	I R 14-718	94
							110
	D287 (4.520)	I D 28 B-9	KR 622-01		D13B10	I R 14-727	203
					D13 B14		126
							164
	D278/H	I DK 21 B5-B2	K-509-22		D12B08	I R 12-701	180
						I R 12-761	179
		I DK 21 A3			D 12 B17	I R 11-106	231
	C292/A (2.460)	I DK 32 K	UR 837 01		D14U37/D14B37	I R 14-701	207
		I F 21 A	B 141				34
		I E 26-I	B 116-I			9006	35
							36
							37
							45
		I F 26 C	B 126				46
		I E 27	B 125				48
		I E 18	B 156	PNP 301470101	D10S02	8053	49
		I F 14	B 102				51
			B 155				52
		I F 26 D					54
							55
		I F 21 C2				9012	58
		2 E 18A	B 166	PNP 305140100		8040	60
		I F 21 C-5	B 154		D12S05	9015	62
		2 E 18 B	B 179	PNP 300080100		8037	64
		2 E 23 A	B 178	IC 3308	D12S03	8042	65
				PNP 309070100	D12S01		66
							70
				PNP 31095			71
							72
							73
							74
		I F 20 B-I				9003	75
							76
							217
							218
							220

# LISTA CORRISPONDENZE

da codice PIRELLI

AIRTECH	RNB	CF / PIRELLI	CONTITECH	FIRESTONE	
3496 I	A520071		496 I NP 02		
3900 I					
3008 I K				I T 17 B 1 I	W0 I M58 8747
3008 I-0 I K				I T 15 VLT-10.5	W0 I 358 9580
30743 K					
32145 K					
32618 K					
34022 K	A520055C		4022 NP 03	I T 17 BS-6	W0 I M58 6367
34022 P	A520055		4022 NP 02	I T 17 BS-6	W0 I M58 0756
34022-0 I K					
34022-0 I P					
34028 P			4028 N		
34150 T			4150 NP 0 I	I T 15 M-0	
3415-25 2L					
3415-28 2L					
34154 KPP	A520057C		4154 NP 05		
34154-02 K				I T 15 M-4	W0 I 358 9010
34154-03 K				I T 15 M-4	W0 I D08 9056
34154-04 K				I T 15 M-4	W0 I S05 7283
34154-05 K				I T 15 M-4	W0 I 358 9069
34156 T					
34156-0 I K				I T 15 M-6	W0 I 358 8929
34156-02 K				I T 15 M-6	W0 I M58 9229
34156-02 P			4156 NP 05	I T 15 M-6	w0 I 352 0712
34156-03 K	A520173C			I T 15 M-6	W0 I 379 9089
34156-05 K				I T 15 M-6	W0 I 358 9082
34156-07 K				I T 15 M-6	W0 I 358 8929
34156-08 K				I T 15 M-6	W0 I 358 936 I
34156-09 K				I T 15 M-6	W0 I 358 9096
34156-10 K				I T 15 M-6	W0 I 379 9207
34156-1 I K				I T 15 M-6	W0 I F79 7349
34157 KP	A520133C		4157 NP 04	I T 15 MPW-7	W0 I M58 6297
34158- KPP	A52009 I C		4158 NP 03	I T 15 MPW9	W0 I M58 8185
34158 P			4158 NP 02	I T 15 MPW-7	
34159-03 K				I T 15 M-9	
34159-03 P					
34159-04 K				I T 15 M-9	W0 I M58 9222
34159-07 K					
34159-08 K				I T 15 M-9	W0 I 358 9192
34159-09 K				I T 15 M-9	W0 I 358 9104
34390-0 I K	A520093C		4390 NP 0 I		
34390-02 K	A520098C		4390 NP 02		
34713 K	A520072C		4713 NP 02		
34713 P	A520072		4713 N		
34718 K	A52012 I C		4718 N		
34737-0 I K			4737 NP 0 I		
34737-02 K			4737 NP 02		
34757-0 I K			4757 NP 0 I		
34757-02 K			4757 NP 02		
34838 P	A520126		4838 NP 03		
34881-0 I KPP	A520130C				
3491 I K	A520075C		491 I NP 02		
3491 I P	A520075		491 I N		
34915 P	A5201 I 2		4915 NP 03		
34925 K	A520120C		4925 N		
3494 I K	A520054C		494 I NP 02		
361420 K	A520149C				
36142 I K	A520144C				

# LISTA CORRISPONDENZE

da codice PIRELLI



	GART	PHOENIX	TAURUS	DUNLOP UK	SPRINGRIDE	GOODYEAR	Pag.
							221
							229
						I R 13-150	138
						I R 13-118	139
							140
							141
							142
			KR 725-28		D13B25	I R 11-710	150
						I R 11-709	149
							153
							152
							156
						I R 12 - 097	157
							82
							83
							158
							159
							160
							161
						I R 12-069	162
							163
							166
		I DK 21 A-2					168
			KR 506-28		D12B16	I R 12-706	167
						I R 12-092	169
						I R 12-461	170
						I R 12-716	171
							172
							173
							174
							175
			KR 915-52				176
	D278HS (1.530)	I DK 20 A-I I DK 20 B-I				I R 12-749	178
							177
							184
				PNP 31 1370000	D12B08		183
							185
						I R 12-103	187
						I R 12-167	188
							189
							191
							193
						I R12 -762	196
							195
							197
							198
							199
							200
							201
							205
							208
							210
							209
							215
							216
							218
	D276/R (1.420)						238
	D276/R (1.421)						239

# LISTA CORRISPONDENZE

da codice PIRELLI

AIRTECH	RNB	CF / PIRELLI	CONTITECH	FIRESTONE	
361480 K	A520148C				
361481 K	A520145C				
36199 K	A520140C				
36200 K	A520139C				
362421 K	A520167C				
3638-06 K			836 MBK6		
36416 K	A520175C				
3725 K			725 NP 02	IT 66 E-10.8	W01 M58 8969
3725-01 K	A520125C		725 NP 03		
374521 K	A520166C				
37803 P					
3808 T			808 NT		
3810 P			810	IT 15 L-7	W01 M58 0491/ 0749
3811-01 K			811 MB		
3811-01 P			811 MB	IT 19 F-11	
3811-02 K	A520174C				
3811-02 P			811	IT 19 L-11	
3811-03 P			811 MB3	IT 19 F-11	W01 M58 6359
3811-04 P					
3811-05 P					
3811-06 K			811 MB		
3811-06 P			811 MB3	IT 19 F-11	W01 M58 6359
3811-07 K			810 M16 KI	IT 19 F-11	W01 M58 6334
3813 P	A520070		813 MB 0	IT 19 L-11	
3813-01 K			813 MB		
3813-01 P			813 MB		
3813-03 K	A520169C				
3813-05 K				IT 19 L-11	W01 358 9122
3813-06 K			813 MB		
38186KPP	A520165C		4157 NP 06	IT 15 MPW-7	W01 968 8186
382430 K	A520142C				
382520 K	A520143C				
3836 K	A520061C		836 MK 1		
3836 P	A520061		836 M		
3836-01 P	A520041		836 MB	IT-17 AR4,5	W01 D08 0776
3836-04 K			836 MBK4		
3836-07 K			836 MK7	IT 17AR-4,5	D08 8715
3897 K					
39001 K					
39002-A3-01 K	A520127C			IT 15MPW-7	W01 379 6315
39002-A8			4157 NP 04	IT 15 MPW7	W01 M58 6297
3909 T			909 NT	IT 15 L-6	W01 M58 0031
391208 K	A520024C			IT 15 M-9	W01 M58 8859/ 9091
391208 K				IT 15 M-9	W01 M58 8859 / 3799091
391210-01K	A520168C				
391305 K					
391314 K	A520020C		912 MB	IT 19 L-14	W01 M58 7385/ 8766
391323 K	A520074C				
3940 K	A520034C		940 MB	IT 17D-6.5	
3940 KPP	A520129C		940 MB		
3942 P	A520068		942 MB		
3942-01 K	A520068C		942 MB		
3944 K			944 N		
3951 P	A520063		951 MB	IT 17 D-11.8	W01 M58 8621
39780 K	A520172C				
	A520170C				



# LISTA CORRISPONDENZE

da codice PIRELLI



	GART	PHOENIX	TAURUS	DUNLOP UK	SPRINGRIDE	GOODYEAR	Pag.
	D276/LR (1.480)						240
	D276/LR (1.481)						241
							222
							223
	D276/R-2F (2.42)						242
							0
		I DF 32	UR 836-11			I R 14-704	224
						I R 14-747	88
	D277/DA (4.521)						89
							243
		I D 23 A-1	UR 500-13				227
		I D 28 A		PNP 307320000			90
							92
			K 622-26 SM	PNP 311670000			97
	D287 (4.522)					I R 14-719	96
			KR 622-31				99
							98
							100
							101
							102
							104
							103
					D13B24	I R 14-719	105
							106
							109
	D277/D (4.520)				D13 U32		108
							111
		I DK 20 A-1					112
	D278/E (2.430)						228
	D278/F (2.520)						244
		I DF 25 11	KR 721-06		D13 B32	I R 12-712	245
		I DF 25 1	KR 721		D 13 U32	I R 12-700	114
		I DF 25 1	721-01		D 13 U32	I R 12-700	113
							115
			KR 721-01		D 13 B33	I R 12-723	118
							120
							124
			KR 915-51				230
							233
		I DK 21 A8/4			D 12 B18	I R 11-111	234
		I D23 B2	B 151				125
			KR 509-9091		D 12 B07/09		246
			KR 509-9091		D12B08/01		246
	D278/H (4.512)						250
					D 13 B05		253
		I D 28 D-2			D 13 B14		254
					D 13 B23		258
	C293/A (0.411)	I DK 21 K	UR 732-01		D11 U31	I R 11-763	128
			KR 732-01		D11 U31	I R 11-763	129
			UR 837-01			I R 14-700	133
		BPW 35-1	UR 837-01				134
							135
						I R 11-704	136
	D277/DA (4.523)						237

# LISTA CORRISPONDENZE

da codice RNB

AIRTECH	RNB	CF / PIRELLI		CONTITECH	FIRESTONE	
3644	A520002	I S 285-24	92574	644 N	IRIA 390-295	W01 095 0118
3945	A520003	I S 285-25 C	97555	945 N	IRIA 460-290	W01 095 0063
391210 K	A520006C	I T 323-40	96864			
391210 K/I	A520006C/I	I T 323-40 BG	97307			
3661	A520009	I S 310-28	91016	661 N	IRIC 390-310	W01 095 0021
3810 K	A520010C	I T 19 E-1	87413/1	810 MB	IT 19 L-7	W01 M58 6345/ 8775
391303 K	A520012C	IT 19 E-3	97393		IT 19 L-12	W01 M58 7380/ 8765
391304 K	A520019C	IT 19 E-3	201840		IT 19 L-14	W01 M58 8762
391314 K	A520020C			912 MB	IT 19 L-14	W01 M58 8785/ 8766
391318 K	A520021C	I T 19 E-2	204371	811 MB	IT 19 L-11	W01 M58 6361
391318 K/I	A520021C/I	I T 19 E-2	97730			
391209 K	A520023C	I T 323-40	96871		IT 15 M-9	W01 M58 6289
391208 K	A520024C				IT 15 M-9	W01 M58 8859/ 9091
3943	A520026	I S 285-18	88809	943 N	IRIA 260-285	W01 095 0189
3737	A520027	I S 323-23	89756	737 N	IR2A 480-330	W01 095 0211
3941 P	A520028	I TC 300-36	204466	941 MB	IT 17 D-8.3	W01 M58 8620/8619
3941 K	A520028C	I TC 300-36	205170	941 MB	IT 17D-8.3	W01 M58 8620/8619
3881 P	A520029	I TC 360-45	204530	881 MB	IT 66 D-10.8	W01 M58 8978
3881-01 K	A520029C	I TC 360-45	205800	881 MB	IT 66 D-10.8	W01 M58 8978/8966
34881 P	A520030	I TC 360-40	205537		IT 66D-7.0	W01 M58 8601
34881-01 K	A520030C	I TC 360-45		4881 MB	IT 66D-7.0	W01 M58 8601
31885	A520031			1885 NI	IR2A445 280	W01 095 0429
3897	A520032	I S 320 30	88788	897 N	IRIK 440-320 FF	W01 095 0229
3927	A520033			927 N	IR IK 380 280	W01 095 0244
3940 P	A520034	I TC 300-30	205536	940 MB	IT 17D-13	W01 M58 8613
3940 K	A520034C			940 MB	IT 17D-6.5	
3944	A520035	I S 270-23	97619	944 N	IRIA 390-270	W01 095 0121
39002-A3 K	A520036C	I TC 300-38	205598	4157 NP 05	IT 15 MPW-7	W01 M58 7074
39002-A8 KPP	A520037C	I T 300-40		4158 NP 04	IT 15 MPW7	W01 M58 6297
3786	A520038			786 N		
3882	A520039	I SC 250-28	97042	882 NI		
3836-02 P	A520040			836 M2	IT-17 AR4,5	W01 D08 0777
3836-01 P	A520041			836 MB	IT-17 AR4,5	W01 D08 0776
3673	A520042			673 N		
3768	A520043			768 N	IR2A 370-285	W01 095 0198
3720	A520044	I SC 290-30	88802	720 N	IR2A 460-295	W01 095 0195
34913 P	A520045	I T 19 E-93	206201	4913 NP 02	IT 19 F-14	W01 095 0366
34913 K	A520045C	I T 19 E-93	206201	4913 NP 02	IT 19 F-14	W01 095 0366
3662	A520046	I SC 360-30	92594	662 N	IRID 355-355	W01 095 0207/0030
34960	A520047			4960 NP 02		
3762	A520048	I SC 360-30	92594	762 N	IR2D 390-360	W01 095 0190
391320 K	A520049C	I T 19 E-1	87413/1	810 MB	IT 19 L-7	W01 M58 6345/ 7337
3415-25	A520050	I S 280-25	203000	RZ 415-25	IR5P 345-290	W01 095 0381
3415-28	A520051	I S 280-28	203001	RZ 415-28	IR5P 410-290	W01 095 0382
3450-25	A520052	I S 300-27	203386	RZ 450-25		
34940	A520053			4940 NP 02		
34941	A520054			4941 NP 02		
34941 K	A520054C			4941 NP 02		
34022 P	A520055			4022 NP 02	IT 17 BS-6	W01 M58 0756
34022 K	A520055C			4022 NP 03	IT 17 BS-6	W01 M58 6367
34813 K	A520056C	I T 19 E-2 BR	97764	4813 N P07	IT 19 L-11	W01 S05 7358
34154 KPP	A520057C			4154 NP 05		
34023 K	A520059C	I T 19 E-2	204676	4023 NP 03	IT 19 L-11	W01 M58 6348
34912 P	A520060	I T 19 E-4	206780	4912 NP 08		
34912 K	A520060C	I T 19 E-4	206779	4912 NP 07		
3836 P	A520061			836 M		
3836 K	A520061C			836 MK I		
34004 P	A520062	I T 300-37		4004 NP 02	IT 17 BS-6	

# LISTA CORRISPONDENZE

da codice RNB



	GART	PHOENIX	TAURUS	DUNLOP UK	SPRINGRIDE	GOODYEAR	Pag.
	D276/B (0.390)	I E 21	B 121	PNP 301470101	D11S01	8017	31
	D276 (0.420)	I E 21-C	B 124	PNP 301000101	D11S02	9014	69
	D278/H (4.514)				D 13B06/10		248
							249
	D 297 (0.390)	I E 25	B 114	PNP 304980101	D12S02	8018	32
	D277/B (4.420)	I D 28A-2	k 621 26	PNP 311670000	D 13 B20	I R 14-716	93
	D287/B (4.580)	I D 28 H13			D 13 B 03		251
					D13 B04		252
		I D 28 D-2			D 13 B14		254
	D277/2F(2.500)		K 622-26 SM	PNP 311670000	D13B18/12	I R 14-706	255
	D277/2F(2.504)						256
	D278/H (2.512)				D 12 B18		247
			KR 509-909I		D 12 B07/09		246
	D276/D (0.260)		B 194	PNP 316720100		9001	67
		I F 26	B 127				44
	C293 (0.511)	I DK 21	KR 730-01		D11 U30	I R 11-700	130
	C293 (2.510)	I DK 21	UR 730-01		D11 B32	I R 11-702	131
	C292 (0.531)	IDK 32-I	KR 836-01		D14 U36	I R 14-708	121
	C292 (2.531)	IDK 32-I	UR 836-01		D14 B36	I R 14-703	122
	C292/A (0.461)	I DK 32 K					206
	C292/A (2.460)	I DK 32 K	UR 837 01		D14U37/D14B37	I R 14-701	207
		I F 20 B-I				9003	75
	D278 (0.430)	2 E 23	B 165	PNP 305210101	SP 2192	8028	61
		2 E 18 B	B 179	PNP 300080100		8037	64
	C293/A (0.411)	I DK 21 K	KR 732-01		D11 U31	I R 11-703	127
	C293/A (0.411)	I DK 21 K	UR 732-01		D11 U31	I R 11-763	128
	D290/B (0.390)					8012	68
	C294 (2.450)	I DK 21 A3	KR 915-54		D 12 B17	I R 11-106	232
	C294 (2.451)	I DK 21 A8/4			D 12 B18	I R 11-111	235
		I F 14	B 102				51
		I F 16	B 155				57
		I DF 25 3			D13 U31	I R 12-710	116
		I DF 25 I	721-01		D 13 U32	I R 12-700	115
		I F 21 A	B 141				34
		I E 27	B 125				48
		I F 21	B 152	PNP 301000100	D12S04	9008	41
							213
	C282/H (1.600)	I D 28 H16	KR 625-16			I R 14-753	214
		I E 32	B 143	PNP 302730101		9007	33
							220
		I F 32	BL 143	PNP 307800100		9010	47
	D277/B (4.420)		B 104/K 104	PNP 311780000	D13B01/20	I R 14-059	257
		2 G 20	B 271			9004	80
		2 G 20A	B 272			9005	81
		I E 23	B 128				84
							217
							218
							218
			KR 725-28		D13B25	I R 11-709	149
	D287 (4.520)	I D 28 B-9	KR 622-01		D13B10	I R 11-710	150
						I R 14-727	204
							158
	D277 (4.505)	I D 28 B-10			D13B26	I R 14-729	155
							211
							212
		I DF 25 I	KR 721		D 13 U32	I R 13-711	212
		I DF 25 II	KR 721-06		D13 B32	I R 12-700	113
						I R 12-712	114
						I R 11-705	118

# LISTA CORRISPONDENZE

da codice RNB

AIRTECH	RNB	CF / PIRELLI		CONTITECH	FIRESTONE	
34004 K	<b>A520062C</b>	I T 323-33	97722	4004 NP 03	IT 17 BS-6	W01 M58 6366
3951 P	<b>A520063</b>			951 MB	IT 17 D-11.8	W01 M58 8621
3713	<b>A520064</b>			713 N		
3782	<b>A520065</b>	I S 270-25 C	97608	782 N	IRIA 415-285	W01 095 0197
34159-02 K	<b>A520066C</b>	I T 323-40	204124	4159 NP 06	IT 15 M-9	W01 M58 9130
3725 P	<b>A520067</b>	I TCS 360-45	202964	725 NP 01	IT 66 E-10.8	W01 M58 8969
3942 P	<b>A520068</b>			942 MB		
3942-01 K	<b>A520068C</b>			942 MB		
3836-02 K	<b>A520069C</b>			836 M2 K I	IT-17 AR4,5	
3813 P	<b>A520070</b>			813 MB 0	IT 19 L-11	
3813 K	<b>A520070C</b>	I T 19 E-2	87408	813 MB	IT 19 F-11	W01 M58 6364
34961	<b>A520071</b>			4961 NP 02		
34713 P	<b>A520072</b>			4713 N		
34713 K	<b>A520072C</b>			4713 NP 02		
391323 K	<b>A520074C</b>					
34911 P	<b>A520075</b>			4911 N		
34911 K	<b>A520075C</b>			4911 NP 02		
3716	<b>A520076</b>	I SC 300-34	92548	716 N	IR2A 450-305	W01 095 0145
3757	<b>A520077</b>			757 N	IR2A 380-305	W01 095 0212
3928	<b>A520078</b>			928 N	IRIK 380-320 FF	W01 095 0228
34156 P	<b>A520080</b>	I T 323-32		4156 NP 01	IT 15 M-6	
3811 K	<b>A520081C</b>	I T 19 E-2	203878	811 MB	IT 19 F-11	W01 M58 6334
3715	<b>A520082</b>	I SC 310-16	93518	715 N	IRIC 335-310	W01 095 0087
3719	<b>A520083</b>	I SC 360-43	92593	719 N	IR2D 530-360	W01 095 0192
3727	<b>A520084</b>	I SC 360-34	92575	727 N	IR2D 460-360	W01 095 0191
3728	<b>A520085</b>	I SC 360-34	92575	728 N	IR2D 470-360	W01 095 0419
3884	<b>A520086</b>	I SC 270-28	97043	884 N		
3881-01 KPP	<b>A520087C</b>	I TC 360-45	206357	881 MB	IT 66 D-10.8	W01 M58 8978/8966
3941 KPP	<b>A520088C</b>	I TC 300-36	206356	941 MB	IT 17 D-8.3	W01 M58 8620/8619
34156 KPP	<b>A520089C</b>	I T 323-32	97306	4156 NP 06	IT 15 M-6	W01 358 9361
34004 KPP	<b>A520090C</b>	I T 300-37	203715	4004 NP 03	I T 17 BS6	W01 M58 6366
34158- KPP	<b>A520091C</b>			4158 NP 03	I T 15 MPW9	W01 M58 8185
31421	<b>A520092</b>			1421 N		
34390-01 P	<b>A520093</b>	I VSC 285-30	206782	4390 NI		
34390-01 K	<b>A520093C</b>			4390 NP 01		
34159-02 KPP	<b>A520094C</b>	I T 323-40	200751	4159 NP 06	IT 15 M-9	W01 379 9131
34022 KPP	<b>A520095C</b>	I T 300-37	206340	4022 NP 03	I T 17 BS6	W01 M58 6366
3883	<b>A520096</b>			883 NI		
3916	<b>A520097</b>			916 NI		
34390-02 K	<b>A520098C</b>			4390 NP 02		
3769	<b>A520099</b>			769 N	IRIA 380-260	W01 095 0204
3876	<b>A520101</b>	I S 323-34	92477	876 N		
3838	<b>A520111</b>			838 N		
34915 P	<b>A520112</b>			4915 NP 03		
31234	<b>A520116</b>			1234 N		
34159 P	<b>A520117</b>	I T 323-40		4159 NP 05	IT 15 M-9	
3896	<b>A520118</b>			896 N	IRIJ 520-285 FF	W01 095 0245
34925 K	<b>A520120C</b>			4925 N		
34718 K	<b>A520121C</b>			4718 N		
3701	<b>A520122</b>			701 N	IR3M 340-340	W01 095 0205
31277	<b>A520124</b>				IR4U 395260	W01 095 0453
3725-01 K	<b>A520125C</b>			725 NP 03		
34838 P	<b>A520126</b>			4838 NP 03		
39002-A3-01 K	<b>A520127C</b>				IT 15MPW-7	W01 379 6315
34159-05 K	<b>A520128C</b>	I T 323-40	202302	4159 NP 07	I T 15 M-9	W01 M58 358 9191
3940 KPP	<b>A520129C</b>			940 MB		
34881-01 KPP	<b>A520130C</b>					
32619 KPP	<b>A520131C</b>	I T 300-37	206585		IT 17 BS-6	W01 M58 8612

# LISTA CORRISPONDENZE

da codice RNB



	GART	PHOENIX	TAURUS	DUNLOP UK	SPRINGRIDE	GOODYEAR	Pag.
		I DK 22 E-5	K 505-27SM		D12B13	I R 11-706	147
						I R 11-704	136
							37
	D290 (0.420)	I E 21-D	B 124			9013	50
	D278/H (4.511)	I DK 21 B-2	KR-509-25	PNP311370000	D12B02	I R 12-701	181
	C292-S (0.533)	I DF 32	UR 836- 11		D14 U38	I R 14-704	87
			UR 837-01			I R 14-700	133
		BPW 35-1	UR 837-01				134
		I DF 25 13	KR 721-03		D13 B31	I R 12-710	117
							106
	D277 (4.500)	I D 28 B-2 E2	KR 622-26	PNP 31156/78	D 13 B19	I R 14-705	107
							221
							195
						I R12 -762	196
					D 13 B23		258
							209
							210
		I F 26 B-1	B 197				39
		I F 26 C	B 126				46
		2 E 23 A	B 178	IC 3308	D12S03	8042	65
							164
	D277 (4.506)	I D 28 B-7	KR 622-31		D 13 B17	I R 14-718	95
		I F 25	B 144	PNP 304890101		8015	38
		I F 32 B-1	B 153	PNP 304620101		8118	40
		I F 32 A	B 149	PNP 306420100		8117	42
		I F 32 A-2	B 149	PNP 306420100		8117	43
		I F 20 A	B 249			9002	59
	C292 (2.530)		KR 836-01		D14 B36	I R 14-703	123
			KR 730-01		D11 U30		132
	D 278/G (4.421)	I DK 21 A-2	KR 50-28		D12B16	I R 12-716	165
		I DK 22 E-8			D12B13	I R 11-713	148
	D278HS (1.530)	I DK 20 B-1				I R 12-749	178
							72
							190
							191
	D278/H (1.510)	I DK 21 B8	KR-509-25	PNP311370000	D12B02	I R 12-721	182
		I DK 22 E-9			D12B14	I R 11-714	151
		I F 21 C2				9012	58
		I F 21 C-5	B 154		D12S05	9015	62
							193
		I E 18	B 156	PNP 301470101	D10S02	8053	49
	D298/C (0.460)					8314	56
		I F 26 D					54
							215
							70
						I R 12-761	179
		2 E 18 A	B 166	PNP 305140100		8040	60
							216
							197
		I E 26-1	B 116-1			9006	35
				PNP 31095			71
							89
							205
			KR 915-51				233
	D278/H (2.511)	I DK 21 B-6	KR 509-9091		D 12 B 01/08	I R 12-702	186
			KR 732-01		D11 U31	I R 11-763	129
							208
							143

# LISTA CORRISPONDENZE

da codice RNB

AIRTECH	RNB	CF / PIRELLI		CONTITECH	FIRESTONE	
32926 K	<b>A520132C</b>	I T 19 E-2L	206333			
34157 KP	<b>A520133C</b>			4157 NP 04	IT 15 MPW-7	W01 M58 6297
36200 K	<b>A520139C</b>					
36199 K	<b>A520140C</b>					
382430 K	<b>A520142C</b>					
382520 K	<b>A520143C</b>					
361421 K	<b>A520144C</b>					
361481 K	<b>A520145C</b>					
32918 K	<b>A520146C</b>	I T 19 E-1	205456	4810 NP 05	IT 19 L-7	W01 M58 6338
30076 K	<b>A520147C</b>	I T 19 E-6	201715			
361480 K	<b>A520148C</b>					
361420 K	<b>A520149C</b>					
3936	<b>A520150</b>			936 N		
320270	<b>A520151</b>	I S 270-20V	202773			
323290	<b>A520152</b>	I S 290-23V	204427			
320285	<b>A520153</b>	I S 285-20	96534			
3819	<b>A520154</b>	I S 215-22	90609	819 N		
3819	<b>A520154</b>	I S 215-23	202189	819 N		
36884K	<b>A520162C</b>	I T 19 E-1	96884			
36885K	<b>A520163C</b>	I T 19 E-2	96885			
34420 K	<b>A520164C</b>	I T 19 E-2	204420			
38186KPP	<b>A520165C</b>			4157 NP 06	IT 15 MPW-7	W01 968 8186
374521 K	<b>A520166C</b>					
362421 K	<b>A520167C</b>					
391210-01K	<b>A520168C</b>					
3813-03 K	<b>A520169C</b>					
	<b>A520170C</b>					
	<b>A520172C</b>					
39780 K	<b>A520173C</b>					
34156-03 K	<b>A520173C</b>				IT 15 M-6	W01 379 9089
3811-02 K	<b>A520174C</b>					
36416 K	<b>A520175C</b>					
3809 T		I T 320 SP	89753	809 NTB	IT 15 L-6	W01 M58 0687
34810 T		I T 19 E-1	93702	810 NTB	IT 19 L-7	W01 M58 0749
3921		I S 285-23	202728	921 N	IRIA 415-260	W01 095 0226
391324 K		I T 19 E-2	203878	811 MB3	IT 19 F-11	W01 M58 6359/ 6334
34390-02 P				4390 NP 02		
3706				706 N		
3746				746 N		
3788				788 N		
3873				873 N		
31720				1720 N		
31774				1774 N		
31924				1924 NI		
39001						
30081 K					IT 17 B11	W01 M58 8747
30081-01 K					IT 15VLT-10.5	W01 358 9580
30743 K						
32145 K						
32618 K						
34022-01 K						
34022-01 P						
34023 P		I T 19 E-2		4023 N	IT 19 L-11	W01 M58 6335
34028 P				4028 N		
34150 T				4150 NP 01	IT 15 M-0	
3415-25 2L						
3415-28 2L						
34154-02 K					IT 15 M-4	W01 358 9010
34154-03 K					IT 15 M-4	W01 D08 9056

# LISTA CORRISPONDENZE

da codice RNB



GART	PHOENIX	TAURUS	DUNLOP UK	SPRINGRIDE	GOODYEAR	Pag.
					I R 14-728	145
	I DK 20 A-I	KR 915-52				176
						223
						222
D278/E (2.430)						244
D278/F (2.520)						245
D276/R (1.421)						239
D276/LR (1.481)						241
D277/B (4.423)					I R 14-730	144
D287/D (2.670)						137
D276/LR (1.480)						240
D276/R (1.420)						238
			PNP 309070100	D12S01		66
D290E (0.340)						77
						79
D276/E (0.330)						78
D296/C (0.360)						53
D296/C (0.360)						53
D277/B (2.421)						225
D277 (2.503)						226
						194
	I DK 20 A-I					228
D277/DA (4.521)						243
D276/R-2F (2.421)						242
D278/H (4.512)						250
D277/D (4.520)						
D277/DA (4.523)						
						237
		KR 506-28			D12B16	I R 12-706
D287 (4.522)						169
						99
						I R 14- 704
	I D 23 C-I	UR 504-13				224
						I R 12-709
						91
						I R 14-713
D276/BS (0.391)	I E 17	B 160			D10S04	202
					8043	63
					D 13 B24	I R 11-703
						259
						192
						36
						45
		B 155				52
						55
						73
						74
						76
						229
						I R 13-150
						138
						I R 13-118
						139
						140
						141
						142
						153
						152
						154
						156
						I R 12 - 097
						157
						82
						83
						159
						160

# LISTA CORRISPONDENZE

da codice RNB

AIRTECH	RNB	CF / PIRELLI	CONTITECH	FIRESTONE	
34154-04 K				IT 15 M-4	W01 S05 7283
34154-05 K				IT 15 M-4	W01 358 9069
34156 T					
34156-01 K				IT 15 M-6	W01 358 8929
34156-02 K				IT 15 M-6	W01 M58 9229
34156-02 P			4156 NP 05	IT 15 M-6	w01 352 0712
34156-05 K				IT 15 M-6	W01 358 9082
34156-07 K				IT 15 M-6	W01 358 8929
34156-08 K				IT 15 M-6	W01 358 9361
34156-09 K				IT 15 M-6	W01 358 9096
34156-10 K				IT 15 M-6	W01 379 9207
34156-11 K				IT 15 M-6	W01 F79 7349
34158 P			4158 NP 02	IT 15 MPW-7	
34159 K		IT 323-40	4159 NP 05	IT 15 M-9	
34159-03 K				IT 15 M-9	
34159-03 P					
34159-04 K				IT 15 M-9	W01 M58 9222
34159-07 K					
34159-08 K				IT 15 M-9	W01 358 9192
34159-09 K				IT 15 M-9	W01 358 9104
34737-01 K			4737 NP 01		
34737-02 K			4737 NP 02		
34757-01 K			4757 NP 01		
34757-02 K			4757 NP 02		
34813 P		IT 19 E-2 BR	4813 NP 07	IT 19 L-11	
3638-06 K			836 MBK6		
3725 K			725 NP 02	IT 66 E-10.8	W01 M58 8969
37803 P					
3808 T			808 NT		
3810 P			810	IT 15 L-7	W01 M58 0491 / 0749
3811 P		IT 19 E-2	811 MI6	IT 19 F-11	W01 M58 6333
3811-01 K			811 MB		
3811-01 P			811 MB	IT 19 F-11	
3811-02 P			811	IT 19 L-11	W01 M58 6359
3811-03 P			811 MB3	IT 19 F-11	
3811-04 P					
3811-05 P					
3811-06 K			811 MB		W01 M58 6359
3811-06 P			811 MB3	IT 19 F-11	W01 M58 6334
3811-07 K			810 MI6 KI	IT 19 F-11	
3813-01 K			813 MB		
3813-01 P			813 MB		
3813-05 K				IT 19 L-11	W01 358 9122
3813-06 K			813 MB		
3836-04 K			836 MBK4		
3836-07 K			836 MK7	IT 17AR-4,5	D08 8715
3897 K					
39001 K		IT C 300-38			
39002-A3			4157 NP 05	IT 15 MPW-7	W01 M58 7074
39002-A8			4157 NP 04	IT 15 MPW7	W01 M58 6297
3909 T		IT 19 E-4	909 NT	IT 15 L-6	W01 M58 0031
3912 K			912 MB	IT 19 L-14	W01 M58 7385
391208 K				IT 15 M-9	W01 M58 8859 / 3799091
391305 K					
3944 K			944 N		



# LISTA CORRISPONDENZE

da codice RNB



	GART	PHOENIX	TAURUS	DUNLOP UK	SPRINGRIDE	GOODYEAR	Pag.
							161
						I R 12-069	162
							163
							166
							168
		I DK 21 A-2					167
						I R 12-092	170
						I R 12-461	171
						I R 12-716	172
							173
							174
							175
							177
	D278/H	I DK 21 B5-B2	K-509-22		D12B08	I R 12-701	180
							184
				PNP 311370000	D12B08		183
							185
						I R 12-103	187
						I R 12-167	188
							189
							198
							199
							200
							201
	D287 (4.520)	I D 28 B-9	KR 622-01		D13B10	I R 14-727	203
							0
		I DF 32	UR 836- 11			I R 14-747	88
							227
		I D 23 A-1	UR 500-13				90
		I D 28 A		PNP 307320000			92
					SP 2066	I R 14-718	94
							97
			K 622-26 SM	PNP 311670000		I R 14-719	96
			KR 622-31				98
							100
							101
							102
							104
							103
					D13B24	I R 14-719	105
							109
					D13 U32		108
							111
							112
			KR 721-01		D 13 B33	I R 12-723	118
							120
							124
		I DK 21 A3			D 12 B17	I R 11-106	230
		I DK 21 A8/4			D 12 B18	I R 11-111	231
		I D23 B2					234
			B 151				234
					D13 B14		125
			KR 509-9091		D12B08/01		126
					D 13 B05		246
							253
							135

# LISTA CORRISPONDENZE

da codice AIRTECH

AIRTECH	RNB	CF / PIRELLI		CONTITECH	FIRESTONE	
3644	A520002	I S 285-24	92574	644 N	IRIA 390-295	W01 095 0118
3661	A520009	I S 310-28	91016	661 N	IRIC 390-310	W01 095 0021
3662	A520046	I SC 360-30	92594	662 N	IRID 355-355	W01 095 0207/0030
3673	A520042			673 N		
3701	A520122			701 N	IR3M 340-340	W01 095 0205
3706				706 N		
3713	A520064			713 N		
3715	A520082	I SC 310-16	93518	715 N	IRIC 335-310	W01 095 0087
3716	A520076	I SC 300-34	92548	716 N	IR2A 450-305	W01 095 0145
3719	A520083	I SC 360-43	92593	719 N	IR2D 530-360	W01 095 0192
3720	A520044	I SC 290-30	88802	720 N	IR2A 460-295	W01 095 0195
3727	A520084	I SC 360-34	92575	727 N	IR2D 460-360	W01 095 0191
3728	A520085	I SC 360-34	92575	728 N	IR2D 470-360	W01 095 0419
3737	A520027	I S 323-23	89756	737 N	IR2A 480-330	W01 095 0211
3746				746 N		
3757	A520077			757 N	IR2A 380-305	W01 095 0212
3762	A520048	I SC 360-30	92594	762 N	IR2D 390-360	W01 095 0190
3768	A520043			768 N	IR2A 370-285	W01 095 0198
3769	A520099			769 N	IRIA 380-260	W01 095 0204
3782	A520065	I S 270-25 C	97608	782 N	IRIA 415-285	W01 095 0197
3786	A520038			786 N		
3788				788 N		
3819	A520154	I S 215-22	90609	819 N		
3819	A520154	I S 215-23	202189	819 N		
3838	A520111			838 N		
3873				873 N		
3876	A520101	I S 323-34	92477	876 N		
3882	A520039	I SC 250-28	97042	882 NI		
3883	A520096			883 NI		
3884	A520086	I SC 270-28	97043	884 N		
3896	A520118			896 N	IRIJ 520-285 FF	W01 095 0245
3897	A520032	I S 320 30	88788	897 N	IRIK 440-320 FF	W01 095 0229
3916	A520097			916 NI		
3921		I S 285-23	202728	921 N	IRIA 415-260	W01 095 0226
3927	A520033			927 N	IR IK 380 280	W01 095 0244
3928	A520078			928 N	IRIK 380-320 FF	W01 095 0228
3936	A520150			936 N		
3943	A520026	I S 285-18	88809	943 N	IRIA 260-285	W01 095 0189
3944	A520035	I S 270-23	97619	944 N	IRIA 390-270	W01 095 0121
3945	A520003	I S 285-25 C	97555	945 N	IRIA 460-290	W01 095 0063
31234	A520116			1234 N		
31277	A520124				IR4U 395260	W01 095 0453
31421	A520092			1421 N		
31720				1720 N		
31774				1774 N		
31885	A520031			1885 NI	IR2A445 280	W01 095 0429
31924				1924 NI		
34940	A520053			4940 NP 02		
34941	A520054			4941 NP 02		
34960	A520047			4960 NP 02		
34961	A520071			4961 NP 02		
39001						
320270	A520151	I S 270-20V	202773			
320285	A520153	I S 285-20	96534			
323290	A520152	I S 290-23V	204427			
30076 K	A520147C	I T 19 E-6	201715			
30081 K					I T 17 B11	W01 M58 8747
30081-01 K					I T 15VLT-10.5	W01 358 9580

# LISTA CORRISPONDENZE

da codice AIRTECH



	GART	PHOENIX	TAURUS	DUNLOP UK	SPRINGRIDE	GOODYEAR	Pag.
	D276/B (0.390)	I E 21	B 121	PNP 301470101	D11S01	8017	31
	D 297 (0.390)	I E 25	B 114	PNP 304980101	D12S02	8018	32
		I E 32	B 143	PNP 302730101		9007	33
		I F 21 A	B 141				34
		I E 26-I	B 116-I			9006	35
							36
							37
		I F 25	B 144	PNP 304890101		8015	38
		I F 26 B-I	B 197				39
		I F 32 B-I	B 153	PNP 304620101		8118	40
		I F 21	B 152	PNP 301000100	D12S04	9008	41
		I F 32 A	B 149	PNP 306420100		8117	42
		I F 32 A-2	B 149	PNP 306420100		8117	43
		I F 26	B 127				44
							45
		I F 26 C	B 126				46
		I F 32	BL 143	PNP 307800100		9010	47
		I E 27	B 125				48
		I E 18	B 156	PNP 301470101	D10S02	8053	49
	D290 (0.420)	I E 21-D	B 124			9013	50
		I F 14	B 102				51
			B 155				52
	D296/C (0.360)						53
	D296/C (0.360)						53
		I F 26 D					54
							55
	D298/C (0.460)					8314	56
		I F 16	B 155				57
		I F 21 C2				9012	58
		I F 20 A	B 249			9002	59
		2 E 18 A	B 166	PNP 305140100		8040	60
	D278 (0.430)	2 E 23	B 165	PNP 305210101	SP 2192	8028	61
		I F 21 C-5	B 154		D12S05	9015	62
	D276/BS (0.391)	I E 17	B 160		D10S04	8043	63
		2 E 18 B	B 179	PNP 300080100		8037	64
		2 E 23 A	B 178	IC 3308	D12S03	8042	65
				PNP 309070100	D12S01		66
	D276/D (0.260)		B 194	PNP 316720100		9001	67
	D290/B (0.390)					8012	68
	D276 (0.420)	I E 21-C	B 124	PNP 301000101	D11S02	9014	69
							70
				PNP 31095			71
							72
							73
							74
		I F 20 B-I				9003	75
							76
							217
							218
							220
							221
							229
							77
	D290E (0.340)						78
	D276/E (0.330)						79
							137
	D287/D (2.670)						138
						I R 13-150	138
						I R 13-118	139

# LISTA CORRISPONDENZE

da codice AIRTECH

AIRTECH	RNB	CF / PIRELLI		CONTITECH	FIRESTONE	
30743 K						
32145 K						
32618 K						
32619 KPP	A520131C	I T 300-37	206585		IT 17 BS-6	W01 M58 8612
32918 K	A520146C	I T 19 E-1	205456	4810 NP 05	IT 19 L-7	W01 M58 6338
32926 K	A520132C	I T 19 E-2L	206333			
34004 K	A520062C	I T 323-33	97722	4004 NP 03	IT 17 BS-6	W01 M58 6366
34004 KPP	A520090C	I T 300-37	203715	4004 NP 03	I T 17 BS6	W01 M58 6366
34004 P	A520062	I T 300-37		4004 NP 02	IT 17 BS-6	
34022 K	A520055C			4022 NP 03	IT 17 BS-6	W01 M58 6367
34022 KPP	A520095C	I T 300-37	206340	4022 NP 03	I T 17 BS6	W01 M58 6366
34022 P	A520055			4022 NP 02	IT 17 BS-6	W01 M58 0756
34022-01 K						
34022-01 P						
34023 K	A520059C	I T 19 E-2	204676	4023 NP 03	IT 19 L-11	W01 M58 6348
34023 P		I T 19 E-2		4023 N	IT 19 L-11	W01 M58 6335
34028 P				4028 N		
34150 T				4150 NP 01	IT 15 M-0	
3415-25	A520050	I S 280-25	203000	RZ 415-25	IR5P 345-290	W01 095 0381
3415-25 2L						
3415-28	A520051	I S 280-28	203001	RZ 415-28	IR5P 410-290	W01 095 0382
3415-28 2L						
34154 KPP	A520057C			4154 NP 05		
34154-02 K					I T 15 M-4	W01 358 9010
34154-03 K					I T 15 M-4	W01 D08 9056
34154-04 K					I T 15 M-4	W01 S05 7283
34154-05 K					I T 15 M-4	W01 358 9069
34156 KPP	A520089C	I T 323-32	97306	4156 NP 06	IT 15 M-6	W01 358 9361
34156 P	A520080	I T 323-32		4156 NP 01	IT 15 M-6	
34156 T						
34156-01 K					IT 15 M-6	W01 358 8929
34156-02 K					IT 15 M-6	W01 M58 9229
34156-02 P				4156 NP 05	IT 15 M-6	w01 352 0712
34156-03 K	A520173C				IT 15 M-6	W01 379 9089
34156-05 K					I T 15 M-6	W01 358 9082
34156-07 K					I T 15 M-6	W01 358 8929
34156-08 K					I T 15 M-6	W01 358 9361
34156-09 K					I T 15 M-6	W01 358 9096
34156-10 K					I T 15 M-6	W01 379 9207
34156-11 K					I T 15 M-6	W01 F79 7349
34157 KP	A520133C			4157 NP 04	IT 15 MPW-7	W01 M58 6297
34158- KPP	A520091C			4158 NP 03	I T15 MPW9	W01 M58 8185
34158 P				4158 NP 02	I T15 MPW-7	
34159 K		I T 323-40		4159 NP 05	IT 15 M-9	
34159 P	A520117	I T 323-40		4159 NP 05	IT 15 M-9	
34159-02 K	A520066C	I T 323-40	204124	4159 NP 06	IT 15 M-9	W01 M58 9130
34159-02 KPP	A520094C	I T 323-40	200751	4159 NP 06	IT 15 M-9	W01 379 9131
34159-03 K					IT 15 M-9	
34159-03 P						
34159-04 K					IT 15 M-9	W01 M58 9222
34159-05 K	A520128C	I T 323-40	202302	4159 NP 07	I T15 M-9	W01 M58 358 9191
34159-07 K						
34159-08 K					I T15 M-9	W01 358 9192
34159-09 K					I T15 M-9	W01 358 9104
34390-01 K	A520093C			4390 NP 01		
34390-01 P	A520093	I VSC 285-30	206782	4390 NI		
34390-02 K	A520098C			4390 NP 02		
34390-02 P				4390 NP 02		

# LISTA CORRISPONDENZE

da codice AIRTECH



GART	PHOENIX	TAURUS	DUNLOP UK	SPRINGRIDE	GOODYEAR	Pag.
						140
						141
						142
						143
D277/B (4.423)					I R 14-730	144
					I R 14-728	145
	I DK 22 E-5	K 505-27SM		D12B13	I R 11-706	147
	I DK 22 E-8			D12B13	I R 11-713	148
					I R 11-705	118
		KR 725-28		D13B25	I R 11-710	150
	I DK 22 E-9			D12B14	I R 11-714	151
					I R 11-709	149
						152
D277 (4.505)	I D 28 B-10			D13B26	I R 14-729	155
						154
						156
					I R 12 - 097	157
	2 G 20	B 271			9004	80
						82
	2 G 20 A	B 272			9005	81
						83
						158
						159
						160
						161
D 278/G (4.421)	I DK 21 A-2	KR 50-28		D12B16	I R 12-069	162
					I R 12-716	165
						164
						163
						166
						168
	I DK 21 A-2					167
		KR 506-28		D12B16	I R 12-706	169
					I R 12-092	170
					I R 12-461	171
					I R 12-716	172
						173
						174
						175
	I DK 20 A-1	KR 915-52				176
D278HS (1.530)	I DK 20 B-1				I R 12-749	178
						177
D278/H	I DK 21 B5-B2	K-509-22		D12B08	I R 12-701	180
					I R 12-761	179
D278/H (4.511)	I DK 21 B-2	KR-509-25	PNP311370000	D12B02	I R 12-701	181
D278/H (1.510)	I DK 21 B8	KR-509-25	PNP311370000	D12B02	I R 12-721	182
						184
			PNP 311370000	D12B08		183
						185
D278/H (2.511)	I DK 21 B-6	KR 509-9091		D 12 B 01/08	I R 12-702	186
					I R 12-103	187
					I R 12-167	188
						189
						191
						190
						193
						192

# LISTA CORRISPONDENZE

da codice AIRTECH

AIRTECH	RNB	CF / PIRELLI		CONTITECH	FIRESTONE	
34420 K	A520164C	I T 19 E-2	204420			
3450-25	A520052	I S 300-27	203386	RZ 450-25		
34713 K	A520072C			4713 NP 02		
34713 P	A520072			4713 N		
34718 K	A520121C			4718 N		
34737-01 K				4737 NP 01		
34737-02 K				4737 NP 02		
34757-01 K				4757 NP 01		
34757-02 K				4757 NP 02		
34810 T		I T 19 E-1	93702	810 NTB	IT 19 L-7	W01 M58 0749
34813 K	A520056C	I T 19 E-2 BR	97764	4813 N P07	IT 19 L-11	W01 S05 7358
34813 P		I T 19 E-2 BR		4813 NP 07	IT 19 L-11	
34838 P	A520126			4838 NP 03		
34881 P	A520030	I TC 360-40	205537		IT 66D-7.0	W01 M58 8601
34881-01 K	A520030C	I TC 360-45		4881 MB	IT 66D-7.0	W01 M58 8601
34881-01 KPP	A520130C					
34911 K	A520075C			4911 NP 02		
34911 P	A520075			4911 N		
34912 K	A520060C	I T 19 E-4	206779	4912 NP 07		
34912 P	A520060	I T 19 E-4	206780	4912 NP 08		
34913 K	A520045C	I T 19 E-93	206201	4913 NP 02	IT 19 F-14	W01 095 0366
34913 P	A520045	I T 19 E-93	206201	4913 NP 02	IT 19 F-14	W01 095 0366
34915 P	A520112			4915 NP 03		
34925 K	A520120C			4925 N		
34941 K	A520054C			4941 NP 02		
361420 K	A520149C					
361421 K	A520144C					
361480 K	A520148C					
361481 K	A520145C					
36199 K	A520140C					
36200 K	A520139C					
362421 K	A520167C					
3638-06 K				836 MBK6		
36416 K	A520175C					
36884K	A520162C	I T 19 E-1	96884			
36885K	A520163C	I T 19 E-2	96885			
3725 K				725 NP 02	IT 66 E-10.8	W01 M58 8969
3725 P	A520067	I TCS 360-45	202964	725 NP 01	IT 66 E-10.8	W01 M58 8969
3725-01 K	A520125C			725 NP 03		
374521 K	A520166C					
37803 P						
3808 T				808 NT		
3809 T		I T 320 SP	89753	809 NTB	IT 15 L-6	W01 M58 0687
3810 K	A520010C	I T 19 E-1	87413/1	810 MB	IT 19 L-7	W01 M58 6345/ 8775
3810 P				810	IT 15 L-7	W01 M58 0491/ 0749
3811 K	A520081C	I T 19 E-2	203878	811 MB	IT 19 F-11	W01 M58 6334
3811 P		I T 19 E-2		811 M16	IT 19 F-11	W01 M58 6333
3811-01 K				811 MB		
3811-01 P				811 MB	IT 19 F-11	
3811-02 K	A520174C					
3811-02 P				811	IT 19 L-11	
3811-03 P				811 MB3	IT 19 F-11	W01 M58 6359
3811-04 P						
3811-05 P						
3811-06 K				811 MB		
3811-06 P				811 MB3	IT 19 F-11	W01 M58 6359
3811-07 K				810 M16 K1	IT 19 F-11	W01 M58 6334
3813 K	A520070C	I T 19 E-2	87408	813 MB	IT 19 F-11	W01 M58 6364

# LISTA CORRISPONDENZE

da codice AIRTECH



GART	PHOENIX	TAURUS	DUNLOP UK	SPRINGRIDE	GOODYEAR	Pag.
						194
	I E 23	B 128				84
					I R 12 -762	196
						195
						197
						198
						199
						200
						201
					I R 14-713	202
D287 (4.520)	I D 28 B-9	KR 622-01		D13B10	I R 14-727	204
D287 (4.520)	I D 28 B-9	KR 622-01		D13B10	I R 14-727	203
						205
C292/A (0.461)	I DK 32 K					206
C292/A (2.460)	I DK 32 K	UR 837 01		D14U37/D14B37	I R 14-701	207
						208
						210
						209
					I R 13-711	212
						211
C282/H (1.600)	I D 28 HI6	KR 625-16			I R 14-753	214
						213
						215
						216
						218
D276/R (1.420)						238
D276/R (1.421)						239
D276/LR (1.480)						240
D276/LR (1.481)						241
						222
						223
D276/R-2F (2.421)						242
						0
					I R 14- 704	224
D277/B (2.421)						225
D277 (2.503)						226
	I DF 32	UR 836- 11			I R 14-747	88
C292-S (0.533)	I DF 32	UR 836- 11		D14 U38	I R 14-704	87
						89
D277/DA (4.521)						243
						227
	I D 23 A-1	UR 500-13				90
	I D 23 C-1	UR 504-13			I R 12-709	91
D277/B (4.420)	I D 28 A-2	k 621 26	PNP 311670000	D 13 B20	I R 14-716	93
	I D 28 A		PNP 307320000			92
D277 (4.506)	I D 28 B-7	KR 622-31		D 13 B17	I R 14-718	95
				SP 2066	I R 14-718	94
						97
		K 622-26 SM	PNP 311670000		I R 14-719	96
D287 (4.522)		KR 622-31				99
						98
						100
						101
						102
						104
						103
				D13B24	I R 14-719	105
D277 (4.500)	I D 28 B-2 E2	KR 622-26	PNP 31156/78	D 13 B19	I R 14-705	107

# LISTA CORRISPONDENZE

da codice AIRTECH

AIRTECH	RNB	CF / PIRELLI		CONTITECH	FIRESTONE	
3813 P	A520070			813 MB 0	IT 19 L-11	
3813-01 K				813 MB		
3813-01 P				813 MB		
3813-03 K	A520169C					
3813-05 K					IT 19 L-11	W01 358 9122
3813-06 K				813 MB		
38186KPP	A520165C			4157 NP 06	IT 15 MPW-7	W01 968 8186
382430 K	A520142C					
382520 K	A520143C					
3836 K	A520061C			836 MK I		
3836 P	A520061			836 M		
3836-01 P	A520041			836 MB	IT-17 AR4,5	W01 D08 0776
3836-02 K	A520069C			836 M2 K I	IT-17 AR4,5	
3836-02 P	A520040			836 M2	IT-17 AR4,5	W01 D08 0777
3836-04 K				836 MBK4		
3836-07 K				836 MK7	IT 17AR-4,5	D08 8715
3881 P	A520029	I TC 360-45	204530	881 MB	IT 66 D-10.8	W01 M58 8978
3881-01 K	A520029C	I TC 360-45	205800	881 MB	IT 66 D-10.8	W01 M58 8978/8966
3881-01 KPP	A520087C	I TC 360-45	206357	881 MB	IT 66 D-10.8	W01 M58 8978/8966
3897 K						
39001 K						
39002-A3		I TC 300-38		4157 NP 05	IT 15 MPW-7	W01 M58 7074
39002-A3 K	A520036C	I TC 300-38	205598	4157 NP 05	IT 15 MPW-7	W01 M58 7074
39002-A3-01 K	A520127C				IT 15MPW-7	W01 379 6315
39002-A8				4157 NP 04	IT 15 MPW7	W01 M58 6297
39002-A8 KPP	A520037C	I T 300-40		4158 NP 04	IT 15 MPW7	W01 M58 6297
3909 T				909 NT	IT 15 L-6	W01 M58 0031
3912 K		I T 19 E-4		912 MB	IT 19 L-14	W01 M58 7385
391208 K	A520024C				IT 15 M-9	W01 M58 8859/ 9091
391208 K					IT 15 M-9	W01 M58 8859 / 3799091
391209 K	A520023C	I T 323-40	96871		IT 15 M-9	W01 M58 6289
391210 K	A520006C	I T 323-40	96864			
391210 K/I	A520006C/I	I T 323-40 BG	97307			
391210-01K	A520168C					
391303 K	A520012C	IT 19 E-3	97393		IT 19 L-12	W01 M58 7380/ 8765
391304 K	A520019C	IT 19 E-3	201840		IT 19 L-14	W01 M58 8762
391305 K						
391314 K	A520020C			912 MB	IT 19 L-14	W01 M58 7385/ 8766
391318 K	A520021C	I T 19 E-2	204371	811 MB	IT 19 L-11	W01 M58 6361
391318 K/I	A520021C/I	I T 19 E-2	97730			
391320 K	A520049C	I T 19 E-1	87413/1	810 MB	IT 19 L-7	W01 M58 6345/ 7337
391323 K	A520074C					
391324 K		I T 19 E-2	203878	811 MB3	IT 19 F-11	W01 M58 6359/ 6334
3940 K	A520034C			940 MB	IT 17D-6.5	
3940 KPP	A520129C			940 MB		
3940 P	A520034	I TC 300-30	205536	940 MB	IT 17D-13	W01 M58 8613
3941 K	A520028C	I TC 300-36	205170	941 MB	IT 17D-8.3	W01 M58 8620/8619
3941 KPP	A520088C	I TC 300-36	206356	941 MB	IT 17 D-8.3	W01 M58 8620/8619
3941 P	A520028	I TC 300-36	204466	941 MB	IT 17 D-8.3	W01 M58 8620/8619
3942 P	A520068			942 MB		
3942-01 K	A520068C			942 MB		
3944 K				944 N		
3951 P	A520063			951 MB	IT 17 D-11.8	W01 M58 8621
39780 K	A520172C					
	A520170C					



# LISTA CORRISPONDENZE

da codice AIRTECH



GART	PHOENIX	TAURUS	DUNLOP UK	SPRINGRIDE	GOODYEAR	Pag.
						106
						109
				D13 U32		108
D277/D (4.520)						110
						111
						112
	I DK 20 A-1					228
D278/E (2.430)						244
D278/F (2.520)						245
	I DF 25 11	KR 721-06		D13 B32	I R 12-712	114
	I DF 25 1	KR 721		D 13 U32	I R 12-700	113
	I DF 25 1	721-01		D 13 U32	I R 12-700	115
	I DF 25 13	KR 721-03		D13 B31	I R 12-710	117
	I DF 25 3			D13 U31	I R 12-710	116
						118
		KR 721-01		D 13 B33	I R 12-723	120
C292 (0.531)	IDK 32-1	KR 836-01		D14 U36	I R 14-708	121
C292 (2.531)	IDK 32-1	UR 836-01		D14 B36	I R 14-703	122
C292 (2.530)		KR 836-01		D14 B36	I R 14-703	123
						124
						230
	I DK 21 A3			D 12 B17	I R 11-106	231
C294 (2.450)	I DK 21 A3	KR 915-54		D 12 B17	I R 11-106	232
		KR 915-51				233
	I DK 21 A8/4			D 12 B18	I R 11-111	234
C294 (2.451)	I DK 21 A8/4			D 12 B18	I R 11-111	235
	I D23 B2	B 151				125
						126
		KR 509-9091		D13 B14		246
		KR 509-9091		D 12 B07/09		246
D278/H (2.512)				D12B08/01		246
D278/H (4.514)				D 12 B18		247
				D 13B06/10		248
						249
D278/H (4.512)						250
D287/B (4.580)	I D 28 HI3			D 13 B 03		251
				D13 B04		252
				D 13 B05		253
				D 13 B14		254
D277/2F(2.500)	I D 28 D-2	K 622-26 SM	PNP 311670000	D13B18/12	I R 14-706	255
D277/2F(2.504)						256
D277/B (4.420)		B 104/K 104	PNP 311780000	D13B01/20	I R 14-059	257
				D 13 B23		258
				D 13 B24	I R 11-703	259
C293/A (0.411)	I DK 21 K	UR 732-01		D11 U31	I R 11-763	128
		KR 732-01		D11 U31	I R 11-763	129
C293/A (0.411)	I DK 21 K	KR 732-01		D11 U31	I R 11-703	127
C293 (2.510)	I DK 21	UR 730-01		D11 B32	I R 11-702	131
		KR 730-01		D11 U30		132
C293 (0.511)	I DK 21	KR 730-01		D11 U30	I R 11-700	130
		UR 837-01			I R 14-700	133
	BPW 35-1	UR 837-01				134
						135
					I R 11-704	136
						237
D277/DA (4.523)						

# LISTA CORRISPONDENZE

## MOLLE AD ARIA A LOBI

da codice PIRELLI

AIRTECH	RNB	CF / PIRELLI	CONTITECH	FIRESTONE
2B-370-Hyd / 113361	A520137	<b>21BR 89457</b>		
3B-300Hyd / 115005	A520136	<b>322BR 89413</b>		
2B-220-3 / 113002	A520106	<b>T20 86660</b>	895 N	W01.M58-7894
2B-220 / 113001	A520079		FD 200-19 MB	W01.M58-6887/6910
3B-300 / 115004	A520107			
3B-300 / 115002	A520108			
2B-300 / 113300	A520109		FD 412-18	
2B-300 / 113301	A520110			
3B-300 / 115003	A520113		FT 412-32	
3B-400-Hyd / 115155	A520114			
2B-255 / 113100	A520119		FD 210-22	
2B-285 / 114250	A520123		608 N	
2B-300 / 114300	A520135			
2B-200 / 113060	A520141		FD 138-18	
220-60 / 111150	A520161			
	A520171C			

da codice RNB

2B-220 / 113001	<b>A520079</b>		FD 200-19 MB	W01.M58-6887/6910
2B-220-3 / 113002	<b>A520106</b>	T20 86660	895 N	W01.M58-7894
3B-300 / 115004	<b>A520107</b>			
3B-300 / 115002	<b>A520108</b>			
2B-300 / 113300	<b>A520109</b>		FD 412-18	
2B-300 / 113301	<b>A520110</b>			
3B-300 / 115003	<b>A520113</b>		FT 412-32	
3B-400-Hyd / 115155	<b>A520114</b>			
2B-255 / 113100	<b>A520119</b>		FD 210-22	
2B-285 / 114250	<b>A520123</b>		608 N	
2B-300 / 114300	<b>A520135</b>			
3B-300Hyd / 115005	<b>A520136</b>	322BR 89413		
2B-370-Hyd / 113361	<b>A520137</b>	21BR 89457		
2B-200 / 113060	<b>A520141</b>		FD 138-18	
220-60 / 111150	<b>A520161</b>			
	<b>A520171C</b>			

da codice AIRTECH

<b>220-60 / 111150</b>	A520161			
<b>2B-200 / 113060</b>	A520141		FD 138-18	
<b>2B-220 / 113001</b>	A520079		FD 200-19 MB	W01.M58-6887/6910
<b>2B-220-3 / 113002</b>	A520106	T20 86660	895 N	W01.M58-7894
<b>2B-255 / 113100</b>	A520119		FD 210-22	
<b>2B-285 / 114250</b>	A520123		608 N	
<b>2B-300 / 113300</b>	A520109		FD 412-18	
<b>2B-300 / 113301</b>	A520110			
<b>2B-300 / 114300</b>	A520135			
<b>2B-370-Hyd / 113361</b>	A520137	21BR 89457		
<b>3B-300 / 115002</b>	A520108			
<b>3B-300 / 115003</b>	A520113		FT 412-32	
<b>3B-300 / 115004</b>	A520107			
<b>3B-300Hyd / 115005</b>	A520136	322BR 89413		
<b>3B-400-Hyd / 115155</b>	A520114			
	A520171C			

# LISTA CORRISPONDENZE

## MOLLE AD ARIA A LOBI



### da codice PIRELLI

	GART	PHOENIX	TAURUS	DUNLOP UK	SPRINGRIDE	GOODYEAR	Pag.
	T274 274.2.210				SP 2599		272
	T271 271.3.293				SP 2597 RE		276
		2B 12R-3					266
	T291/2 (291.2.200)	2B 12R			9"1/4 SO 9201		265
					SP 2666		275
	T271/S 271.3.296						273
					SP 1541 NB		269
					SP 2665		270
				PNP 305 520 178	SP 1542		274
				PNP 313 170 100	SP 2141		277
					SP 1538		267
		2B 20R	F211-200				268
					SP 256 NB (VSM 10178)		271
					SP 1490		264
	T291 / B (291.1.170)						263
	T275 (275.1.120)						278

### da codice RNB

	T291/2 (291.2.200)	2B 12R			9"1/4 SO 9201		265
		2B 12R-3					266
					SP 2666		275
	T271/S 271.3.296						273
					SP 1541 NB		269
					SP 2665		270
				PNP 305 520 178	SP 1542		274
				PNP 313 170 100	SP 2141		277
					SP 1538		267
		2B 20R	F211-200				268
					SP 256 NB (VSM 10178)		271
	T271 271.3.293				SP 2597 RE		276
	T274 274.2.210				SP 2599		272
					SP 1490		264
	T291 / B (291.1.170)						263
	T275 (275.1.120)						278

### da codice AIRTECH

	T291 / B (291.1.170)				SP 1490		263
					SP 1490		264
	T291/2 (291.2.200)	2B 12R			9"1/4 SO 9201		265
		2B 12R-3					266
					SP 1538		267
		2B 20R	F211-200				268
					SP 1541 NB		269
					SP 2665		270
					SP 256 NB (VSM 10178)		271
	T274 274.2.210				SP 2599		272
	T271/S 271.3.296						273
				PNP 305 520 178	SP 1542		274
					SP 2666		275
	T271 271.3.293				SP 2597 RE		276
				PNP 313 170 100	SP 2141		277
	T275 (275.1.120)						278

## MOLLE AD ARIA PER SEDILI

da codice **PIRELLI**

AIRTECH	RNB	CF / PIRELLI	CONTITECH	FIRESTONE
125101	A520102		SZ 51-7	
125102	A520103		864 Z / SZ 60-6	
125103	A520104		SZ 62-7	
125104	A520105		865 Z / 937 N	
126001	A520138		SK 95-26	

da codice **RNB**

125101	<b>A520102</b>		SZ 51-7	
125102	<b>A520103</b>		864 Z / SZ 60-6	
125103	<b>A520104</b>		SZ 62-7	
125104	<b>A520105</b>		865 Z / 937 N	
126001	<b>A520138</b>		SK 95-26	

da codice **AIRTECH**

<b>125101</b>	A520102		SZ 51-7	
<b>125102</b>	A520103		864 Z / SZ 60-6	
<b>125103</b>	A520104		SZ 62-7	
<b>125104</b>	A520105		865 Z / 937 N	
<b>126001</b>	A520138		SK 95-26	

# LISTA CORRISPONDENZE

## MOLLE AD ARIA PER SEDILI



### da codice PIRELLI

	GART	PHOENIX	TAURUS	DUNLOP UK	SPRINGRIDE	GOODYEAR	Pag.
							281
							282
							283
							284
							285

### da codice RNB

							281
							282
							283
							284
							285

### da codice AIRTECH

							281
							282
							283
							284
							285





## CONDIZIONI GENERALI DI VENDITA

Tutte le ordinazioni da parte del Cliente sono subordinate alle presenti condizioni generali di vendita. Qualsiasi altra condizione inserita dal Cliente nell'ordine, verrà considerata di nessun valore, senza obbligo di avviso da parte nostra.

Per evitare errate interpretazioni degli ordini **si prega di usare sempre**, oltre alla descrizione del materiale desiderato, **il numero di codice del particolare**. Nei casi di discordanza tra il numero di codice e la parte descrittiva sarà ritenuto valido il numero di codice.

Gli ordini proposti potranno essere, insindacabilmente, non accettati e non potranno essere inferiori a € 600,00 IVA esclusa. L'accettazione degli ordini stessi si intende sempre **"salvo venduto"** anche se ciò sia esplicitamente espresso.

I termini di consegna eventualmente concordati hanno valore indicativo e non comportano una tassativa responsabilità e garanzia da parte nostra.

La merce viaggia a rischio e pericolo del Cliente, anche se resa franco destino. Il materiale inviato in ogni spedizione è sempre accompagnato da un "DOCUMENTO DI TRASPORTO" (DdT). **Poiché la firma da parte del vettore (all'atto dello svincolo) è liberatoria nei confronti del vettore stesso, si ricorda che eventuali discordanze o ammanchi devono essere fatti constatare al corriere al momento della consegna e denunciato con lettera al Corriere stesso e per conoscenza alla nostra Ditta.**

Non saranno accettate altre forme di pagamento se non quelle pattuite. In caso di inosservanza della sopraddetta condizione nonché del mancato pagamento, ci riserviamo il diritto di sospendere ed annullare le rimanenti consegne. L'acquirente sarà tenuto al risarcimento dei danni, al pagamento degli interessi vigenti e non potrà avanzare pretese di compensi od indennizzi per l'interruzione della fornitura. La merce rimarrà comunque di nostra proprietà fino al completo pagamento della stessa.

Eventuali reclami, di qualunque natura possano essere, devono pervenirci per iscritto entro 20 giorni data spedizione. Per eventuali difetti occulti tale termine è esteso a 90 giorni naturali consecutivi.

Se riconosciuti fondati, la nostra responsabilità si limita alla sostituzione del materiale contestato, pertanto non verranno riconosciuti addebiti per eventuali danni a cose, anche d'altri, o a persone.

La garanzia dei prodotti per vizi e difetti di qualsiasi natura ed entità ha la durata di un anno dalla data di produzione.

**Non si ricevono merci di ritorno senza nostra autorizzazione. I resi devono essere effettuati in porto franco. Se autorizzati in porto assegnato devono viaggiare solo con corrieri da noi indicati.** I particolari inviati come campioni dovranno eventualmente essere ritornati dal Cliente in **Porto Franco**. In caso contrario sarà addebitata la spesa di trasporto che abbiamo dovuto sostenere per il ritiro della merce.

Per eventuali contestazioni, qualunque siano le condizioni di pagamento e di consegna, l'Autorità Giudiziaria competente è quella di Bologna.

In caso di variazione di prezzo rispetto a quello indicato nel listino (per variazioni in più od in meno) il prezzo segnato in fattura sarà quello in vigore alla data della bolla di spedizione della merce qualunque sia la data di conferimento dell'ordine e della conferma dello stesso.

Non accettiamo nessuna responsabilità per eventuali errori o omissioni su questo catalogo. Ci riserviamo il diritto di apportare su questo catalogo qualsiasi modifica senza preavviso. E' vietata la riproduzione integrale e parziale del presente catalogo, senza autorizzazione scritta rilasciata dalla Nuti Roberto S.p.a.





Questo modulo, debitamente compilato, dovrà essere inviato a mezzo fax al numero 0542 671800

**Riferimenti impressi sulla molla ad aria**

Nome del costruttore :

Riferimento n<sub>i</sub> :

Altri riferimenti o nomi impressi sul pezzo :

Numero piatto superiore :

Numero pistone :

**Materiale del pistone :**

ALLUMINIO  ACCIAIO  COMPOSITO

**Filettatura pistone :**

METRICO  ALTRO

**La molla ha il tampone interno ?** S I  NO

**Dove ?** Piatto sup.  Piatto inf.  Pistone

**Vi preghiamo di disegnare sul piatto superiore e pistone le configurazioni richieste**

DIAMETRO MOLLA A=.....mm

ALTEZZA MOLLA B=.....mm

ALTEZZA PISTONE C=.....mm

DIAMETRO FORO SUPERIORE D=.....mm

DIAMETRO FORO INFERIORE E=.....mm

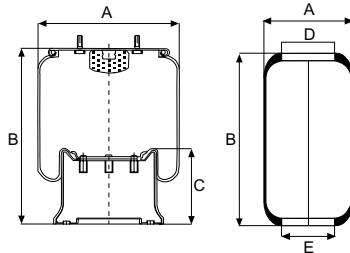

Piatto sup.

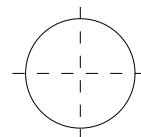

Perno o bullone ●

Entrata aria ⊗

Perno combinato ⊗

Pistone

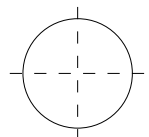

- 1) RIMORCHIO
- 2) AUTOCARRO
- 3) AUTOBUS/CORRIERA
- 4) ALTRO

- APPLICAZIONE STANDARD
- ASSALE SOLLEVABILE
- AGGIUNTA PER MODIFICA
- CABINA

1) Costruttore rimorchio : .....  
Costruttore sospensione : .....

2) Costruttore autocarro : .....  
Modello : .....  
Configurazione (es. 6x2 etc) : .....

3) Costruttore autobus : .....  
Modello : .....  
Costruttore telaio : .....

VOSTRA DITTA : .....

VOSTRO NOME : .....

NUMERO TEL. : ..... NUMERO FAX : .....

VOSTRO INDIRIZZO : .....







# AIRTECH®

Molle ad aria



**roberto nuti spa**

Distribuzione Roberto Nuti S.p.A.  
Via 1° Maggio, 7 (Z.I. Poggio Piccolo)  
40023 CASTEL GUELFO - Bologna - Italy  
TEL. +39 0542 671811 - FAX +39 0542 671800  
<http://www.rnb.it> - E-mail: [mail@rnb.it](mailto:mail@rnb.it)